

**PERMIT REVIEW CHECKLIST:**

PROJECT TYPE: CONTRACTOR STORAGE BAYS

OWNER: McGregor Interests  
ADDRESS: 11750 Stonegate Circle, Omaha, NE 68164  
PHONE & EMAIL: (402) 334-2123 geoff@mcgregorint.com

GENERAL CONTR.: To be determined following Bidding.  
ADDRESS:  
PHONE & EMAIL:

ARCHITECT: Paul J. Kelly, RA  
ADDRESS: 440 North 61st Street, Omaha, NE 68132  
PHONE & EMAIL: (402) 320-4131 pjka@architect@gmail.com

PROJECT ADDRESS: PIN 1729720452, Bennington, NE 68007  
USE: Contractor Storage Bays

GOVERNING CODES: International Building Code (2018 Edition)  
International Energy Code (IECC 2018 Edition)  
National Electrical Code (2023 Edition)  
Fire Codes per NE State Fire Marshal  
International Fire Code (2018 Edition)  
Nebraska Accessibility Guidelines  
International Mechanical Code (2012 Edition)  
Omaha Plumbing Code (2018 Edition)

OCCUPANCY: S-2 Warehouse  
ALLOWABLE AREA: 26,000 (per Table 506.2) Base Allowable Area.  
26,000 sf allowed > 10,000 sf proposed Building A area.  
26,000 sf allowed > 20,000 sf proposed Building B area.

OCCUPANT LOAD: 1,250 sf each Bay / 500 sf each = 3 Occupants at each Bay.  
3 Occupants x 0.2" each for width = 0.6" required width < 34" provided.  
Max 75' CPT per IBC 2018, Table 1006.2.1 if Occupant Load exceeds 30.  
Max 100' CPT allowed if Occupant Load is 30 or less.  
Max Travel Distance to the exit is 67' (See Bldg A Plan, Bay201).

ACCESSIBILITY: All entrances are at grade level.  
FIRE SPRINKLERS: Non-Sprinkled Building  
FIRE ALARM: Not required by IBC Chapter 9.  
EMERG. LIGHTING: To be provided per NEC  
EXITS PROVIDED: 1 Exit required from this tenant space per Table 1006.2.1.  
1 at each tenant area.  
NO. FLOORS: One

COMCheck: Attached for Envelope,  
See MEP Sheets for Interior & Exterior Lighting and Mechanical COMChecks.

ENVELOPE INSULATION REQUIREMENTS: (per 2018 IECC)  
ROOF: Metal Bldg Roof: R-19 + R-11 Liner System U-0.032 Max  
WALLS: Metal Bldg Walls: R-19 + R-6 ci U-0.031 Max  
FLOOR SLABS: Unheated: R-10 for 24" below grade  
DOORS: Non-Swinging (OH): U-0.19 Max  
Flush Swing Doors: U-0.61 Max  
FENESTRATION: Fixed Windows: U-0.36 Max  
Entry Doors: U-0.77 Max

**PERMIT REVIEW CHECKLIST (CONT.):**

ALLOWABLE AREAS: Type II-B Construction, Non-Sprinkled:  
23,000 (per Table 506.2) Base Allowable Area.  
23,000 sf allowed > 10,000 sf and 20,000 sf proposed building areas.  
MAX 5,000 SF FIRE AREAS for vehicle storage per IBC 903.2.10.

BUILDING A:  
CONSTRUCTION: Type II-B  
SQ. FOOTAGE: Total Building: 10,000 sf  
OCCUPANT LOAD: Total S-2 (Warehouse): 10,000 sf @ 500 sf (Gross) = 20 Occupants  
Each Bay: 1,250 sf = 2.5 each Bay = 3 Occupants (Exiting)

BUILDING B:  
CONSTRUCTION: Type II-B  
SQ. FOOTAGE: Total Building: 20,000 sf  
OCCUPANT LOAD: Total S-2 (Warehouse): 20,000 sf @ 500 sf (Gross) = 40 Occupants  
Each Bay: 1,250 sf = 2.5 each Bay = 3 Occupants (Exiting)

PLUMBING FIXT. REQ.: Per 2018 Omaha Plumbing Code  
S-2 Warehouse - 1,867 sf per occupant per Table 49-722(5A)  
1 Occupant per Bay.  
1 Water Closet and 1 Lavatory required at each Bay.  
< 25 Occupants does not require a DF

HISTORIC DESIGNATION: None  
HAZARDOUS MATERIAL: N/A  
PIN: 1729720452  
Legal Description: MCGREGOR BRAE LOT 2 BLOCK 0 LOT 2 2.243 AC

**PROJECT SCOPE NOTES:**

- PRE-ENGINEERED METAL BUILDING (PEMB) SHOP DRAWINGS SHALL BE SUBMITTED AT A LATER DATE AS A SEPARATE PERMIT APP.
- GENERAL CONSTRUCTION MATERIALS WILL BE STORED IN THE NEW BUILDING. THERE WILL BE NO HIGH-PILED STORAGE OR STORAGE OF VOLATILE CHEMICALS IN THE ADDITION. NO VEHICLE STORAGE WILL OCCUR AT THE ADDITION.
- THE FACILITY WILL NOT BE USED FOR THE STORAGE OF HAZARDOUS CHEMICALS AND IS NOT AN H OCCUPANCY.

GENERAL	
Sheet Number	Sheet Name
0.0	COVER SHEET

CIVIL	
Sheet Number	Sheet Name
1 OF 12	TOPOGRAPHIC SURVEY
2 OF 12	PAVING AND LAYOUT PLAN
3 OF 12	GEOMETRICS PLAN
4 OF 12	GRADING PLAN
5 OF 12	UTILITY PLAN
6 OF 12	GENERAL NOTES AND DETAILS
7 OF 12	STORMWATER POLLUTION PREVENTION PLAN
8 OF 12	SWPPP NOTES
9 OF 12	POST CONSTRUCTION STORMWATER MANAGEMENT PLAN
10 OF 12	POST CONSTRUCTION STORMWATER MANAGEMENT PLAN
11 OF 12	LANDSCAPE PLAN
12 OF 12	FIRE ACCESS AND COVERAGE PLAN

ARCHITECTURAL	
Sheet Number	Sheet Name
A1.A	BLDG A PLAN & DETAILS
A1.B	BLDG B PLAN & DETAILS
A2.A	BLDG A ELEV. & SECTIONS
A2.B	BLDG B ELEV. & SECTIONS

STRUCTURAL	
Sheet Number	Sheet Name
S101	FOUNDATION PLAN - BUILDING A
S102	FOUNDATION PLAN - BUILDING B
S300	GENERAL STRUCTURAL NOTES AND DETAILS
S301	SECTIONS AND DETAILS

MECHANICAL	
Sheet Number	Sheet Name
M0.0	MECHANICAL SYMBOLS
M0.1	MECHANICAL SPECS
M0.2	MECHANICAL COM CHECK
M1.1A	BUILDING A PLUMBING
M1.1B	BUILDING B PLUMBING
M6.1	PLUMBING DETAILS
M7.1	PLUMBING SCHEDULES
Grand total: 7	

ELECTRICAL	
Sheet Number	Sheet Name
E0.0	ELECTRICAL SYMBOLS
E0.1	ELECTRICAL SPECS
E0.2	ELECTRICAL SITE PLAN
E1.1A	BUILDING A ELECTRICAL
E1.1B	BUILDING B ELECTRICAL
E6.1	ELECTRICAL DETAILS AND DIAGRAMS
E7.1	ELECTRICAL SCHEDULES
Grand total: 7	

**COORDINATING PROFESSIONAL:**  
I, Paul J. Kelly, Nebraska Architectural License No. A-2608, am the Coordinating Professional for the Contractor Storage Bay Project at PIN 1729720452, Bennington, NE 68007.

10/30/2024



COVER SHEET	
REVISIONS	Date
No.	Description

**Contractor Storage Bays**  
McGregor Interests  
PIN 1729720452, Bennington, NE 68007

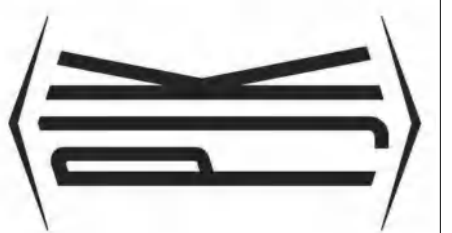

**Paul J. Kelly  
Architecture**  
440 North 61st Street  
Omaha, Nebraska 68132  
(402) 320 - 4131  
pjka@architecture.com

0.0

Project No: 24-021-01  
Date: 30 October 2024



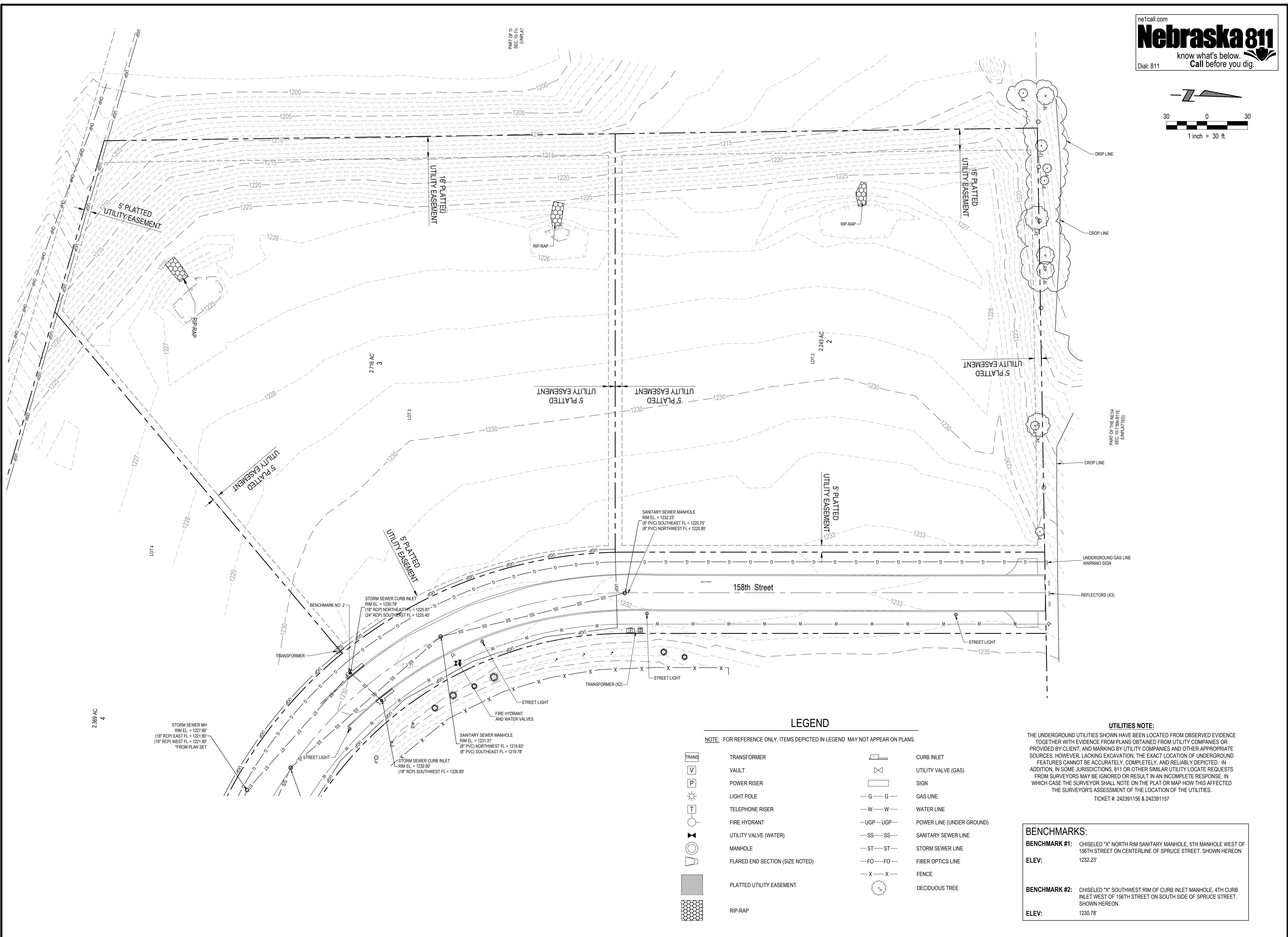
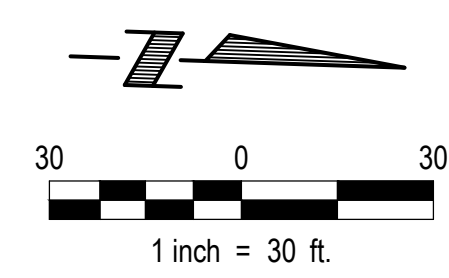

**LEGEND**

NOTE: FOR REFERENCE ONLY, ITEMS DEPICTED IN LEGEND MAY NOT APPEAR ON PLANS.

TRANS	TRANSFORMER	□	CURB INLET
V	VAULT	⊗	UTILITY VALVE (GAS)
P	POWER RISER	□	SIGN
☀	LIGHT POLE	-G-G-	GAS LINE
T	TELEPHONE RISER	-W-W-	WATER LINE
⊙	FIRE HYDRANT	-UGP-UGP-	POWER LINE (UNDER GROUND)
⊗	UTILITY VALVE (WATER)	-SS-SS-	SANITARY SEWER LINE
⊙	MANHOLE	-ST-ST-	STORM SEWER LINE
⊗	FLARED END SECTION (SIZE NOTED)	-FO-FO-	FIBER OPTICS LINE
□	PLATTED UTILITY EASEMENT	-X-X-	FENCE
⊙	RIP-RAP	⊙	DECIDUOUS TREE

**UTILITIES NOTE:**  
 THE UNDERGROUND UTILITIES SHOWN HAVE BEEN LOCATED FROM OBSERVED EVIDENCE TOGETHER WITH EVIDENCE FROM PLANS OBTAINED FROM UTILITY COMPANIES OR PROVIDED BY CLIENT, AND MARKING BY UTILITY COMPANIES AND OTHER APPROPRIATE SOURCES. HOWEVER, LACKING EXCAVATION, THE EXACT LOCATION OF UNDERGROUND FEATURES CANNOT BE ACCURATELY, COMPLETELY, AND RELIABLY DEPICTED. IN ADDITION, IN SOME JURISDICTIONS, 811 OR OTHER SIMILAR UTILITY LOCATE REQUESTS FROM SURVEYORS MAY BE IGNORED OR RESULT IN AN INCOMPLETE RESPONSE, IN WHICH CASE THE SURVEYOR SHALL NOTE ON THE PLAT OR MAP HOW THIS AFFECTED THE SURVEYOR'S ASSESSMENT OF THE LOCATION OF THE UTILITIES.  
 TICKET #: 242391156 & 242391157

**BENCHMARKS:**

**BENCHMARK #1:** CHISELED "X" NORTH RIM SANITARY MANHOLE, 5TH MANHOLE WEST OF 156TH STREET ON CENTERLINE OF SPRUCE STREET. SHOWN HEREON  
**ELEV:** 1232.23'

**BENCHMARK #2:** CHISELED "X" SOUTHWEST RIM OF CURB INLET MANHOLE, 4TH CURB INLET WEST OF 156TH STREET ON SOUTH SIDE OF SPRUCE STREET. SHOWN HEREON.  
**ELEV:** 1230.78'

**E & A CONSULTING GROUP, INC.**  
 Engineering • Planning • Environmental & Field Services  
 10806 Mill Valley Road, Suite 100 • Omaha, NE 68154  
 Phone: 402.895.4700 • Fax: 402.895.3599  
 www.eaeg.com  
 State of NE Certificate of Authorization #C-00008

**E & A CONSULTING GROUP, INC.**  
 Engineering Answers

**CONTRACTOR BAYS**  
 MCGREGOR BRAE - LOTS 2 & 3  
 BENVINGSTON, NEBRASKA

**TOPOGRAPHIC SURVEY**

**Preliminary**  
**Not For Construction**  
 10-5-2024

Revisions	Date	Description

Proj No: P2015.777.013  
 Date: 10/20/24 12:32 PM  
 Designed By: DCW  
 Drawn By: E&A  
 Scale: AS SHOWN  
 Sheet: 1 of 12  
 Joe Baratta



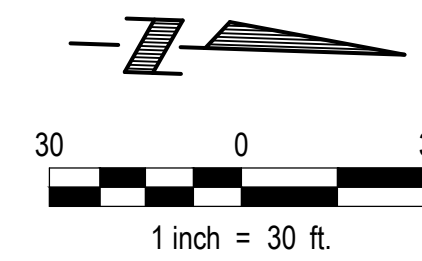

**LEGEND**

- Sawcut Full Depth and Remove Existing Pavement
- 6" PCC Pavement with Integral Curb
- Segmental Block Retaining Wall

**NO. BUILD NOTES**

- 1 Sawcut and Remove Pavement and Integral Curb as Required to Install Drive
- 2 7" PCC Pavement with Integral Curb, See Detail on Sheet 6
- 3 Drill and Install Tie Bars @ 4' On Center to Tie New Pavement to Existing Pavement. See Detail on Sheet 6
- 4 Van Accessible Handicap Sign and Post, See Detail on Sheet 6
- 5 Handicap Sign and Post, See Detail on Sheet 6
- 6 Painted Handicap Symbol, See Detail on Sheet 6
- 7 Painted Parking Striping, 4" Wide at 45 degrees with 4" Wide Perimeter Stripe, Color: White
- 8 Painted Parking Striping, 4" Wide, Color: White
- 9 Structural Stoop, See Architectural Plans For Details
- 10 Loading Dock/Trash Enclosure. See Architectural Plans For Details
- 11 Concrete Filled Steel Pipe Bollard, See Building Plans for Size and Placement at Overhead Doors and Building Corners
- 12 Segmental Block Wall - See Detail on Sheet 6
- 13 Existing Pavement
- 14 PCSMP Basin
- 15 Future Pavement
- 16 Future Building
- 17 Future Segmental Block Wall
- 18 Depress Curb to be Flush with Pavement
- 19 Depress Curb over 6' to be Flush with Pavement at Building

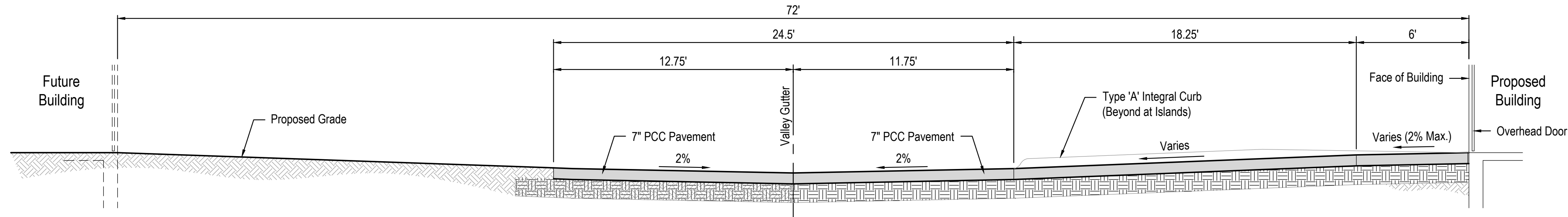
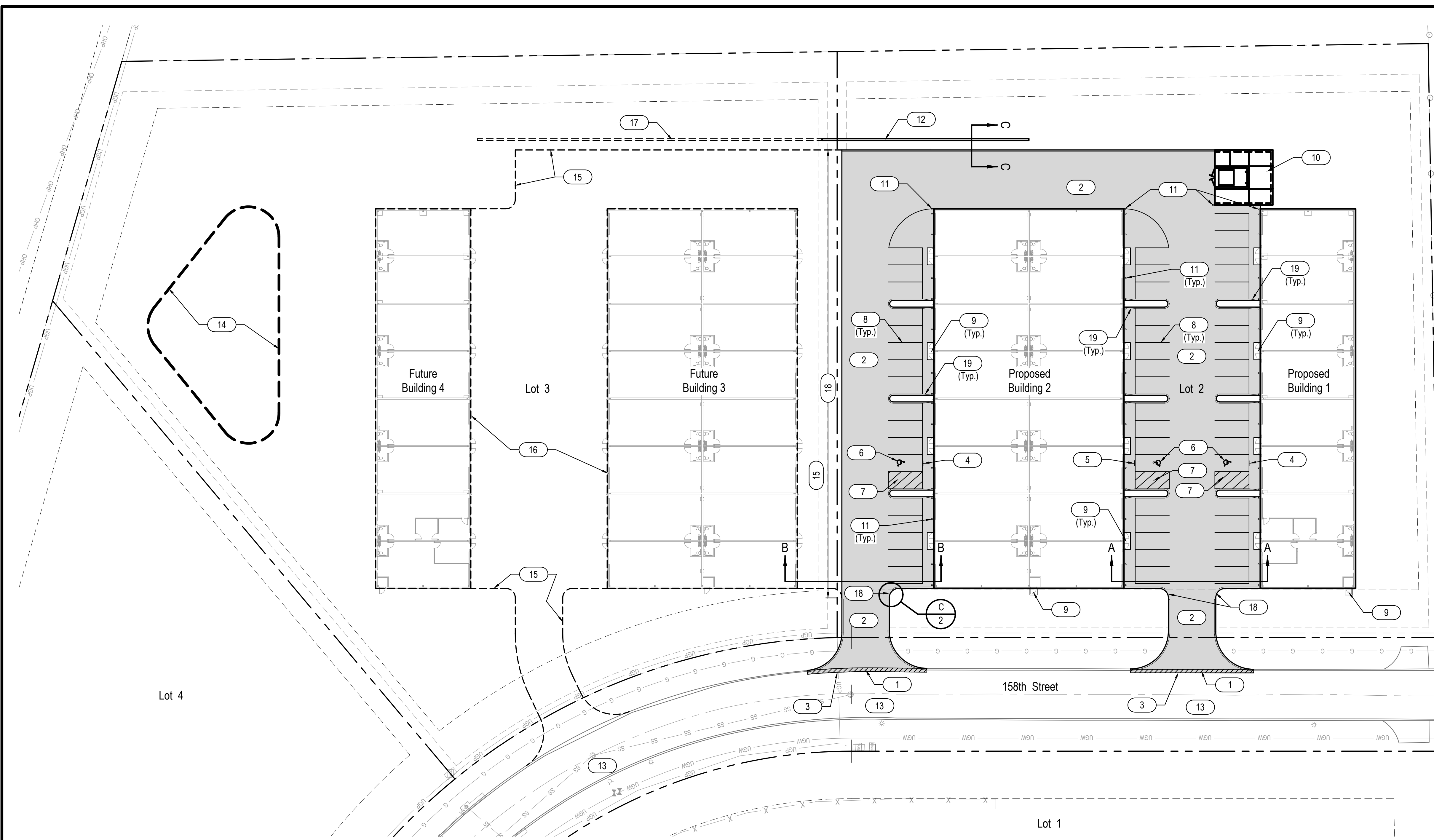

**Section B-B**  
NO SCALE

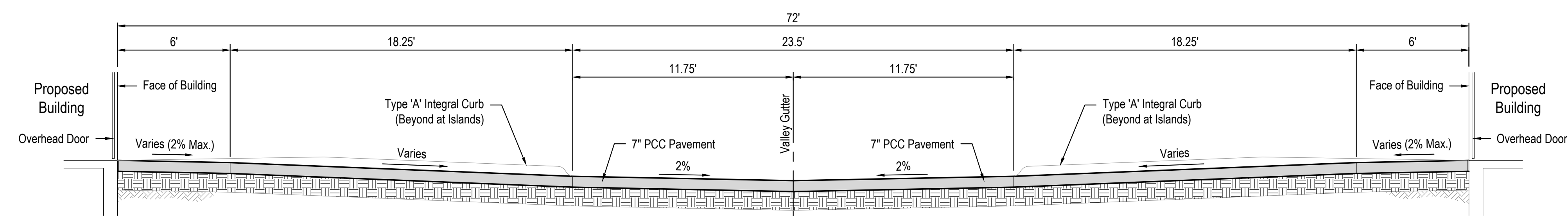

**Section A-A**  
NO SCALE

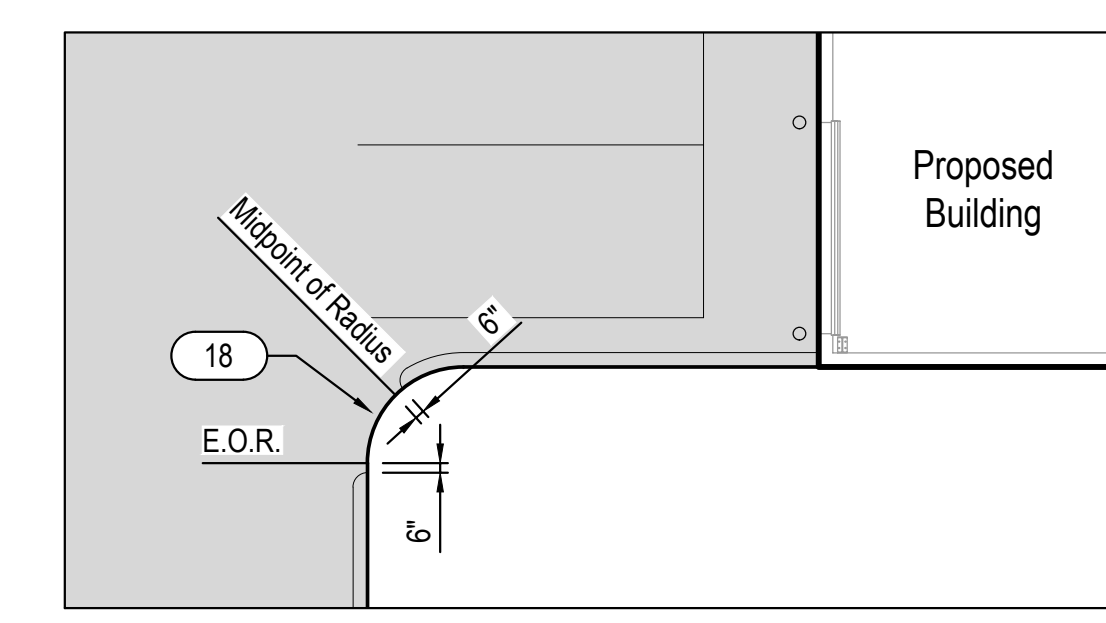

**Drop Curb - Detail C**  
1" = 10'

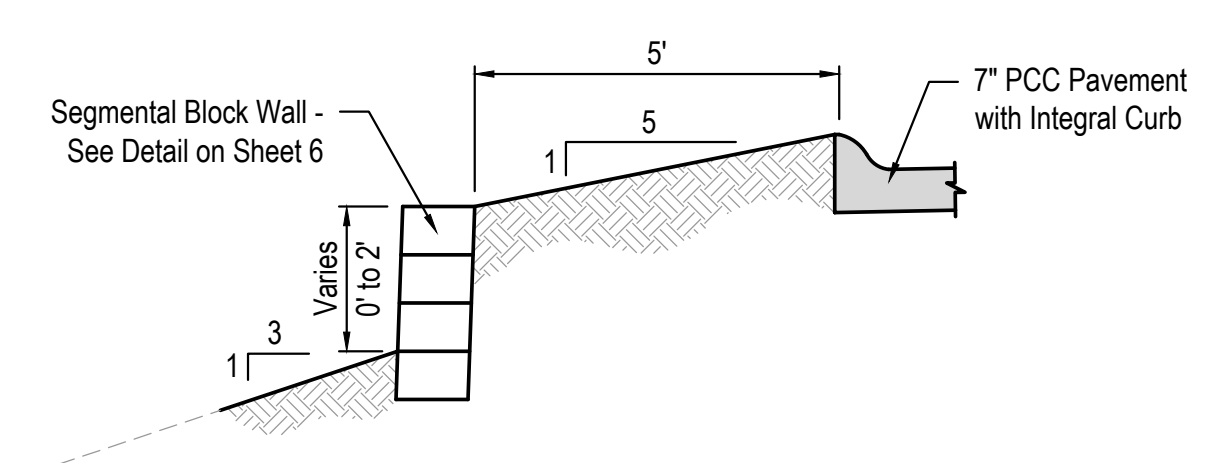

**Section C-C**  
NO SCALE



**CONTRACTOR BAYS**  
 MCGREGOR BRAE - LOTS 2 & 3  
 BENVINGSTON, NEBRASKA

**PAVING AND LAYOUT PLAN**

**Preliminary**  
 Not For Construction  
 10-5-2024

Revisors	Description

Proj No:	P2015.77.013
Date:	10/26/24 1:33 PM
Designed By:	DCW
Drawn By:	E&A
Scale:	AS SHOWN
Sheet:	2 of 12

SEC. 10-T16N-R11E  
(UNPLATTED)

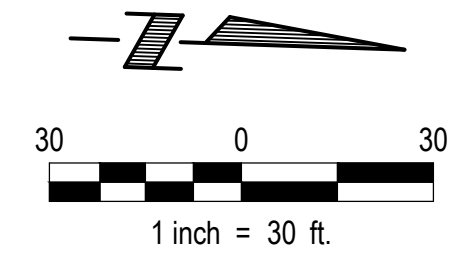

LEGEND

- Sawcut Full Depth and Remove Existing Pavement
- 7" PCC Pavement with Integral Curb
- Segmental Block Retaining Wall

Note: All radii are 5' unless otherwise noted.

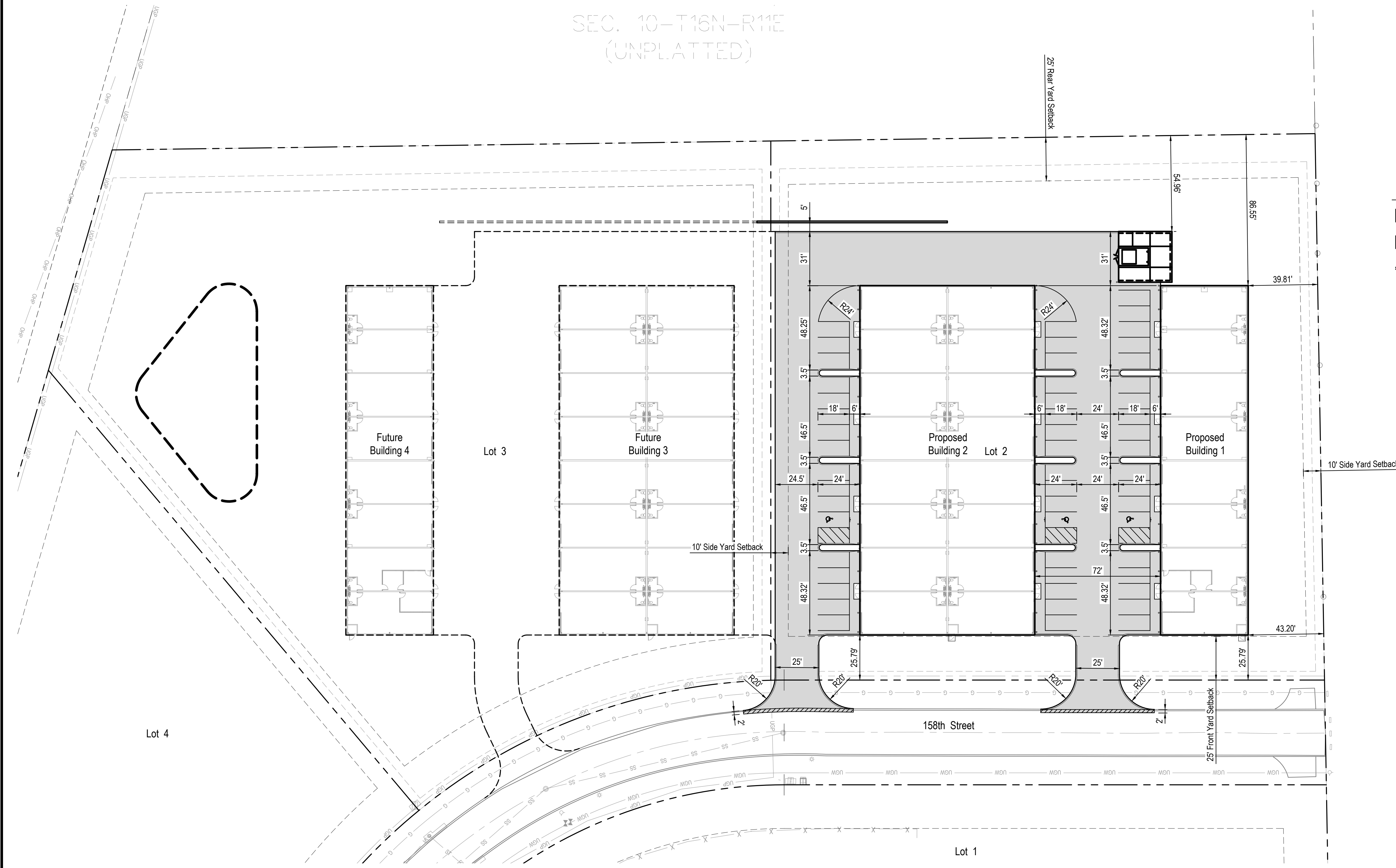

**E & A CONSULTING GROUP, INC.**  
Engineering • Planning • Environmental & Field Services  
10806 Mill Valley Road, Suite 100 • Omaha, NE 68154  
Phone: 402.895.4700 • Fax: 402.895.3999  
www.eaeg.com  
State of NE Certificate of Authorization #C-0008



CONTRACTOR BAYS  
MCGREGOR BRAE - LOTS 2 & 3  
BENNINGTON, NEBRASKA

GEOMETRICS PLAN

Preliminary  
Not For Construction  
10-5-2024

Proj No.	Date	Enter Date	DCW	EA	AS SHOWN	3	of	12
P2015.77.013								

Revisions	Date	Description

See Sheets 10/20/24 1:33 PM K:\Projects\2015\177\17713\Engineering\CAD\Revised\Sheet3 - Paving and Layout.dwg



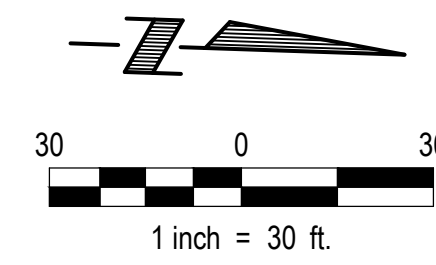

**LEGEND**

	Proposed Contour
	Existing Contour
	Spot Elevation
	Match Existing Spot Elevation
	Top of Wall Elevation
	Ground Elevation at Bottom of Wall
	Ridge Line
	Drainage Swale
	Retaining Wall

- GENERAL GRADING NOTES**
- A Geotechnical Exploration Report has been prepared for this project and is incorporated herein by reference. All recommendations of said report shall be followed in performing grading, paving and utility operations. See "Geotechnical Exploration Report, Bennington Storage Facilities Expansion" prepared for this project by Thiele Geotech, Dated March 23, 2016.
  - Topsoil and Vegetation Shall be Stripped to a Depth of 4" to 6" in Areas to be Graded.
  - Topsoil Obtained from Stripping Operations Shall be Stockpiled in an Approved Location and Re-Spread on Areas Finish Graded to Receive Topsoil.
  - All Fill and Backfill shall be Placed in Lifts of 8" or Less in Loose Thickness.
  - All Fill Areas Shall be Placed and Compacted as Structural Fill. Areas to Receive Fill Shall be Scarified to a Minimum Depth of 12" and Profiled Prior to Receiving Fill. Slopes Steeper than 3H:1V Shall be Benchmarked Before Placing Fill. The Standard Specifications Shall Govern the Grading and Site Preparation with the Exception that Structural Fill Shall be Compacted to a Minimum of 95% of the Maximum Dry Density (ASTM D-698, Standard Proctor) at a Moisture Content Between -3% and +4% of Optimum.
  - For PCC Pavements, The Upper 12" of Subgrade Shall be Compacted to a Minimum of 90% of the Maximum Dry Density (ASTM D-1557, Modified Proctor) at a Moisture Content Between -3% and +4% of Optimum. Subgrade Preparation Shall Extend a Minimum of 2 Feet Beyond the Back of Curb. At all other locations, the pavement subgrade shall be compacted to a minimum of 95% of the Maximum Dry Density (ASTM D-698, Standard Proctor) at a moisture content between -3% and +4% of Optimum.
  - For Sidewalks, The Upper 6" of Subgrade Shall be Compacted to a Minimum of 95% of the Maximum Dry Density (ASTM D-698, Standard Proctor) at a Moisture Content Between -3% and +4% of Optimum. Sidewalk Subgrades Shall Extend at least 6" Laterally Beyond the Edge of the New Sidewalk.
  - Imported Material, If Required, Shall be Free of Organic Matter and Debris, and Shall be an Inorganic Silt or Lean Clay Having a Plasticity Index Less Than 20 and a Liquid Limit less than 45. Borrow Material Shall Not Contain any Foreign Material with a Dimension Greater than 3".
  - Any Excess Material Shall be Stockpiled at a Location Determined by the Contractor.
  - Unless Noted, All Spot Elevations Shown are Top of Slab or Gutter. Add 0.5' to Determine Top of Curb Elevations.

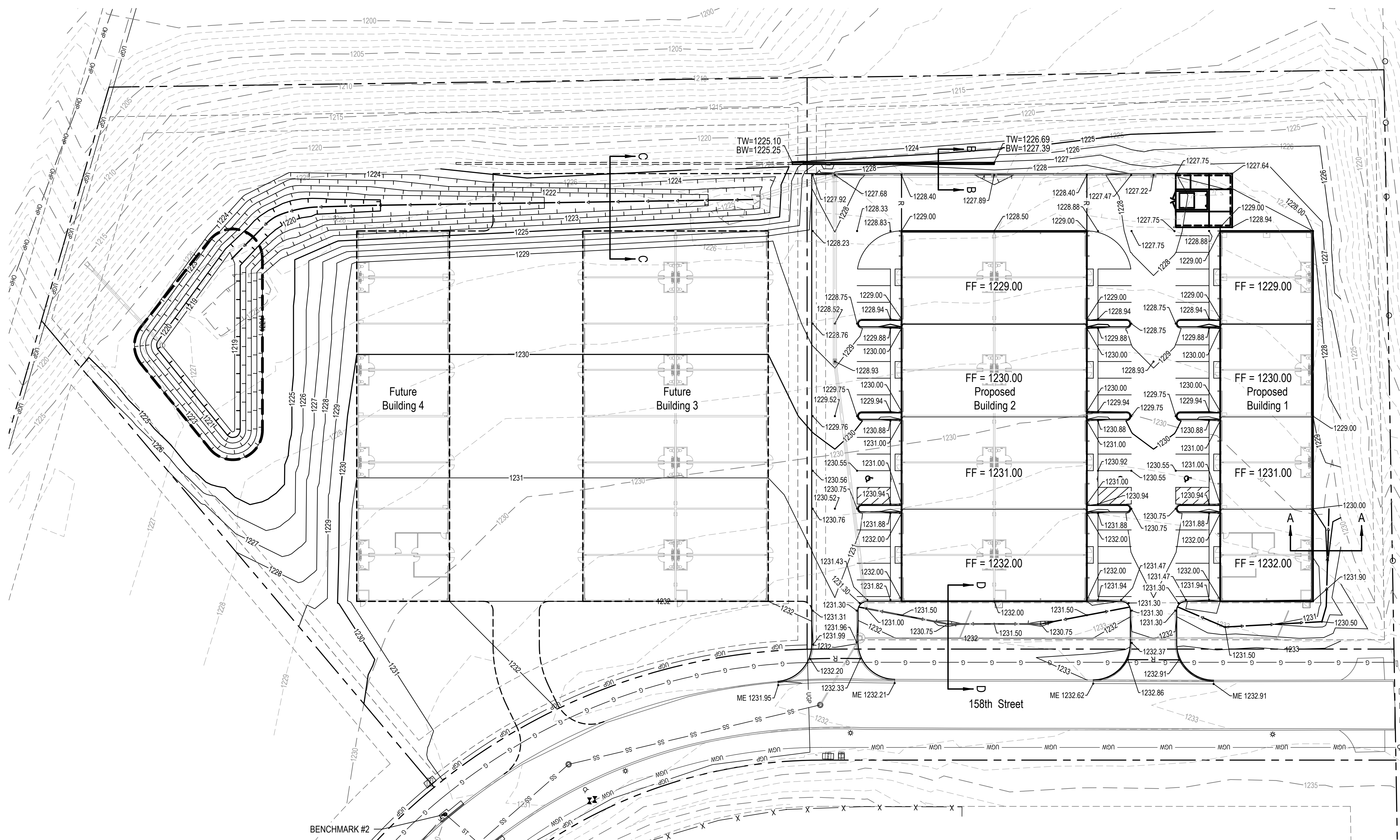

**BENCHMARKS:**

**BENCHMARK #1:** CHISELED "X" NORTH RIM SANITARY MANHOLE, 5TH MANHOLE WEST OF 156TH STREET ON CENTERLINE OF SPRUCE STREET. SHOWN HEREON  
 ELEV: 1232.23'

**BENCHMARK #2:** CHISELED "X" SOUTHWEST RIM OF CURB INLET MANHOLE, 4TH CURB INLET WEST OF 156TH STREET ON SOUTH SIDE OF SPRUCE STREET. SHOWN HEREON.  
 ELEV: 1230.78'

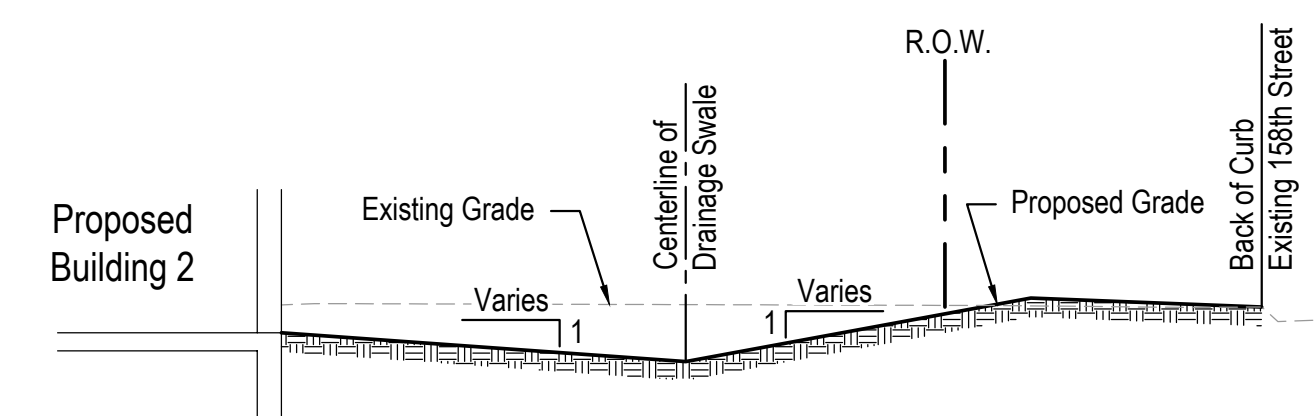

**Section D-D**  
NO SCALE

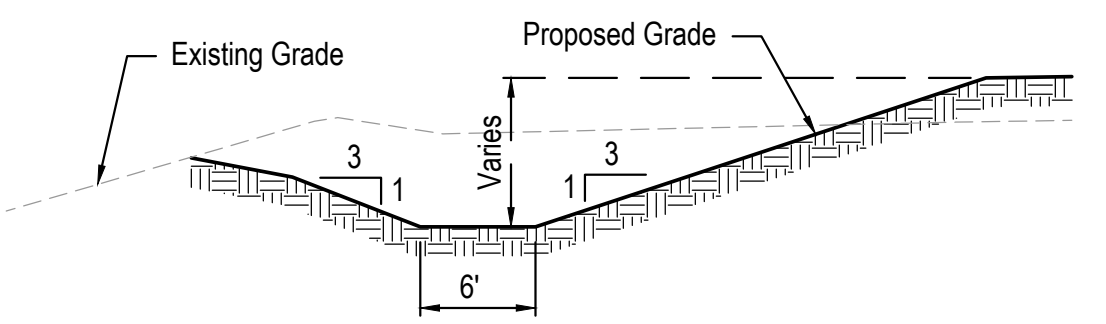

**Section C-C**  
NO SCALE

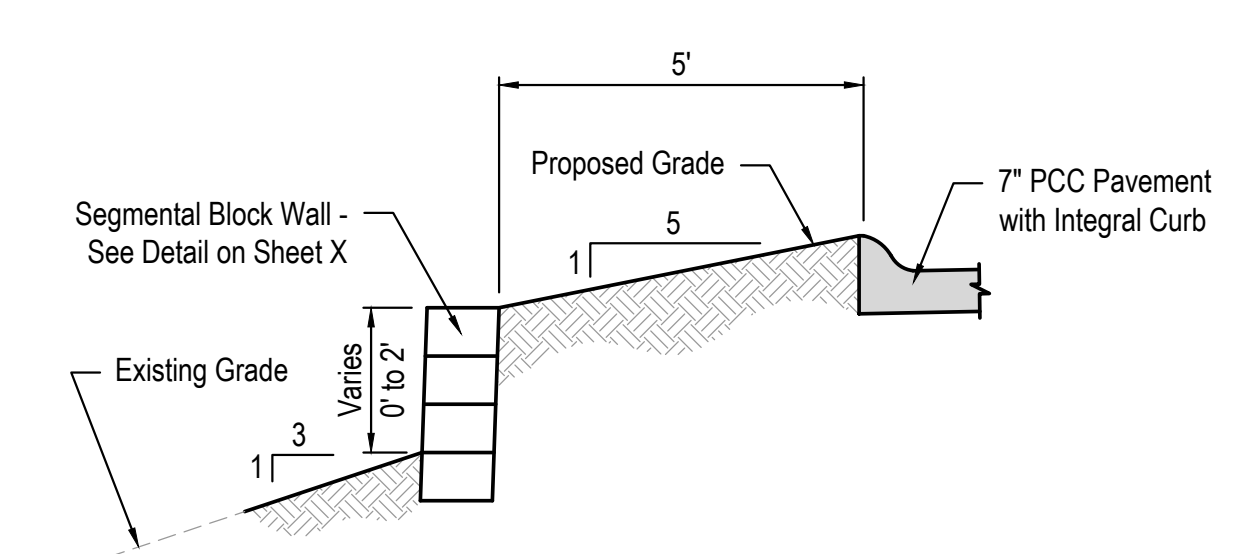

**Section B-B**  
NO SCALE

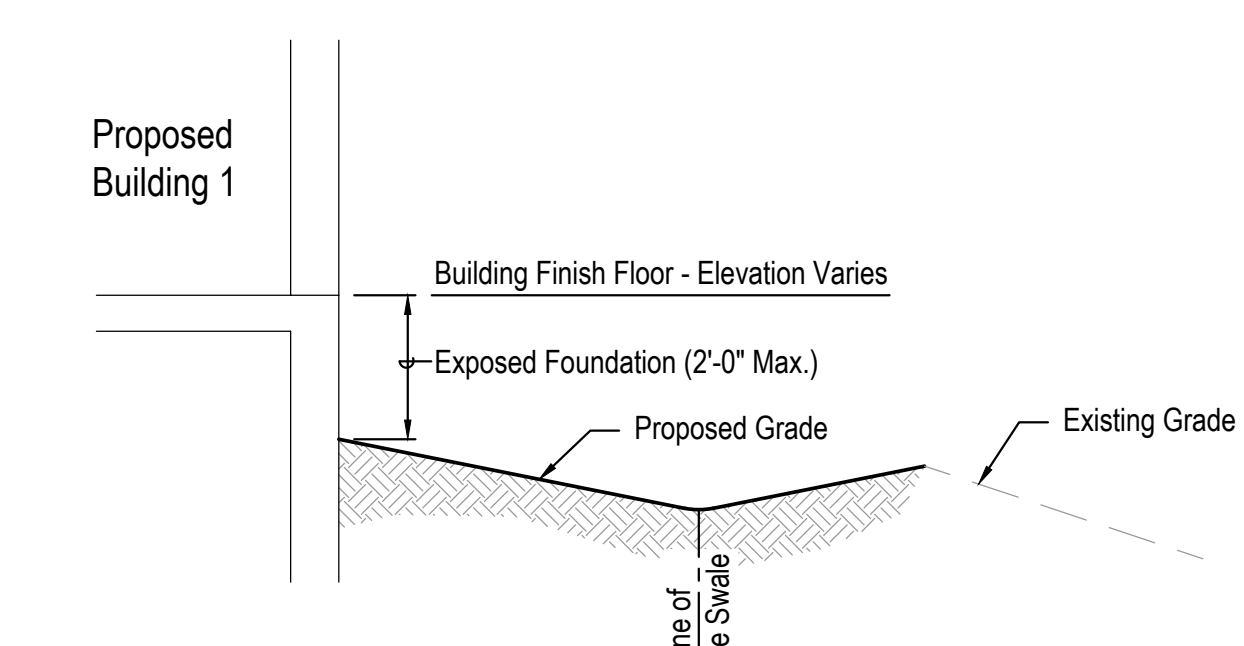

**Section A-A**  
NO SCALE



**CONTRACTOR BAYS**  
 MCGREGOR BRAE - LOTS 2 & 3  
 BENNINGTON, NEBRASKA

**GRADING PLAN**

Preliminary  
 Not For Construction  
 10-5-2024

Proj No:	P2015.77.013
Date:	10/20/24 12:34 PM
Designed By:	DCW
Drawn By:	E&A
Scale:	AS SHOWN
Sheet:	4 of 12

See Details  
 10/20/24 12:34 PM K:\Projects\2015\117\11710\Engineering\CAD\Sheet\04.dwg 6/24/2024 10:00 AM



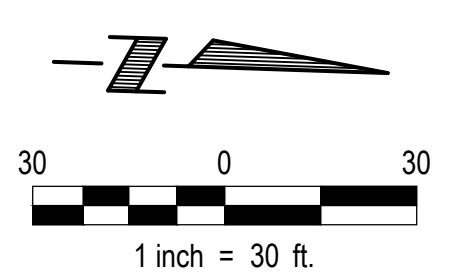

ne1call.com  
**Nebraska 811**  
 know what's below.  
 Call before you dig.  
 Dial: 811

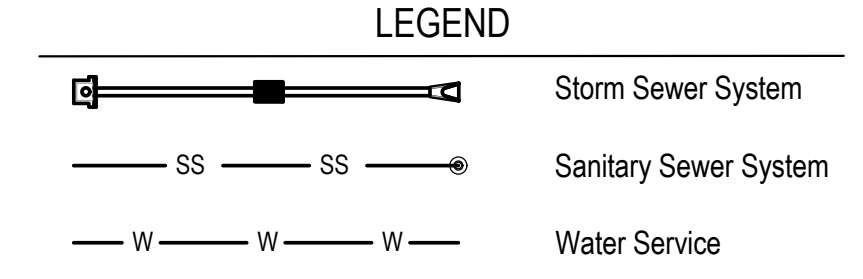

- GENERAL WATER NOTES**
- Coordinate the location, size, and depths of all service lines with building mechanical plans
  - Water lines shall have 5'-0" minimum cover
  - 2" water line shall be copper pipe conforming to MUD requirements. Water pipe construction shall be complete with all Bends, Connections, and Concrete Backing Blocks.
  - Water layout shown is schematic in nature. Minor movement may be required. 10' minimum separation is required between sanitary sewer lines and water lines

- WATER BUILD NOTES**
- W1 Existing M.U.D. Water Main
  - W2 Tapping Tee and Valve by M.U.D. - Contractor Shall Coordinate
  - W3 2" Water Line (See Building Mechanical Plans for Continuation)
  - W4 2" Gate Valve
  - W5 Bore Water Service Under 158th Street
  - W6 Existing Fire Hydrant

- SANITARY SEWER AND STORM SEWER REFERENCE NOTES**
- S1 Existing 8" Sanitary Sewer
  - S2 Existing Sanitary Sewer Manhole. Rim Elev. = 1232.23, FL (8") SE = 1220.75, FL (8") NW = 1220.85 (Field Verify Invert Elevations)
  - S3 Existing 8" Sanitary Sewer Stub
  - S4 Construct New 54" Sanitary Sewer Manhole on Existing 8" Stub. I.E. (8") Out = 1221.10 (Field Verify), I.E. (6") In = 1221.27
  - S5 Construct 225 LF of 8" Sanitary Sewer Pipe @ 1.00%
  - S6 Construct 8" x 6" Service Wye, I.E. = 1221.81
  - S7 6" Service Line @ 1%
  - S8 I.E. (6") = 1221.97 - See Mechanical Plan for Continuation
  - S9 I.E. (6") = 1223.69 - See Mechanical Plan for Continuation
  - S10 Cleanout, See Detail on Sheet 6

**CONSTRUCT STORM SEWER STRUCTURE**

NO.	DESCRIPTION
C1	Curb Inlet, Top of Curb = 1228.18, Rim = 1227.68 FL (18" In) = 1223.17 FL (24" Out) = 1222.67 FL (15" In) = 1223.42
C2	Curb Inlet, Top of Curb = 1228.40, Rim = 1227.90 FL (18" In) = 1223.60 FL (18" Out) = 1223.60
DC1	Double Curb Inlet, Top of Curb = 1227.72, Rim = 1227.22 FL (18" Out) = 1224.03
F1	Flared End Section, Rim = 1224.69 FL (24" In) = 1222.27
F2	Flared End Section, Rim = 1217.21 FL (12" In) = 1215.92
G1	Grate Inlet, Rim = 1228.93 FL (15" Out) = 1224.97 FL (12" In) = 1225.22
R1	Basin Riser, Rim = 1222.50 FL (12" Out) = 1219.00
Y1	Yard Inlet with 12" Grated Cover, Rim = 1231.00 FL (8" In) = 1227.63 FL (12" Out) = 1227.30
Y2	Yard Inlet with 12" Grated Cover, Rim = 1230.75 FL (8" In) = 1228.08 FL (8" Out) = 1228.08
Y3	Yard Inlet with 12" Grated Cover, Rim = 1230.75 FL (8" Out) = 1228.58

**CONNECTION VERIFICATION NOTE:**  
 The Contractor shall field verify the location, diameter, and invert elevation of the existing pipe and/or structure prior to the start of any construction. The Contractor shall notify the Engineer of any discrepancies between the field verified information and the information shown on the plans.

**CONSTRUCT STORM SEWER PIPE**

ID	START STRUCTURE	END STRUCTURE	Dia.	Length	Slope	Remarks
S11	C1	F1	24"	40.18	1.00%	
S12	C2	C1	18"	86.07	0.50%	
S13	DC1	C2	18"	86.07	0.50%	
S15	G1	C1	15"	100.55	1.54%	
S16	Y1	G1	12"	134.52	1.54%	
S17	Y2	Y1	8"	44.92	1.00%	
S18	Y3	Y2	8"	50.00	1.00%	
S19	R1	F2	12"	54.76	5.62%	

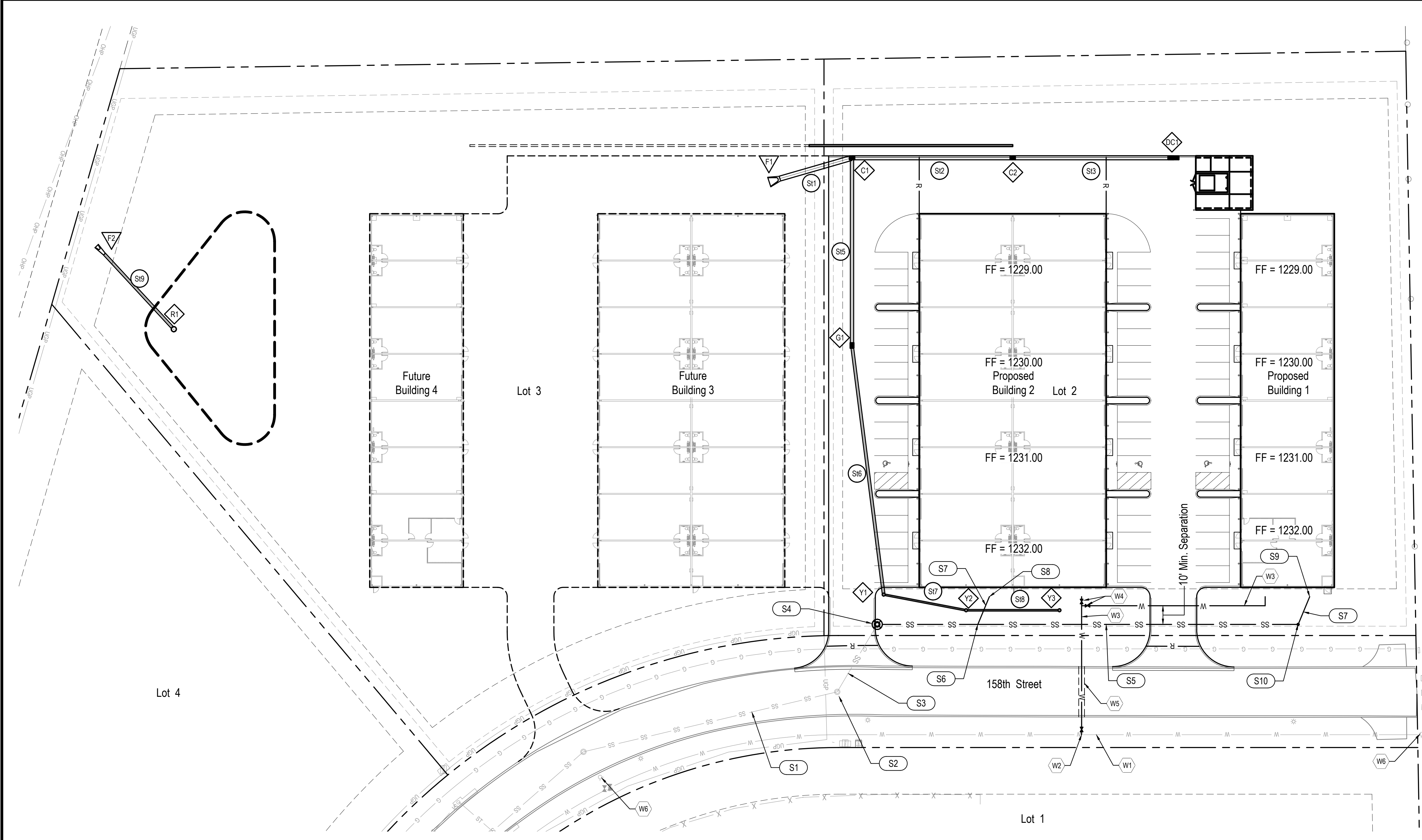

**E & A CONSULTING GROUP, INC.**  
 Engineering • Planning • Environmental & Field Services  
 10808 Mill Valley Road, Suite 100 • Omaha, NE 68154  
 Phone: 402.895.4700 • Fax: 402.895.3999  
 www.eaeg.com  
 State of NE Certificate of Authorization #C-0008

**E & A CONSULTING GROUP, INC.**  
 Engineering Answers

**CONTRACTOR BAYS**  
 MCGREGOR BRAE - LOTS 2 & 3  
 BENVINGTON, NEBRASKA

**UTILITY PLAN**

**Preliminary**  
 Not For Construction  
 10-5-2024

Proj No:	P2015.77.013
Date:	10/26/24 12:34 PM
Designed By:	DCW
Drawn By:	E&A
Scale:	AS SHOWN
Sheet:	5 of 12

10/26/24 12:34 PM K:\Projects\2015\177\1015\Engineering\CAD\HELOC\Sheet5.dwg - Ulmer.dwg



**GENERAL SITE CONSTRUCTION NOTES**

- The City of Omaha Standard Specifications for Public Works Construction, 2024 Edition and any current revisions or amendments thereto and the Special Provisions for this Project shall apply and the Contractor shall perform in accord therewith.
- The Contractor shall check with the Owner for City approval of the project before starting work.
- Utilities are shown as a convenience for the Contractor. The locations of all aerial and underground utility facilities may not be indicated in these plans. Underground utilities, whether indicated or not, will be located and flagged by the utility companies at the Contractor's request. No excavation will be permitted in the area of the underground utilities until all facilities have been located and identified to the satisfaction of all parties and then only with extreme care to avoid any possibility of damages to the facilities.
- The Portland Cement Concrete for the pavement slab shall be OPW 3500, in accord with the Standard Specifications.
- Portland Cement Concrete mix design for sidewalks shall be City of Omaha Type OPW 3500 mix.
- Erosion control improvements shall be constructed on this site, including inlet protection, silt fencing and a construction entrance. The Contractor shall be responsible for prompt reconstruction of any erosion control improvements disturbed by his operations. All disturbed erosion control improvements shall be fully reconstructed at the end of each working day prior to leaving the site. Separate payment will not be made for reconstruction of any erosion control improvements. Positive drainage in all work areas shall be maintained in the condition the construction site was in prior to Contractors arrival.
- Non-colored concrete pavement shall be cured using a white pigmented liquid membrane-forming curing compound that has been approved by the State of Nebraska Department of Roads. The minimum rate of application shall be 200 sq. ft. per gal. if a mechanical-powered sprayer is used and 100 sq. ft. per gal. if a hand powered sprayer is used.
- Water reducing admixtures shall be added to all hand-placed and finished concrete.
- A diamond edge saw blade shall be used for cutting all required contraction and longitudinal pavement joints.
- "CreteDefender P2" shall be applied to all pavement joints a minimum of 1' in each direction from the joint. Install per manufacturer's recommendation.
- Concrete pavement shall be jointed in maximum 12.5' x 15' panels and shall be kept as square as possible. Joints shall be perpendicular to edges and radiuses, and shall not form angles less than 45 degrees or over 225 degrees.
- The 8 inch (Solid Wall) sanitary sewer pipe may be ABS (SDR 26), PVC (SDR 26), or VCP. The 6 inch (Solid Wall) sanitary sewer pipe may be ABS (SDR 23.5), PVC (SDR 23.5), or VCP.
- The following storm sewer pipe materials may be used:
  - Reinforced Concrete Pipe (RCP), conforming to ASTM C76 (Class III unless otherwise indicated). Materials and installation shall conform to City of Omaha Standard Specifications.
  - PVC pipe with smooth interior and corrugated exterior, such as Contech A-2000, or equal. Pipe and fittings shall conform to ASTM F949. Installation shall conform to ASTM D 2321. Gasketed joints shall be used, and shall show no leakage when tested in accordance with ASTM D 3212.
  - PVC pipe, SDR -35, in accordance with ASTM D 3034. Installation shall conform to ASTM D 2321. Gasketed joints shall be used, and shall show no leakage when tested in accordance with ASTM D 3212.
  - Polyethylene pipe, with smooth interior and corrugated exterior, such as ADS N-12, Hancor HI-Q, or equal. Pipe and fittings shall conform to AASHTO M-252 and M-294. Installation shall conform to ASTM D 2321. Joints shall be made with split couplings, corrugated to engage the pipe corrugations, and shall engage a minimum of 2 corrugations on each side of the pipe joint. A neoprene gasket, per the manufacturer's recommendations, shall be used for all joints to ensure a soil-tight connection. Class IV soils shall not be used for bedding or backfill of N-12 pipe.
  - Backfill soils in utility trenches, around foundations, basement walls, and retaining walls shall be compacted to a minimum of 98% of the maximum dry density (ASTM D-698, Standard Proctor) at a moisture content between -3% and +3% of the optimum for soils with less than 12% passing the #200 sieve, and between 0% and +4% of optimum for soils with more than 12% passing the #200 sieve. Lift thickness shall be appropriately matched to the type of compaction equipment used.
- Curb Inlets shall be Nyloplast curb inlets with 2'x3' diagonal flow grates, or approved equals.
- Double Curb Inlets shall be Nyloplast double curb inlets with 2'x3' diagonal flow grates, or approved equals.
- Grate Inlets shall be a Nyloplast Drain Basin with 2' x 3' diagonal flow grate, or approved equal. Nyloplast basin size shall be determined by manufacturer based on pipe alignment and diameter.
- Drain Basins shall be Nyloplast Drain Basins with Solid Covers, or approved equal. Nyloplast basin sizes shall be determined by manufacturer based on pipe alignment and diameter.
- Yard Inlets shall be Nyloplast Drain Basins with light duty grate tops, or approved equal. Nyloplast basin sizes shall be determined by manufacturer based on pipe alignment and size.
- Standard Plates are available from the City of Omaha Public Works Department, 1819 Farnam St., Suite 600, Omaha NE, 68183, PH 402.444.5220. Plates may also be downloaded via the internet from the City of Omaha Web Site at: <http://www.ci.omaha.ne.us/publicworks/standardplates.htm>
- The following Standard Plates on file at the City of Omaha Public Works Department shall govern:

PLATE NO.	DESCRIPTION	REVISION DATE
501-01	Concrete Pavement Joints	02/13/2024
501-13-01	Concrete Driveway	02/13/2024
501-13-02	Concrete Driveway	02/13/2024
502-01	Concrete Curbs	02/13/2024
605-01	Segmental Retaining Walls	02/13/2024
701-01-01	Sewer Bedding	02/13/2024
701-01-02	Sewer Bedding	02/13/2024
701-01-03	Sewer Bedding	02/13/2024
703-03	Sanitary Sewer Manhole	02/13/2024

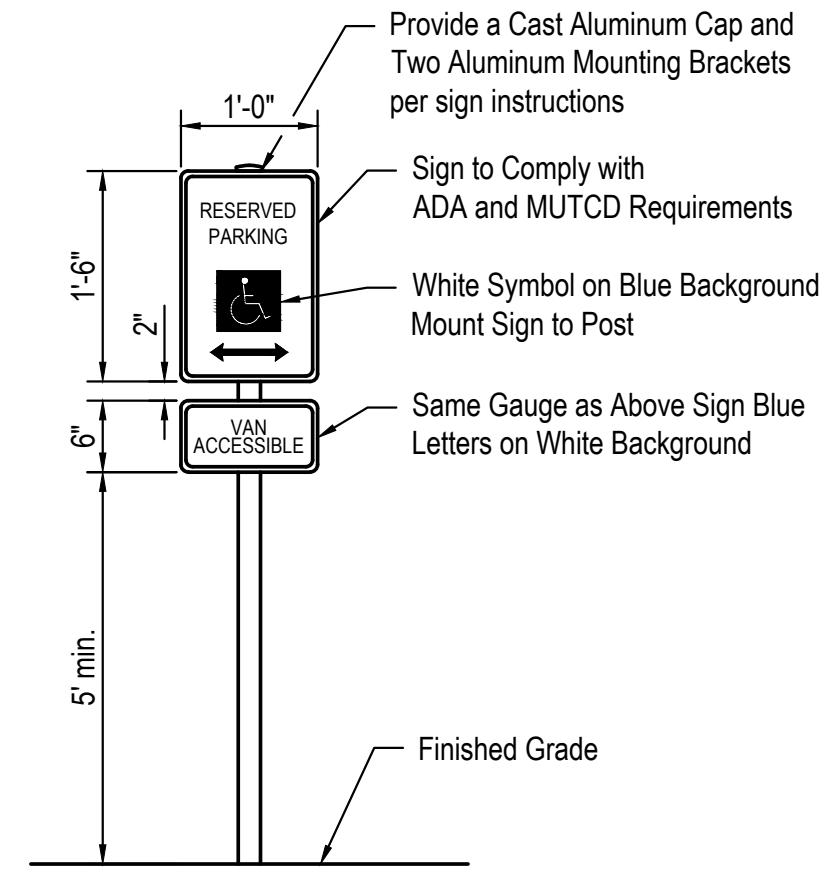

**HANDICAP PARKING SIGN**  
NOT TO SCALE

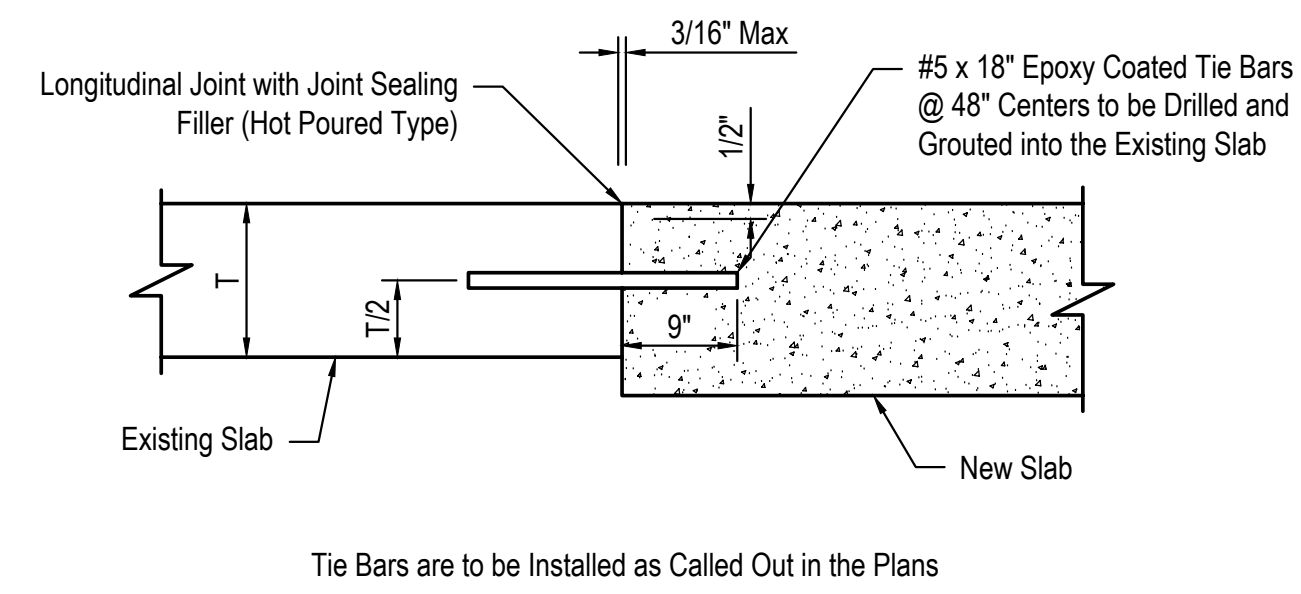

**TIE BAR DETAIL**  
NOT TO SCALE

Tie Bars are to be Installed as Called Out in the Plans

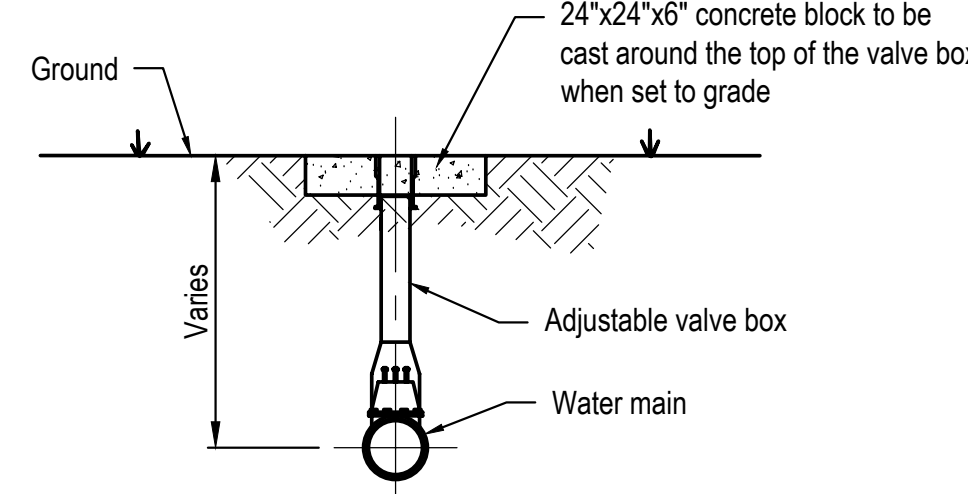

**VALVE BOX SETTING**  
NOT TO SCALE

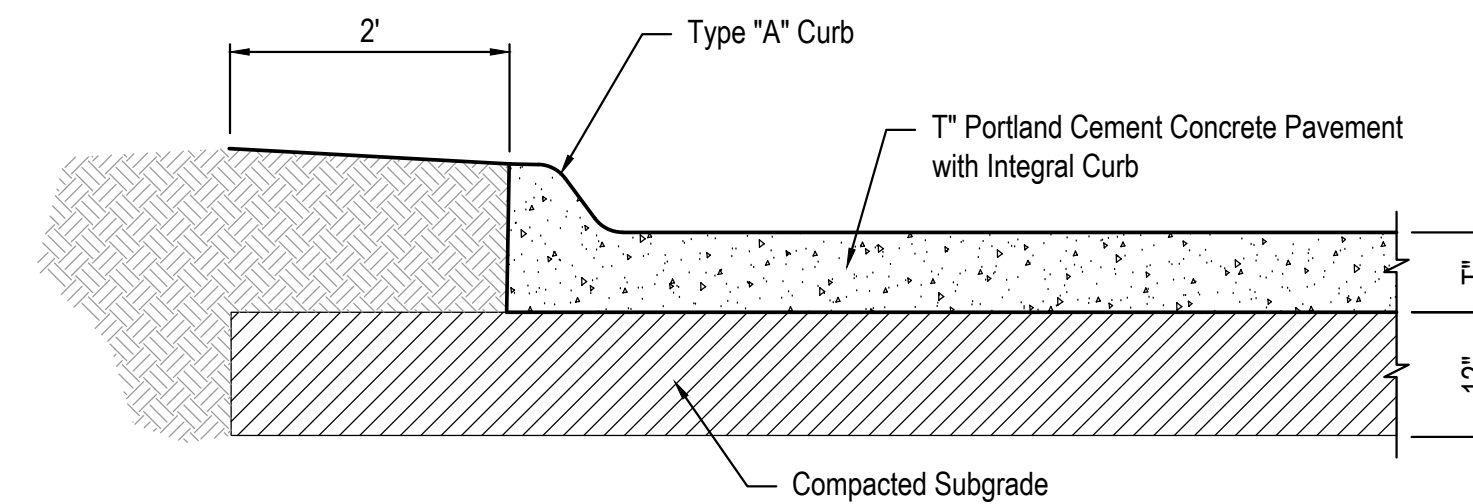

Note: T = Thickness of P.C.C. Pavement Indicated on the Paving and Layout Plan

**T' PORTLAND CEMENT PAVEMENT WITH INTEGRAL CURB SECTION**  
NOT TO SCALE

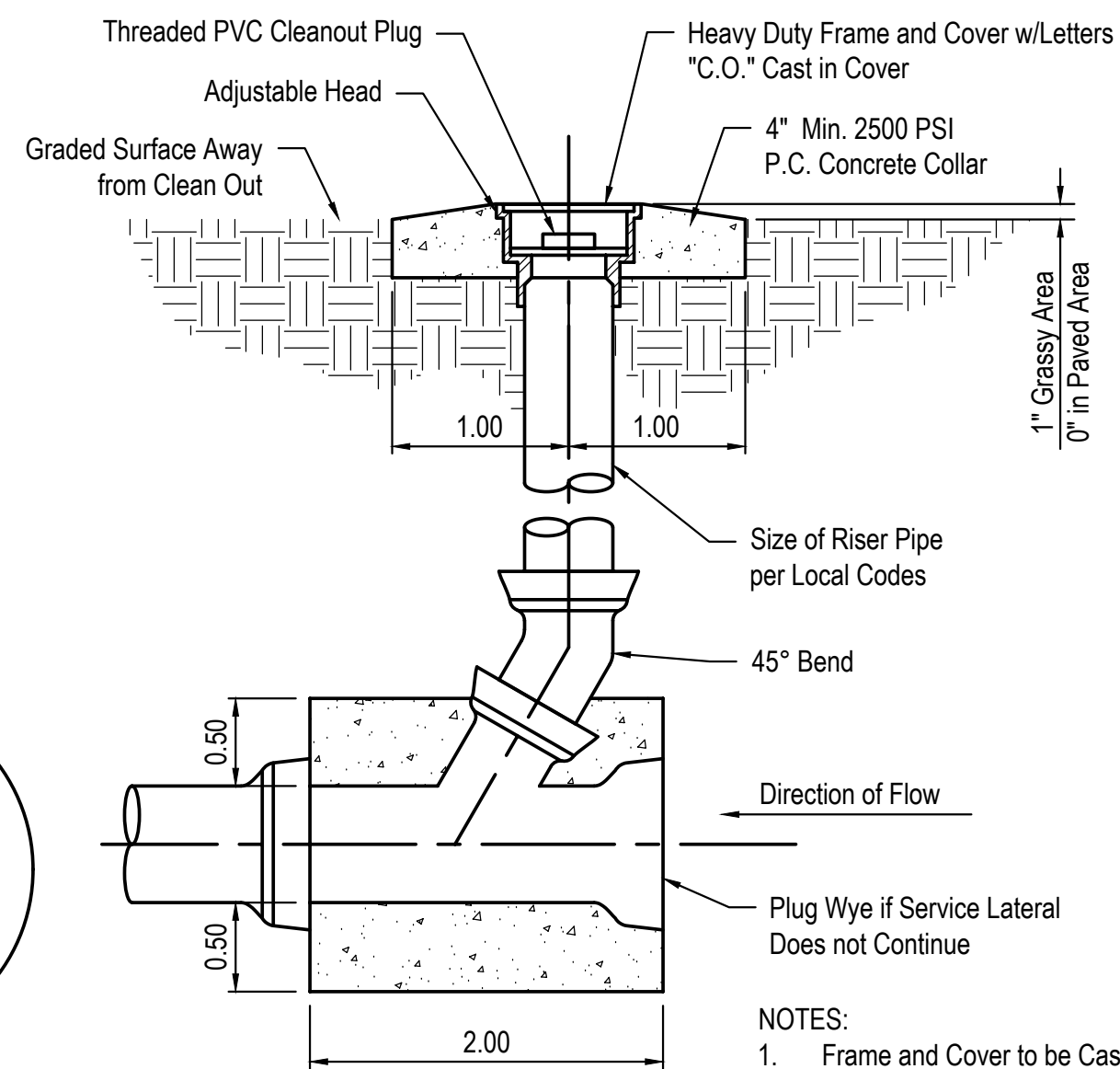

**SANITARY CLEANOUT DETAIL**  
NOT TO SCALE

- NOTES:
- Frame and Cover to be Cast Iron. Approx. Weight is 70 Lbs.
  - Cover to Have the Letters "C.O." Cast on Top
  - Concrete Rest Block Shall be 2.0' Long x O.D. of Pipe + 6" on Each Side

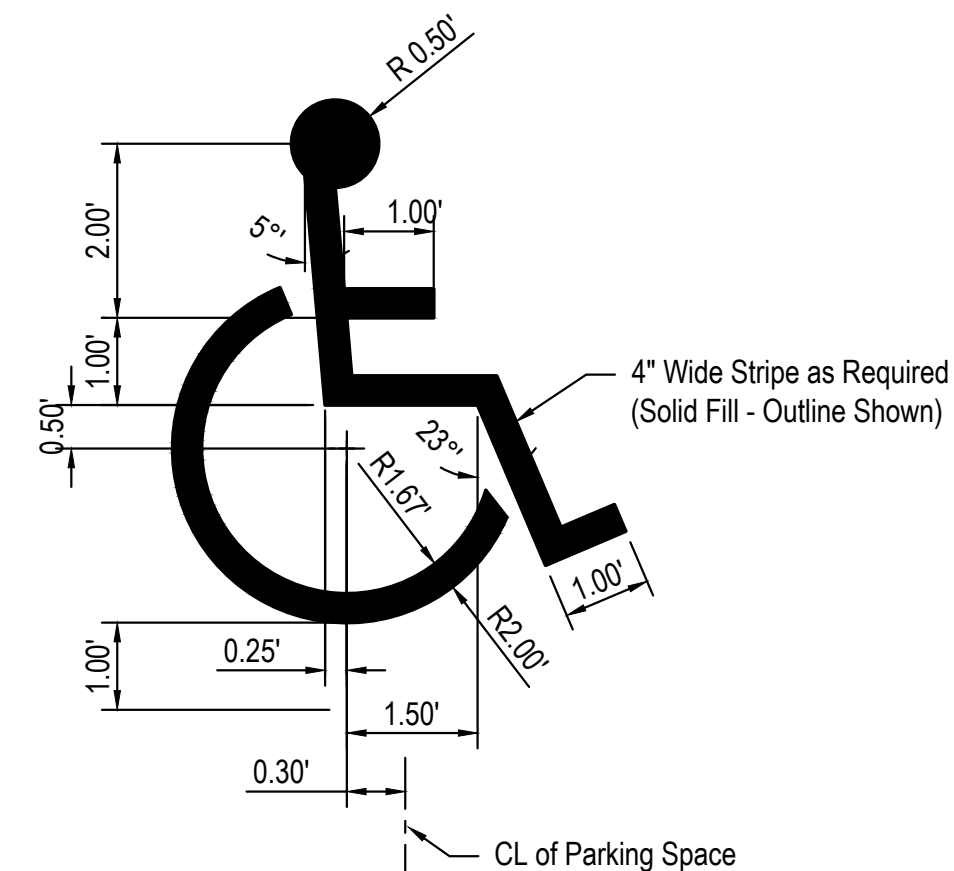
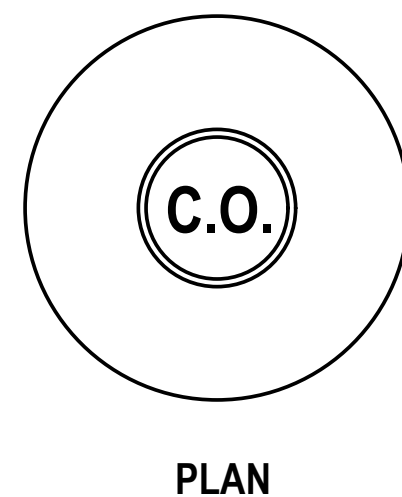

**HANDICAP PARKING STALL STENCIL DETAIL**  
NOT TO SCALE

**NOTES**

- Paint Color by Surface:  
Pavement Surface    Paint Color  
Concrete                Yellow  
Bituminous            White
- Paint Shall Conform to Federal Specification: TT-P-115 (2 Coats)

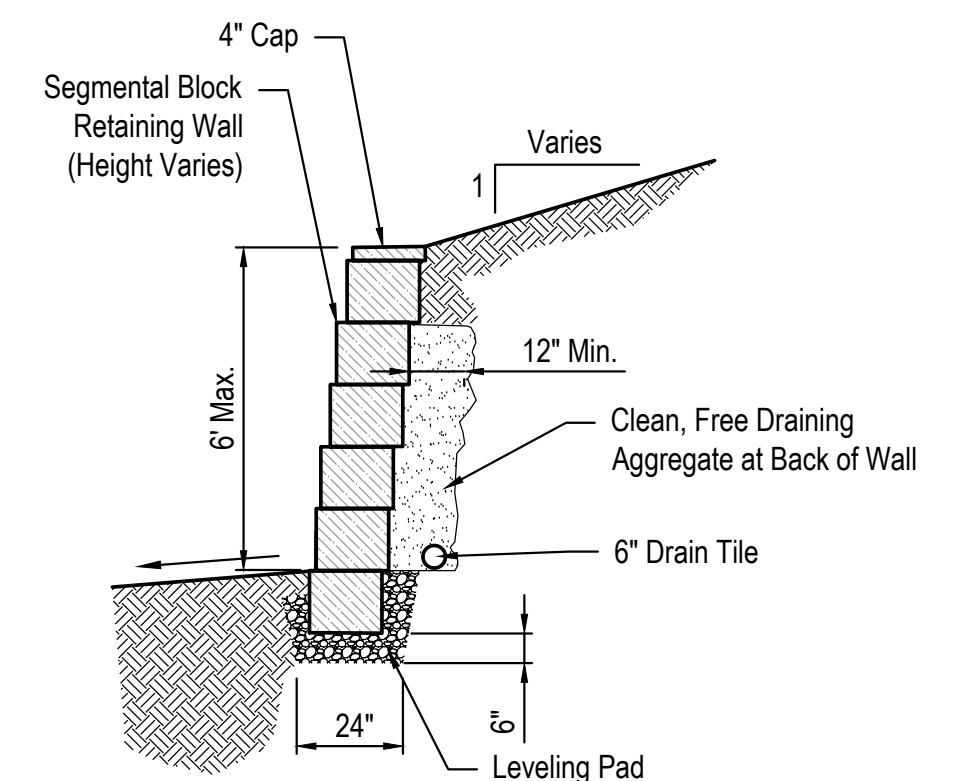

**SEGMENTAL BLOCK RETAINING WALL**  
NOT TO SCALE

Segmental Block Wall Shall be: Anchor Vertica Pro, Color: Midnight (Verify Color with Owner)

ne1call.com  
**Nebraska 811**  
know what's below.  
Call before you dig.  
Dial: 811

**E & A CONSULTING GROUP, INC.**  
Engineering • Planning • Environmental & Field Services  
10806 Mill Valley Road, Suite 100 • Omaha, NE 68154  
Phone: 402.895.4700 • Fax: 402.895.3999  
www.eaeg.com  
State of NE Certificate of Authorization #C-0008

**E & A CONSULTING GROUP, INC.**  
Engineering Answers

CONTRACTOR BAYS  
MCGREGOR BRAE - LOTS 2 & 3  
BENNINGTON, NEBRASKA

GENERAL NOTES AND DETAILS

Preliminary  
Not For Construction  
10-5-2024

Revisions	Description	Date

Proj No:	P2015.7.7.013
Date:	Enter Date
Designed By:	DCW
Drawn By:	E&A
Scale:	AS SHOWN
Sheet:	6 of 12

Joe Baratta    10/26/24 12:34 PM    K:\Projects\2015\171913\Engineering\CAD\Sheet\03 - Paving and Layout.dwg



- BUILD NOTES - LAYOUT**
- (NO) **BUILD NOTES - LAYOUT**
  - (CE-1) **CONSTRUCT STONE CONSTRUCTION ENTRANCE** - See Figure 9-3 per ORSWDM
  - (SF-X) **CONSTRUCT SILT FENCE** - See Detail on This Sheet. Install J-Hook every 100 LF
  - (IF-X) **CONSTRUCT INLET FILTER** - Install 9" Diameter Wattle Type Filter, or approved other, per manufacturer's recommendations
  - (MS-1) **PROPOSED MATERIAL STORAGE AREA** - Alternate Location Shall be Approved By the INSPECTOR
  - (WS-1) **PROPOSED WASTE STORAGE AREA** - Alternate Location Shall be Approved By the INSPECTOR
  - (WO-1) **INSTALL CONCRETE WASHOUT FACILITY** - See Detail on This Sheet. Alternate Product or Location Shall be Approved By the INSPECTOR
  - (D-X) **TEMPORARY DIVERSION DIKE** - See Figure 9-13 per ORSWDM
  - 1 Silt fence across driveway shall be removed to construct driveway
  - 2 Silt fence at curb ramps shall be removed to construct curb ramps

- LEGEND**
- 1220 — Proposed Contour
  - - - 1220 - - - Existing Contour
  - R — R — Ridge Line
  - SF — Silt Fence
  - ↔ Inverted Crown
  - ◡ Inlet Filter

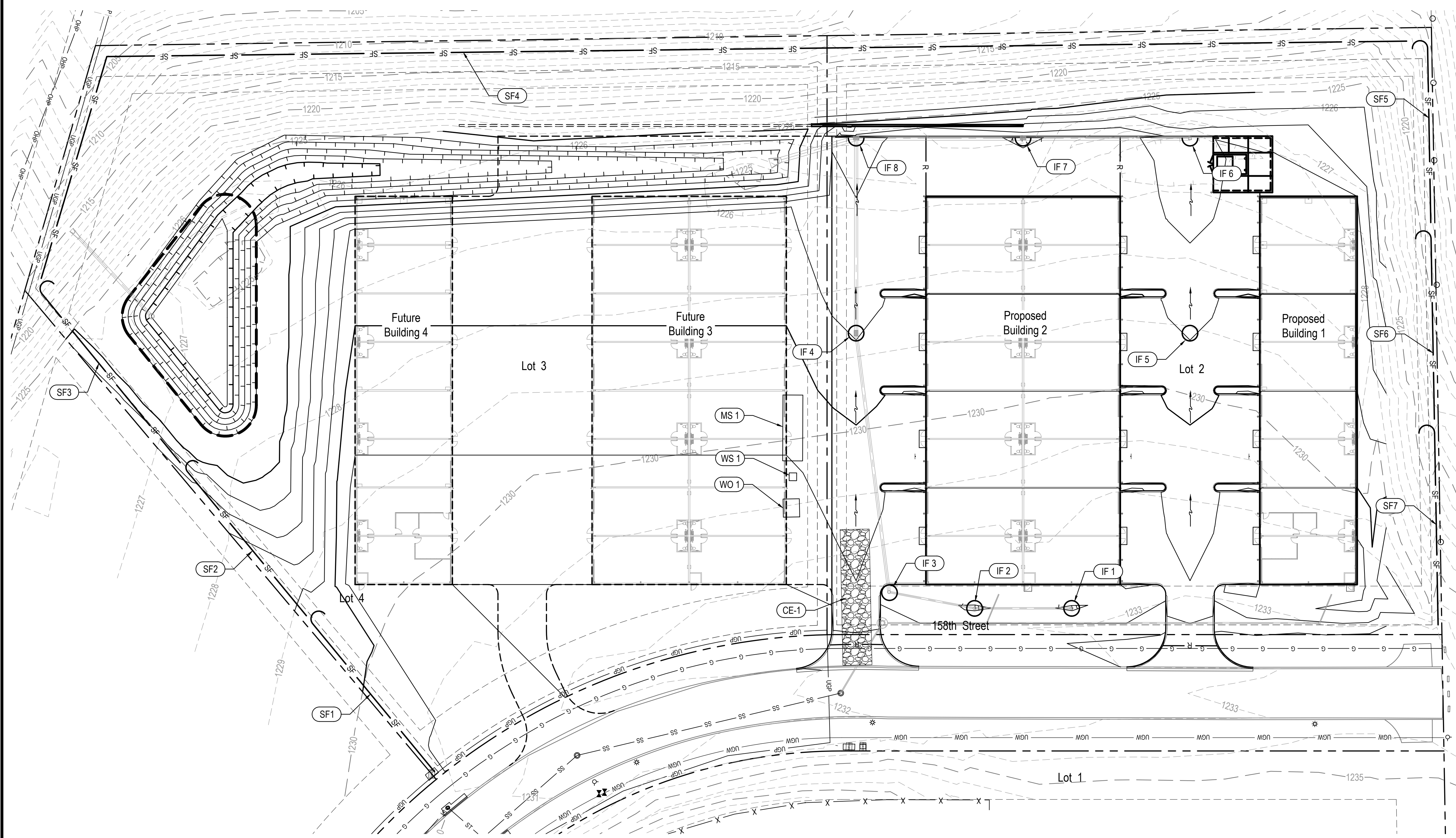
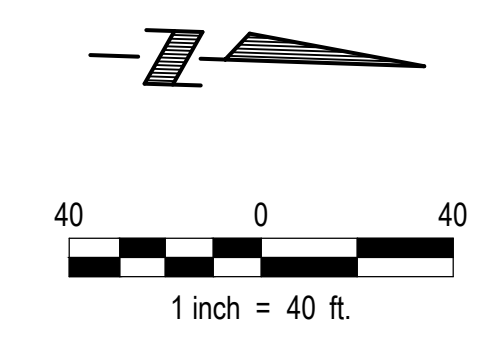

**STORM WATER POLLUTION PREVENTION PLAN GENERAL NOTES**

1. Project procedures and materials shall conform to the following publication and any additions thereto: Omaha Regional Stormwater Design Manual and the SWPPP Map Preparation Guide. The aforementioned publications can be found at: <https://omahastormwater.org>.
2. OPERATORS/CONTRACTORS shall comply with noise and dust control ordinances.
3. OPERATORS/CONTRACTORS shall locate existing utilities prior to the start of work. (One Call 811).
4. Barricades shall conform to Omaha Public Works "Barricading Standards, Specifications, Methods & Materials", and/or the "Manual on Uniform Traffic Control Devices".
5. OPERATORS/CONTRACTORS shall be responsible for compliance with OSHA Regulations.
6. OPERATORS/CONTRACTORS shall confirm with the applicant that governmental approvals have been received prior to the start of work.
7. The APPLICANT and INSPECTOR shall comply with government regulations to minimize the potential for erosion and pollution.
8. OPERATORS/CONTRACTORS shall perform construction activities as directed by the applicant, inspector, and government regulators to minimize the potential for erosion and pollution.
9. Each OPERATOR/CONTRACTOR shall monitor silt fencing, inlet protection, and other Best Management Practices (BMPs), within their areas of responsibility, and install additional BMPs as necessary and as directed by the INSPECTOR.
10. Each OPERATOR/CONTRACTOR shall periodically remove accumulated sediment from temporary sediment traps, temporary sediment basins, behind silt fences, and other erosion control measures that store sediment, within their areas of responsibility, if necessary and as directed by the INSPECTOR.
11. Each OPERATOR/CONTRACTOR shall build stabilized construction entrances, within their areas of responsibility and as defined within the SWPPP. Each OPERATOR/CONTRACTOR shall monitor and maintain stabilized construction entrances within their areas of responsibility as needed or as directed by the INSPECTOR. OPERATORS/CONTRACTORS shall not use any other access to the site or allow others to use alternate access points.
12. Each OPERATOR/CONTRACTOR shall maintain and perform preventative maintenance on each best management practice (BMP), within their areas of responsibility, to ensure their function. The Inspector shall ensure preventative maintenance is being performed.
13. BMP's shall be kept in working order. Each OPERATOR/CONTRACTOR shall repair any defects or damages, within their areas of responsibility, at or before the end of each working day or as directed by the Inspector.
14. BMP's may not be removed without INSPECTOR and applicable governmental approval.
15. Each OPERATOR/CONTRACTOR shall be responsible for adhering to BMP's within their areas of responsibility.
16. In the event of a release of oil or hazardous substance, OPERATORS/CONTRACTORS shall comply with the requirements of the Nebraska Department of Environmental Quality for Notification, Containment, Investigation, Remedial Action and Disposal.
17. The APPLICANT, INSPECTOR and CONTRACTORS/OPERATORS shall ensure temporary diversion dikes and temporary fill diversions are constructed as shown within the SWPPP And as necessary to properly control pollutant discharge. Temporary diversion dikes and temporary fill diversions shall be installed at the end of each working day, prior to all rain events, and as directed by the Inspector.
18. The APPLICANT, INSPECTOR, and/or OPERATORS/CONTRACTORS shall allow government regulators access to the site for inspections at any time, at the implementing agency's discretion.
19. The APPLICANT, INSPECTOR and CONTRACTORS/OPERATORS must initiate stabilization measures, such as temporary seeding, permanent seeding, and/or mulching, as soon as possible on portions of the site where construction activities have temporarily or permanently ceased, but in no case more than 14 days after construction activity on that portion of the site where work has ceased. Temporary Seeding (9.5.19), Permanent Seeding (9.5.20), and Mulching (9.5.22) BMP's Presented within the Omaha Regional Stormwater Design Manual shall be adhered to at all times. This publication can be found at: <https://omahastormwater.org>.
20. For dust control, the APPLICANT, INSPECTOR AND CONTRACTORS/OPERATORS may use the following measures, singularly or in combination: establish temporary seeding, establish permanent seeding, mulch in areas subject to little or no construction traffic; irrigate stripped areas and/or haul roads; reduce vehicular speed on haul roads; or other options as directed by the inspector. Furthermore, the Dust Control (9.5.16) BMP presented within the Omaha Regional Stormwater Design Manual shall be adhered to at all times.
21. The APPLICANT, INSPECTOR and CONTRACTORS/OPERATORS shall ensure sediment transported onto public streets is removed as needed, prior to rain events and, at a minimum, at the end of each working day. Sediment shall be shoveled and/or swept from the street and disposed of in a manner that prevents stormwater contamination. Furthermore, the Street Cleaning/Sweeping (9.6.5) BMP presented within the Omaha Regional Stormwater Design Manual shall be adhered to at all times.
22. The APPLICANT, INSPECTOR and CONTRACTORS/OPERATORS shall adhere to all good housekeeping bmp's presented within the Omaha Regional Stormwater Design Manual. Good housekeeping BMP's Focus on keeping the work site clean and orderly while handling materials and waste in a manner that eliminates the potential for pollutant runoff. Good housekeeping BMP's such as Sanitary Waste Management (9.6.2), Solid Waste Management (9.6.3), Material Delivery & Storage (9.6.4), Street Cleaning/Sweeping (9.6.5), and Vehicle & Equipment Fueling (9.6.6) shall be addressed when applicable.
23. To better inform all concerned parties about the existence of the SWPPP, the APPLICANT, INSPECTOR and CONTRACTORS/OPERATORS shall ensure an easily visible and legible sign be prominently posted at conspicuous locations near site entry points. Signs must be in conformance with the SWPPP Notification Sign (9.6.7) presented within the Omaha Regional Stormwater Design Manual.
24. The SWPPP documents (e.g., NDEE-NPDES, SWPPP-SM, SWPPP-N, ETC.) are essential and a requirement in one part is binding as though occurring in all. The documents describe and provide the complete SWPPP. The APPLICANT, INSPECTOR and/or CONTRACTORS/OPERATORS may not take advantage of any SWPPP errors or omissions. The INSPECTOR shall notify the APPLICANT, DESIGNER and CONTRACTORS/OPERATORS promptly of any omissions or errors within one business day of discovery. The APPLICANT shall instruct the DESIGNER to make any corrections necessary to fulfill the overall intent of the SWPPP documents (e.g., Grading Permit Modification Form). In the case of a discrepancy between parts of the SWPPP documents, the most stringent requirement shall rule.



**CONTRACTOR BAYS**  
 MCGREGOR BRAE - LOTS 2 & 3  
 BENVINGTON, NEBRASKA

**STORMWATER POLLUTION PREVENTION PLAN**

**Preliminary Not For Construction 10-5-2024**

Revisions	Date	Description

CSW NO.

Proj No:	P2015.77.013
Date:	10/20/24 12:34 PM
Designed By:	DCW
Drawn By:	E&A
Scale:	AS SHOWN
Sheet:	7 of 12



**STORM WATER POLLUTION PREVENTION PLAN GENERAL NOTES**

- Project procedures and materials shall conform to the following publication and any additions thereto: Omaha Regional Stormwater Design Manual and the SWPPP Map Preparation Guide. The aforementioned publications can be found at: <https://omahastormwater.org>.
- OPERATORS/CONTRACTORS shall comply with noise and dust control ordinances.
- OPERATORS/CONTRACTORS shall locate existing utilities prior to the start of work. (One Call 811).
- Barricades shall conform to Omaha Public Works "Barricading Standards, Specifications, Methods & Materials", And/or the "Manual on Uniform Traffic Control Devices".
- OPERATORS/CONTRACTORS shall be responsible for compliance with OSHA Regulations.
- OPERATORS/CONTRACTORS shall confirm with the applicant that governmental approvals have been received prior to the start of work.
- The APPLICANT and INSPECTOR shall comply with government regulations to minimize the potential for erosion and pollution.
- OPERATORS/CONTRACTORS shall perform construction activities as directed by the applicant, inspector, and government regulators to minimize the potential for erosion and pollution.
- Each OPERATOR/CONTRACTOR shall monitor silt fencing and other Best Management Practices (BMPs), within their areas of responsibility, and install additional BMPs as necessary and as directed by the INSPECTOR.
- Each OPERATOR/CONTRACTOR shall periodically remove accumulated sediment from temporary sediment traps, temporary sediment basins, behind silt fences, and other erosion control measures that store sediment, within their areas of responsibility, if necessary and as directed by the INSPECTOR.
- Each OPERATOR/CONTRACTOR shall build stabilized construction entrances, within their areas of responsibility and as defined within the SWPPP. Each OPERATOR/CONTRACTOR shall monitor and maintain stabilized construction entrances within their areas of responsibility as needed or as directed by the INSPECTOR. OPERATORS/CONTRACTORS shall not use any other access to the site or allow others to use alternate access points.
- Each OPERATOR/CONTRACTOR shall maintain and perform preventative maintenance on each best management practice (BMP), within their areas of responsibility, to ensure their function. The Inspector shall ensure preventative maintenance is being performed.
- BMPs shall be kept in working order. Each OPERATOR/CONTRACTOR shall repair any defects or damages, within their areas of responsibility, at or before the end of each working day or as directed by the Inspector.
- BMPs may not be removed without INSPECTOR and applicable governmental approval.
- Each OPERATOR/CONTRACTOR shall be responsible for adhering to BMPs within their areas of responsibility.
- In the event of a release of oil or hazardous substance, OPERATORS/CONTRACTORS shall comply with the requirements of the Nebraska Department of Environmental Quality for Notification, Containment, Investigation, Remedial Action and Disposal.
- The APPLICANT, INSPECTOR and CONTRACTORS/OPERATORS shall ensure temporary diversion dikes and temporary fill diversions are constructed as shown within the SWPPP And as necessary to properly control pollutant discharge. Temporary diversion dikes and temporary fill diversions shall be installed at the end of each working day, prior to all rain events, and as directed by the Inspector.
- The APPLICANT, INSPECTOR, and/or OPERATORS/CONTRACTORS shall allow government regulators access to the site for inspections at any time, at the implementing agency's discretion.
- The APPLICANT, INSPECTOR and CONTRACTORS/OPERATORS must initiate stabilization measures, such as temporary seeding, permanent seeding, and/or mulching, as soon as possible on portions of the site where construction activities have temporarily or permanently ceased, but in no case more than 14 days after construction activity on that portion of the site where work has ceased. Temporary Seeding (9.5.19), Permanent Seeding (9.5.20), and Mulching (9.5.22) BMPs Presented within the Omaha Regional Stormwater Design Manual shall be adhered to at all times. This publication can be found at: <https://omahastormwater.org>.
- For dust control, the APPLICANT, INSPECTOR AND CONTRACTORS/OPERATORS may use the following measures, singularly or in combination: establish temporary seeding, establish permanent seeding, mulch in areas subject to little or no construction traffic; irrigate stripped areas and/or haul roads; reduce vehicle speed on haul roads; or other options as directed by the inspector. Furthermore, the Dust Control (9.5.16) BMP presented within the Omaha Regional Stormwater Design Manual shall be adhered to at all times.
- The APPLICANT, INSPECTOR and CONTRACTORS/OPERATORS shall ensure sediment transported onto public streets is removed as needed, prior to rain events and, at a minimum, at the end of each working day. Sediment shall be shoveled and/or swept from the street and disposed of in a manner that prevents stormwater contamination. Furthermore, the Street Cleaning/Sweeping (9.6.5) BMP presented within the Omaha Regional Stormwater Design Manual shall be adhered to at all times.
- The APPLICANT, INSPECTOR and CONTRACTORS/OPERATORS shall adhere to all good housekeeping bmp's presented within the Omaha Regional Stormwater Design Manual. Good housekeeping BMP's Focus on keeping the work site clean and orderly while handling materials and waste in a manner that eliminates the potential for pollutant runoff. Good housekeeping BMP's such as Sanitary Waste Management (9.6.2), Solid Waste Management (9.6.3), Material Delivery & Storage (9.6.4), Street Cleaning/Sweeping (9.6.5), and Vehicle & Equipment Fueling (9.6.6) shall be addressed when applicable.
- To better inform all concerned parties about the existence of the SWPPP, the APPLICANT, INSPECTOR and CONTRACTORS/OPERATORS shall ensure an easily visible and legible sign be prominently posted at conspicuous locations near site entry points. Signs must be in conformance with the SWPPP Notification Sign (9.6.7) presented within the Omaha Regional Stormwater Design Manual.
- The SWPPP documents (e.g., NDEE-NPDES, SWPPP-SM, SWPPP-N, ETC.) are essential and a requirement in one part is binding as though occurring in all. The documents describe and provide the complete SWPPP. The APPLICANT, INSPECTOR and/or CONTRACTORS/OPERATORS may not take advantage of any SWPPP errors or omissions. The INSPECTOR shall notify the APPLICANT, DESIGNER and CONTRACTORS/OPERATORS promptly of any omissions or errors within one business day of discovery. The APPLICANT shall instruct the DESIGNER to make any corrections necessary to fulfill the overall intent of the SWPPP documents (e.g., Grading Permit Modification Form). In the case of a discrepancy between parts of the SWPPP documents, the most stringent requirement shall rule.

**MAINTENANCE SCHEDULE**

- The following Maintenance Schedule has been provided. The INSPECTOR must perform the Inspections. The OPERATOR/CONTRACTOR must perform all needed maintenance. Furthermore, all erosion control features requiring maintenance may not be listed below. The OPERATOR/CONTRACTOR and INSPECTOR must perform their respective duties on all BMP's that are not listed below as well.
- Construction Entrance** - The entrance shall be maintained in a condition which will prevent tracking or flow of sediment onto public rights-of-way. This may require periodic top dressing with additional stone or the washing and reworking of existing stone as conditions demand and repair and/or cleanout of any structures used to trap sediment. All materials spilled, dropped, washed, or tracked from vehicles onto roadways or into storm drains must be removed immediately. The use of water trucks to remove materials dropped, washed, or tracked onto roadways will not be permitted under any circumstances.
- Silt Fence** - The maintenance measures are as follows; (2.1) silt fences shall be inspected immediately after each rainfall and at least daily during prolonged rainfall, any required repairs shall be made immediately; (2.2) close attention shall be paid to the repair of damaged silt fence resulting from end runs and undercutting; (2.3) should the fabric on a silt fence decompose or become ineffective prior to the end of the expected usable life and the barrier is still necessary, the fabric shall be replaced promptly; (2.4) sediment deposits must be removed when the level of deposition reaches approximately one-half the height of the barrier; and (2.5) any sediment deposits remaining in place after the silt fence is no longer required shall be dressed to conform to the existing grade, prepared and seeded.
- Storm Drain Inlet Protection** - The maintenance measures are as follows; (3.1) structures shall be inspected after each rain and repairs made as necessary and (3.2) structures shall be removed and the area stabilized when the remaining drainage area has been properly stabilized.
- Temporary Diversion Dike** - The measure shall be inspected after every storm and repairs made to the dike, flow channel, outlet or sediment trapping facility, as necessary. Once every two weeks, whether a storm event has occurred or not, the measure shall be inspected and repairs made if needed. Damages caused by construction traffic or other activity must be repaired before the end of each working day.
- Temporary Fill Diversion** - Since the practice is temporary and under most situations will be covered the next working day. The maintenance required should be low. If the practice is to remain in use for more than one day, an inspection shall be made at the end of each work day and repairs made to the measure if needed. The OPERATOR/CONTRACTOR should avoid the placement of any material over the structure while it is in use. Construction traffic should not be permitted to cross the diversion.
- Temporary Sediment Trap** - The maintenance measures are as follows: (6.1) sediment shall be removed and the trap restored to its original dimensions when the sediment has accumulated to one half the design volume of the wet storage, sediment removal from the basin shall be deposited in a suitable area and in such a manner that it will not erode and cause sedimentation problems; (6.2) filter stone shall be regularly checked to ensure that filtration performance is maintained, stone choked with sediment shall be removed and cleaned or replaced; and (6.3) the structure should be checked regularly to ensure that it is structurally sound and has not been damaged by erosion or construction equipment, the height of the stone outlet should be checked to ensure that its center is at least 1 foot below the top of the embankment.
- Temporary Sediment Basin** - The basin embankment should be checked regularly to ensure that it is structurally sound and has not been damaged by erosion or construction equipment. The emergency spillway should be checked regularly to ensure that its lining is well established and erosion-resistant. The basin should be checked after each runoff producing rainfall for sediment cleanout and trash removal. When the sediment reaches the cleanout level, it shall be removed and properly disposed of.
- Temporary Seeding** - Areas which fail to establish vegetative cover adequate to prevent rill erosion will be re-seeded as soon as such areas are identified. Control weeds by mowing.
- Permanent Seeding** - The maintenance measures are as follows: (9.1) in general, a stand of vegetation cannot be determined to be fully established until it has been maintained for one full year after planting; (9.2) new seedlings shall be supplied with adequate moisture, supply water as needed, especially late in the season, in abnormally hot or dry conditions, or on adverse sites, water applications shall be controlled to prevent excessive runoff; (9.3) inspect all seeded areas for failures and make necessary repairs, replacements, and reseedings within the planting season, if possible; (9.3a) if stand is inadequate for erosion control, over seed and fertilize using half of the rates originally specified; (9.3b) if stand is 60% damaged, re-establish following seedbed and seeding recommendations; (9.3c) if stand has less than 40% cover, re-evaluate choice of plant materials and quantities of lime and fertilizer, the soil must be tested to determine if acidity or nutrient imbalances are responsible, re-establish the stand following seedbed and seeding recommendations.
- Mulching** - All mulches and soil coverings should be inspected periodically (particularly after rainstorms) to check for erosion. Where erosion is observed in mulched areas, additional mulch should be applied. Nets and mats should be inspected after rainstorms for dislocation or failure. If washouts or breakage occur, reinstall netting or matting as necessary after repairing damage to the slope or ditch. Inspections should take place until grasses are firmly established. Where mulch is used in conjunction with ornamental plantings, inspect periodically throughout the year to determine if mulch is maintaining coverage of the soil surface; repair as needed.
- Soil Stabilization Blankets & Matting** - All soil stabilization blankets and matting should be inspected periodically following installation, particularly after rainstorms to check for erosion and undermining. Any dislocation or failure should be repaired immediately. If washouts or breakage occurs, reinstall the material after repairing damage to the slope or ditch. Continue to monitor these areas until which time they become permanently stabilized; at that time an annual inspection should be adequate.
- Street Cleaning/Sweeping** - The maintenance measures are as follows; (12.1) evaluate access points daily for sediment tracking; (12.2) when tracked or spilled sediment is found on paved surfaces, it will be removed daily, during times of heavy track-out such as during rains, cleaning may be done several times throughout the day; (12.3) unknown spills or objects will not be mixed with the sediment; and (12.4) if sediment is mixed with other pollutants, it will be disposed of properly at an authorized landfill.

**CONSTRUCTION ACTIVITIES & SCHEDULING**

**ACTIVITY**

Install all BMP's needed and associated with the Grading Phase such as stabilized construction entrances, silt basins, riser pipes, outlet pipes, silt traps, silt fence, diversions, terraces, and etcetera.

Proceed with removals, stripping of existing vegetation, and grading in accordance with the grading plan, while disturbing no more than necessary.

Proceed with infrastructure installation.

Implement the installation of Temporary Seeding, Permanent Seeding, and/or Mulching.

Implement the installation all BMP's needed and associated with the Building Phase.

Proceed with removal of BMP's.

**SCHEDULE**

Prior to any stripping of existing vegetation, grading, removals, or other ground disturbing activity.

After installing all BMP's needed and associated with the Grading Phase. Furthermore, INSPECTOR approval must be obtained before the start of any stripping of existing vegetation or grading.

Infrastructure installation must occur prior to any lot development.

Stabilization measures must be initiated as soon as possible in portions of the site where construction activities have temporarily or permanently ceased, but in no case more than 14 days after the construction activity in that portion of the site has temporarily or permanently ceased.

Building Phase BMP's must be installed concurrently with lot development.

BMP's may not be removed until each impacted drainage basin has been fully developed. Full development shall mean installation of pavement, buildings, and utilities, landscaping, and fully established permanent seeding. Furthermore, INSPECTOR approval must be obtained before the removal of any BMP's.

ne1call.com  
**Nebraska 811**  
 know what's below.  
 Call before you dig.  
 Dial: 811

**SITE INFORMATION**

Estimated Start Date	PCWP Project Number	NDEE CSW Number
Project Name		Address
Subdivision Name	S & ID #	City
Latitude		Longitude
State		Zip Code
Total Site Area (Acres)		Estimated Permit Duration (Months)
Disturbed Area (Acres)		Cut Volume (YD <sup>3</sup> )
Undisturbed Area (Acres)		Fill Volume (YD <sup>3</sup> )
Impervious Area Before Construction (%)		Runoff Coefficient Before Construction
Impervious Area After Construction (%)		Runoff Coefficient After Construction

**APPLICANT SWPPP CERTIFICATION**

Business Name	Representative's Email Address	Phone Number
Representative's Name	Address	Fax Number
Project # Assigned by Applicant	City	State
		Zip Code

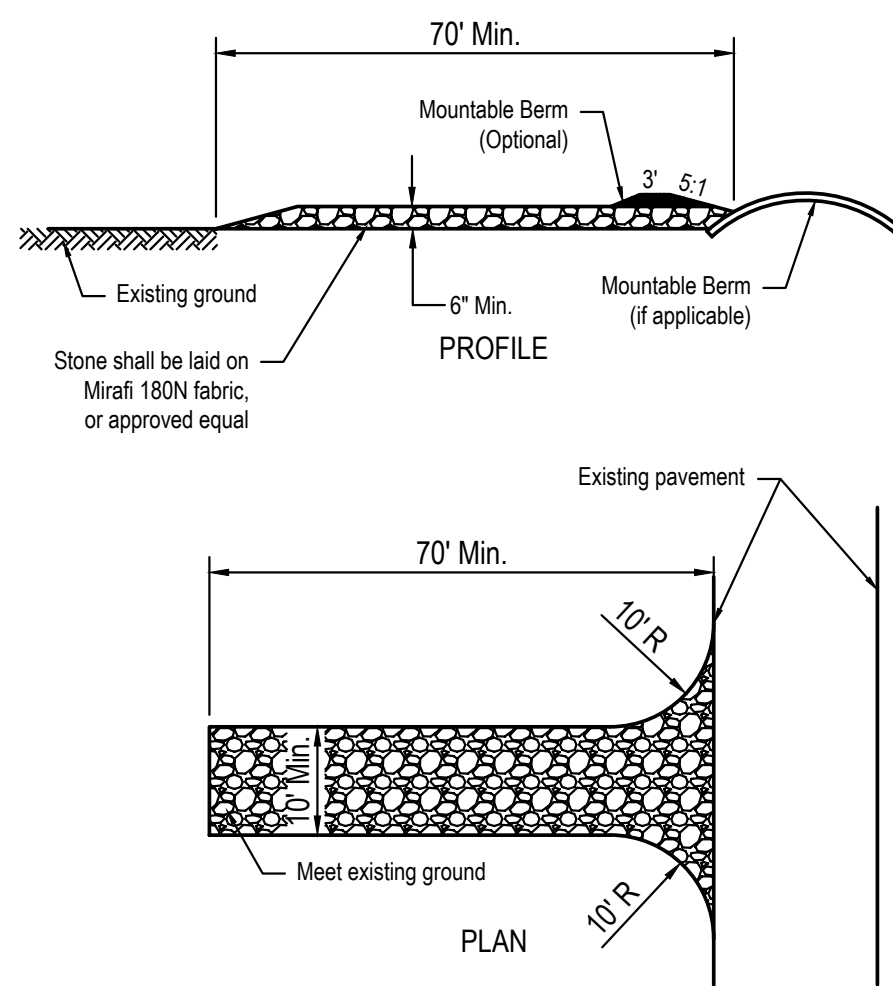

**NOTES**

- The stone size shall be 2" diameter or a reclaimed broken concrete equivalent.
- Contractor shall construct the entrance to a minimum length of 70'.
- The thickness of the stone shall be 6".
- The width of the construction entrance shall be 10' minimum, but in no case less than the full width at points where ingress and egress occur.
- All surface runoff flowing or diverted towards the construction entrance shall be piped across the entrance. If piping is impractical, a mountable berm with 5H:1V will be permitted.
- The entrance shall be maintained in a condition which will prevent tracking or flowing of sediment onto public rights-of-way. This may require periodic top dressing with additional stone as conditions demand and repair and/or cleanout of any measures used to trap sediment. All sediment spilled, dropped, tracked, or washed onto public rights-of-way must be removed immediately.
- Wheels shall be cleaned to remove sediment prior to entrance onto public right-of-way. When washing is required, it shall be done on an area stabilized with stone which drains into an approved sediment trapping device.
- Periodic inspection and needed maintenance shall be provided after each rain.

**STABILIZED CONSTRUCTION ENTRANCE**  
NOT TO SCALE

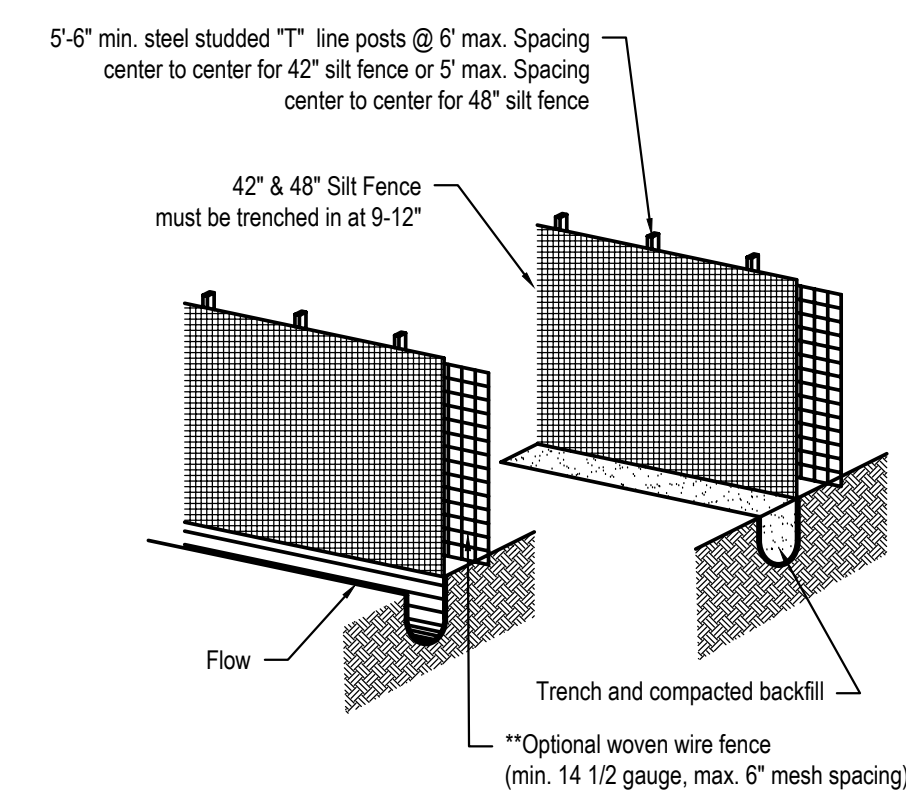

**NOTES:**

- Acceptable silt fence specifications- AOS (#20 - 50 Sieve), Water Flow Rate (50 gpm/ sq. ft. - 125 gpm/ sq. ft.), Tensile Strength (Grab) - (Min. 120 Wap or greater and Elongation (5-25%).
- On each new run of silt fence spray paint the beginning of the run with 0-00 and spray paint the end with the date of installation and LF of the run.
- Silt fence should be securely fastened to each steel support post or to woven wire which is in turn attached to the steel fence posts. A minimum of 3 ties are required for each post. To be located in the top 12" of the silt fence.
- Steel posts which support the silt fence shall be installed on a slight angle toward the anticipated runoff source. (Incline all posts 20° Max. from vertical, toward flow)
- Silt fence shall be trenched in with a silt fence plow so that the downslope face of the trench is flat and perpendicular to the line of flow.
- Silt fence shall be removed when it has served its usefulness so as not to block or impede storm flow or drainage.
- Sediment trapped by this practice shall be uniformly distributed on the source area prior to topsolling.

**SILT FENCE**  
NOT TO SCALE

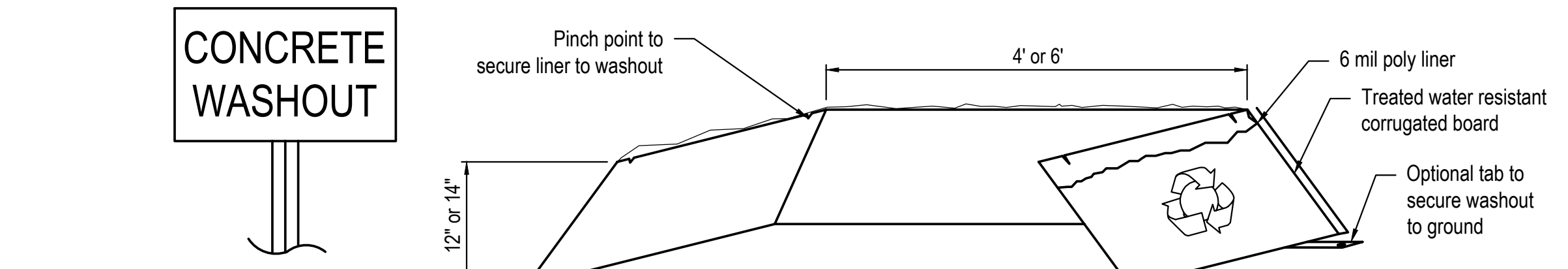

**NOTES:**

- The concrete washout area shall be installed prior to any concrete placement on this project. Install washout area on a level surface. Use Disposable Concrete Washout or approved equal conforming to Section 9.6.8 of the Omaha Regional Stormwater Design Manual.
- Signs shall be placed as necessary to clearly indicate the location of the concrete washout.
- The concrete washout area will be replaced as necessary to maintain capacity for waste concrete and other liquid waste.
- Washout residue shall be removed from the site and disposed of at an approved waste site.
- Do not mix excess amounts of fresh concrete or cement on-site.
- Do not wash out concrete trucks into storm drains, open ditches, streets, or streams.
- Do not dump excess concrete in non-designated dumping areas.
- Locate washout area at least 50' (15 meters) from storm drains, open ditches, or waterbodies.
- Wash out wastes into the Outpack Washout as shown where the concrete can set, be broken up, and then disposed of properly.

**CONCRETE WASHOUT**  
NOT TO SCALE

**E & A CONSULTING GROUP, INC.**  
 Engineering • Planning • Environmental & Field Services  
 10809 Mill Valley Road, Suite 100 • Omaha, NE 68154  
 Phone: 402.895.4700 • Fax: 402.895.3699  
 www.eaeg.com  
 State of NE Certificate of Authorization #C00008

**E & A CONSULTING GROUP, INC.**  
 Engineering Answers

CONTRACTOR BAYS  
 MCGREGOR BRAE - LOTS 2 & 3  
 BENVINGTON, NEBRASKA

SWPPP NOTES

Preliminary  
 Not For Construction  
 10-5-2024

Proj No:	P2015.717.013
Date:	Enter Date
Designed By:	DCW
Drawn By:	E&A
Scale:	AS SHOWN
Sheet:	6 of 12



**Note:**  
To receive final PCSMP approval and / or Certificate of Occupancy, the construction of all PCSMP BMP's are required to be certified by E&A Consulting Group, Inc.. Contractor shall contact Randy Pierce of E&A Consulting Group, Inc. (402-895-4700 office / 402-510-1323 cell) a minimum of 48 hours prior to starting construction on any PCSMP BMP.

**DETENTION BASIN MAINTENANCE TASKS AND SCHEDULE**

Task	Schedule
Remove trash and debris	Monthly
Check and repair any eroded areas	Monthly
Inspect flumes/curb cuts for obstruction, erosion, and undercutting	Monthly
Inspect for erosion and vegetative failure, including overflow path areas and basin backslope	Monthly, reseed as necessary
Inspect for ponding, washed out areas, soil conditions	Monthly
Perimeter mowing	Monthly
Inspect rip-rap at outfall, that it remains in place and is effective	Quarterly, replace as necessary
Inspect embankment for seepage	Quarterly
Weed and remove unwanted vegetation	Semi-annually
Inspect outlet structure and pipes	Annually
Plug animal burrows	Annually
Repair broken pipes	As needed
Remove sediment	As needed

**LEGEND**

- Storm Sewer System
- Sanitary Sewer System
- PCSMP Basin Limits
- Runoff Flow Direction
- Drainage Swale
- Limits of Construction
- Proposed Contours
- Existing Contours
- BMP Identifier
- Limits of Basin Seeding
- Erosion Control Blanket
- Emergency Spillway
- Rip Rap

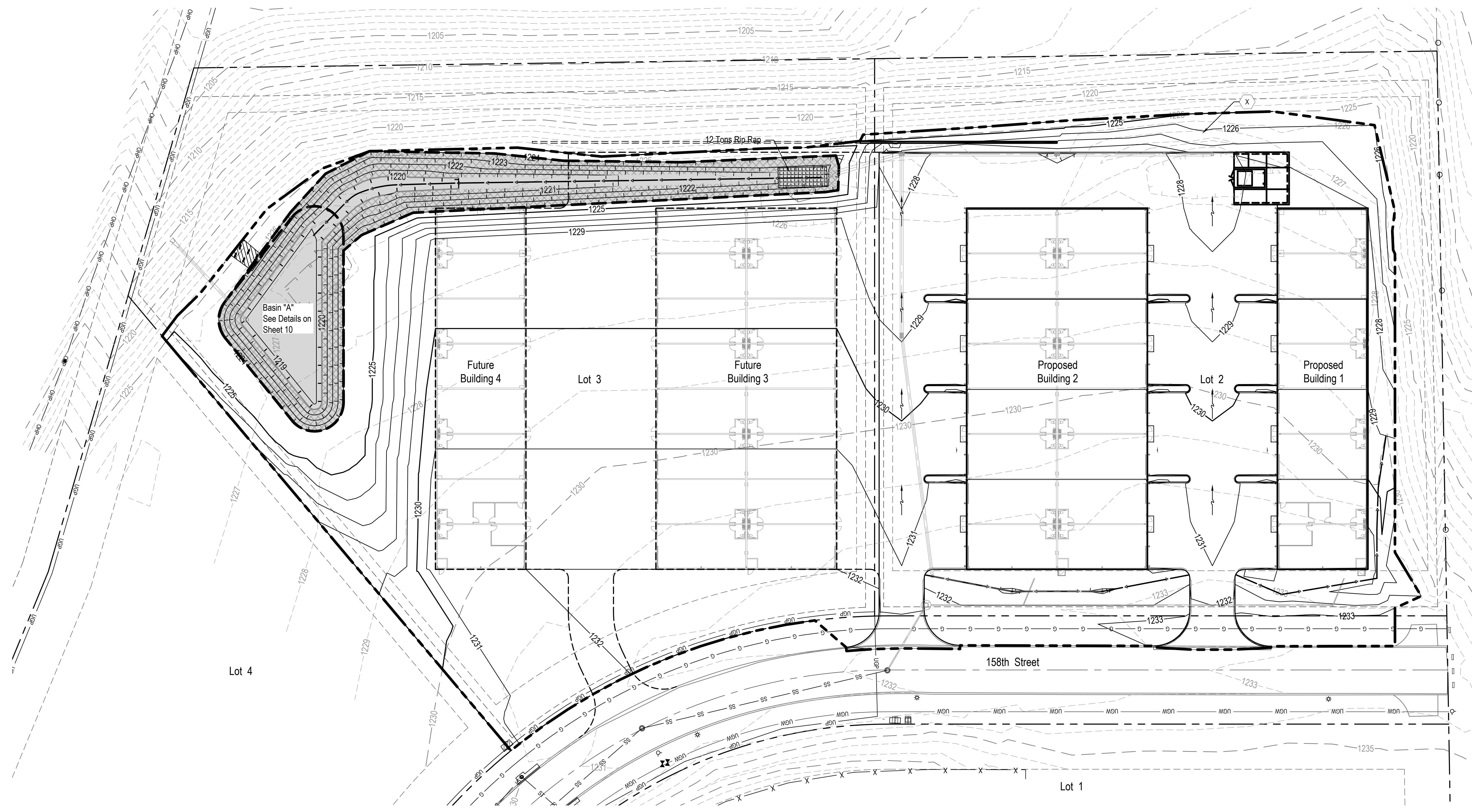
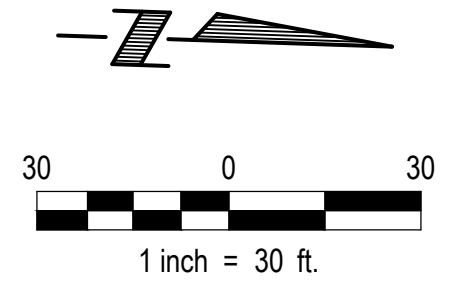

**E & A CONSULTING GROUP, INC.**  
Engineering • Planning • Environmental & Field Services  
10800 Mill Valley Road, Suite 100 • Omaha, NE 68154  
Phone: 402.895.4700 • Fax: 402.895.3999  
www.eaeg.com  
State of NE Certificate of Authorization #C-0008



**CONTRACTOR BAYS**  
MCGREGOR BRAE - LOTS 2 & 3  
BENNINGTON, NEBRASKA

**POST CONSTRUCTION  
STORMWATER  
MANAGEMENT PLAN**

**Preliminary  
Not For Construction  
10-5-2024**

**PCSMP Project No.**

Revisions	Description	Date

Proj No:	P2015.77.013
Date:	10/20/24 12:35 PM
Designed By:	DCW
Drawn By:	E&A
Scale:	AS SHOWN
Sheet:	9 of 12

See Details  
10/20/24 12:35 PM K:\Projects\2015\77\PCSMP\Engineering\CAD\Sheet09.dwg PCSMP-009.dwg



Note:  
To receive final PCSMP approval and / or Certificate of Occupancy, the construction of all PCSMP BMP's are required to be certified by E&A Consulting Group, Inc.. Contractor shall contact Randy Pierce of E&A Consulting Group, Inc. (402-895-4700 office / 402-510-1323 cell) a minimum of 48 hours prior to starting construction on any PCSMP BMP.

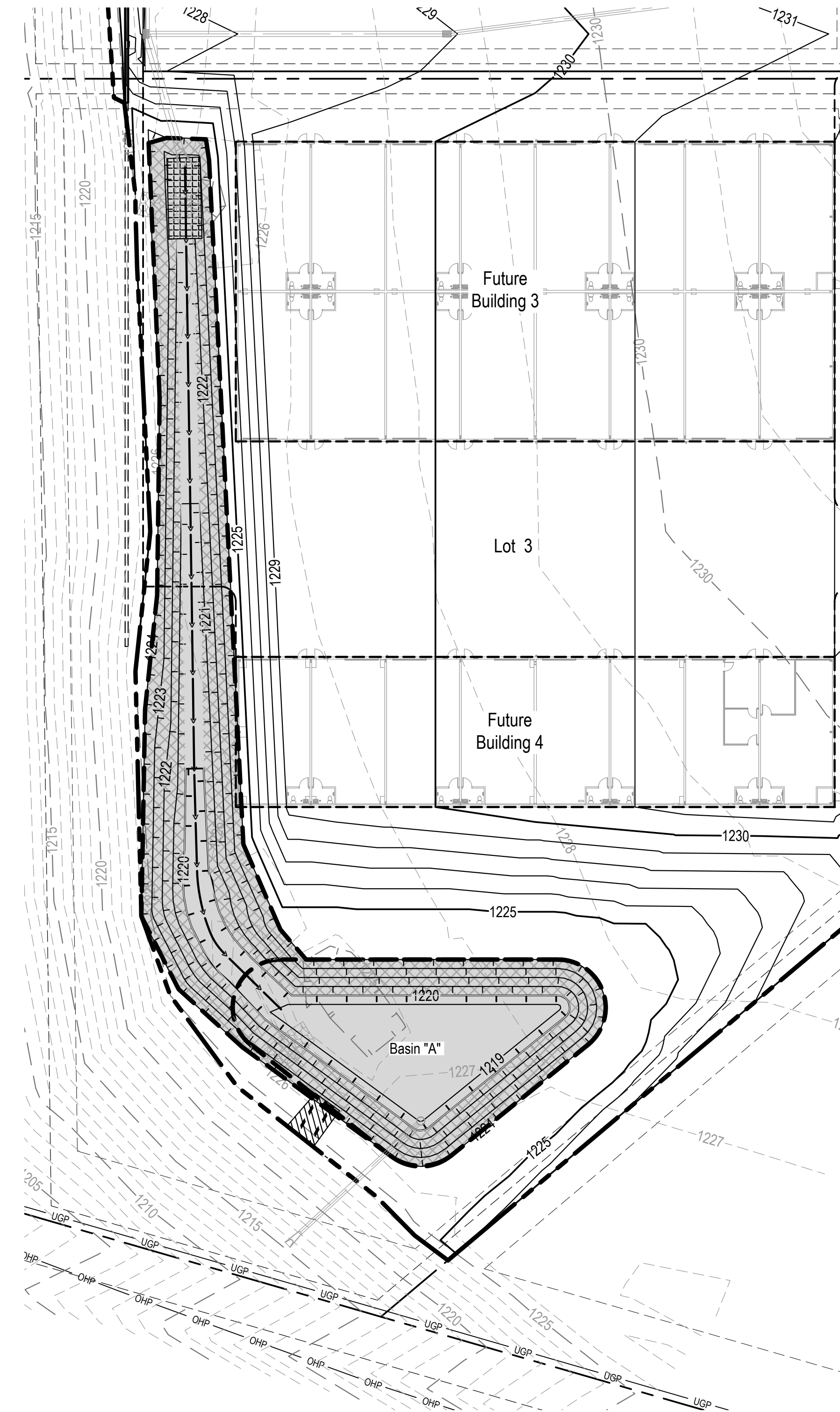

**BASIN "A" DETAIL**  
1" = 30'

**TRANSITION MAT GENERAL NOTES**

- Transition Mat shall be Flexamat with Curlex II Underlayment, or approved equal. Flexamat is available from A.S.P. Enterprises (Attn: Brian Williams) Omaha, NE, 402-861-8579
- Erosion Control Mat shall be installed per manufacturers recommendations

**DETENTION BASIN MAINTENANCE TASKS AND SCHEDULE**

Task	Schedule
Remove trash and debris	Monthly
Check and repair any eroded areas	Monthly
Inspect flumes/curb cuts for obstruction, erosion, and undercutting	Monthly
Inspect for erosion and vegetative failure, including overflow path areas and basin backslope	Monthly, reseed as necessary
Inspect for ponding, washed out areas, soil conditions	Monthly
Perimeter mowing	Monthly
Inspect rip-rap at outfall, that it remains in place and is effective	Quarterly, replace as necessary
Inspect embankment for seepage	Quarterly
Weed and remove unwanted vegetation	Semi-annually
Inspect outlet structure and pipes	Annually
Plug animal burrows	Annually
Repair broken pipes	As needed
Remove sediment	As needed

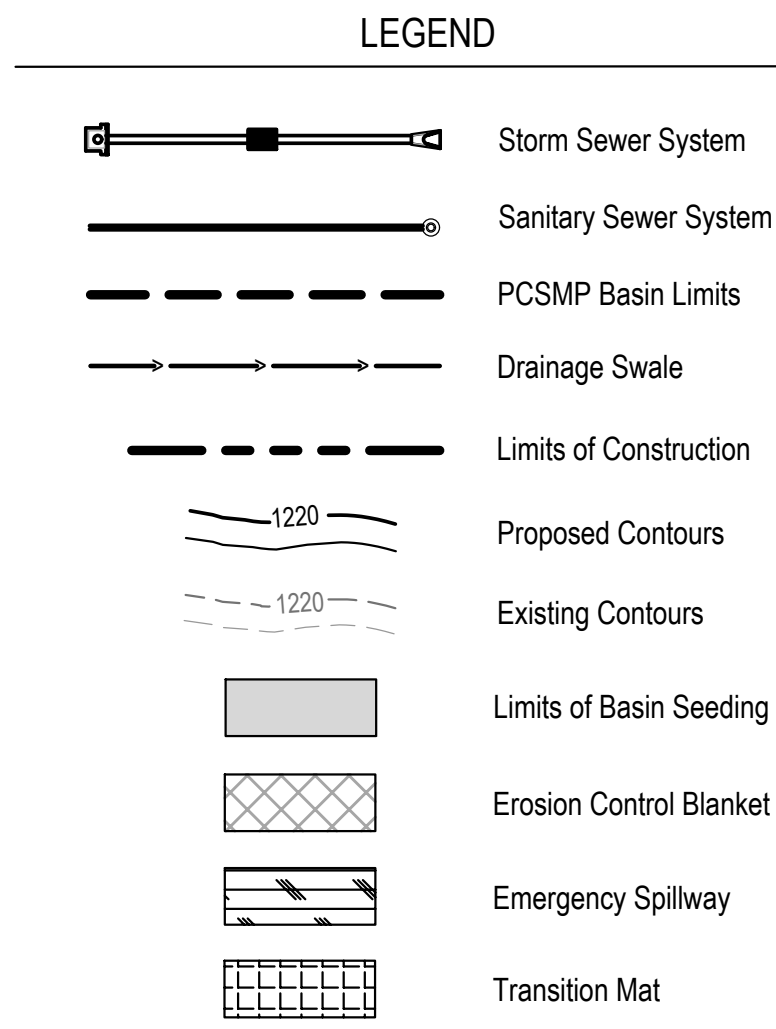

netcall.com  
**Nebraska 811**  
know what's below.  
Call before you dig.  
Dial: 811

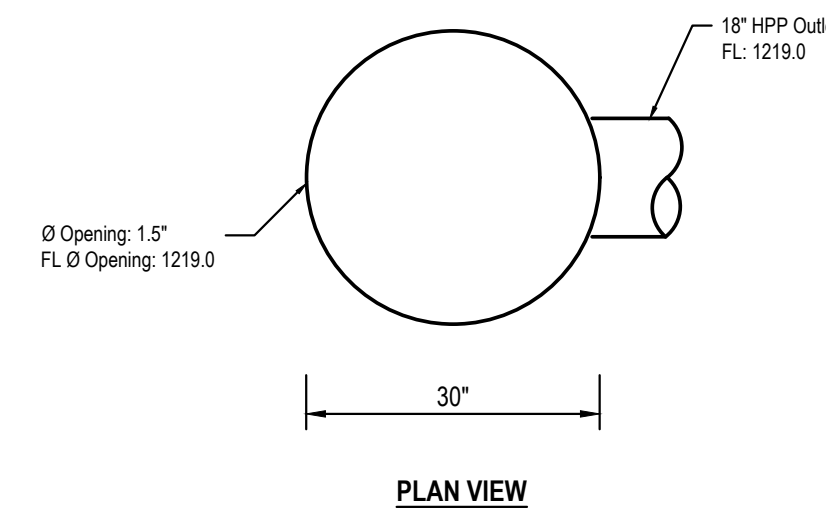
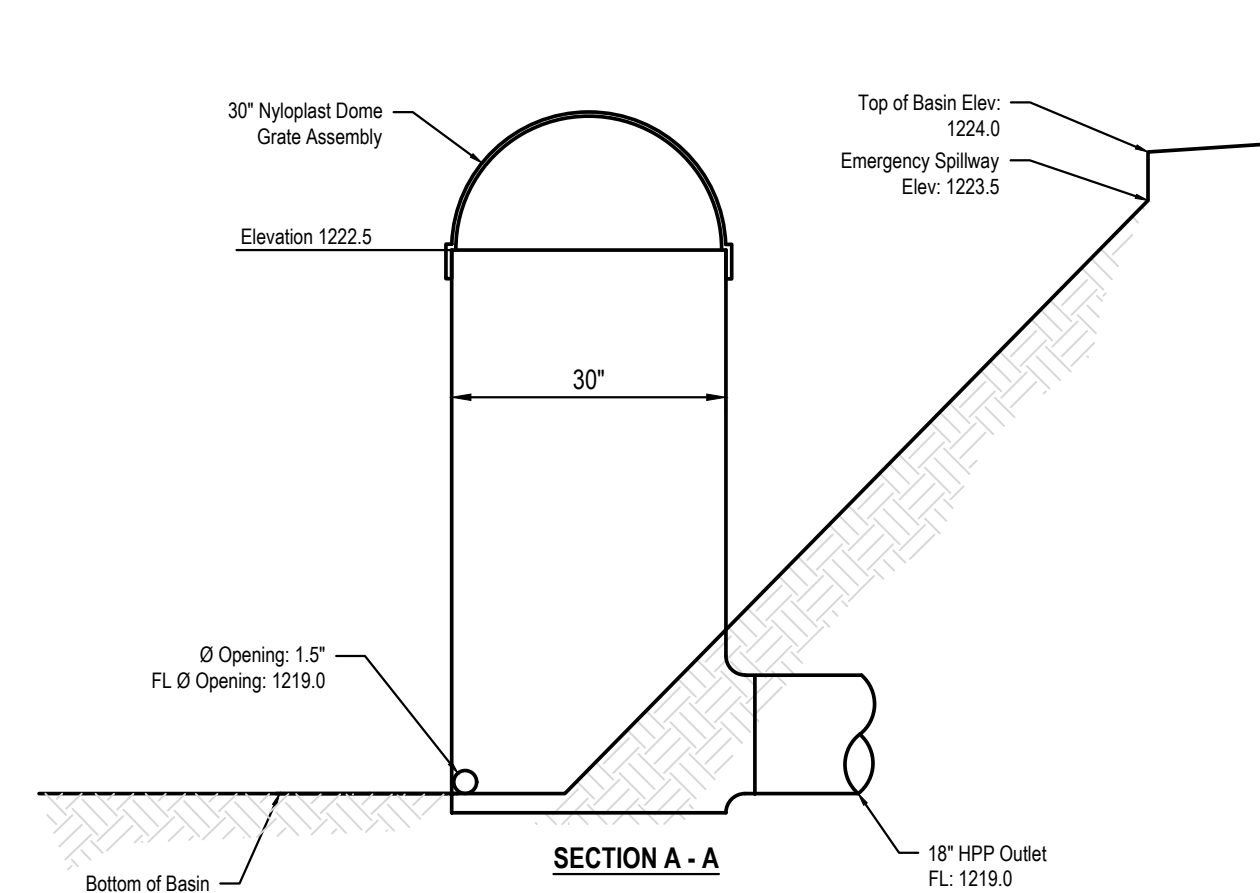
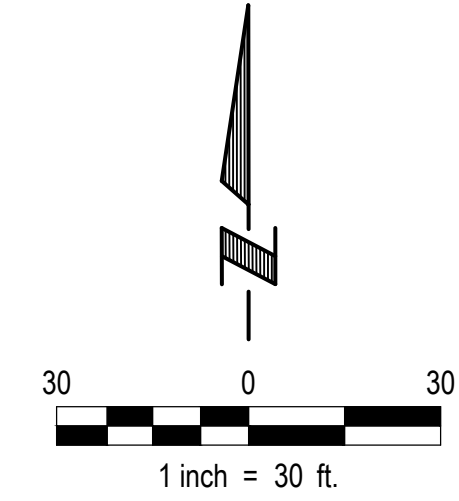

**DRY DETENTION NYLOPLAST BASIN OUTLET**  
NOT TO SCALE

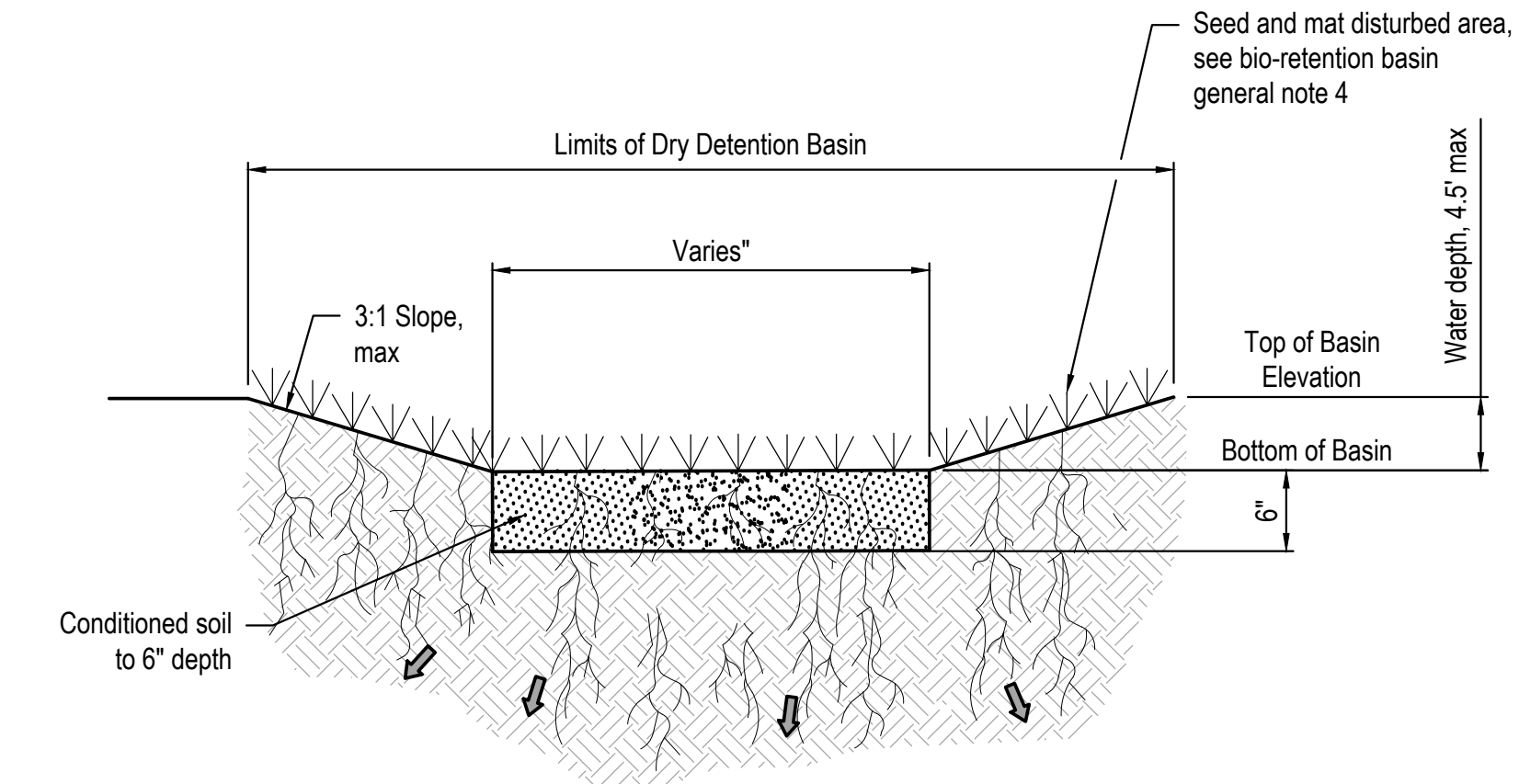

**DRY DETENTION BASIN DETAIL**  
NOT TO SCALE

**DETENTION BASIN GENERAL NOTES**

- The contractor shall work to minimize compaction by limiting construction traffic and equipment size within the limits of the basin.
- Seeding shall be Superturf II no rye (sod grower) lateral spread tall fescue kentucky bluegrass mixture from United Seeds, Inc. Planting method and seeding rate shall be 10 lbs per 1,000 sq ft. Seeding dates: March-June, dormant seeding: December - March.
- Erosion control blanket shall be installed on the basin side slopes. Erosion control blanket shall be North American Green S-75, or approved equal, installed per manufacturer's recommendation.
- Conditioned soil: incorporate 1"-2" of Omgrow compost in upper 6" of the basin bottom by means of a tiller.

BASIN A AND RISER INFORMATION																
BASIN	BOTTOM ELEV.	TOP ELEV.	EMERGENCY SPILLWAY		STRUCTURE TYPE (R1)	STRUCTURE DIAMETER	RIM ELEVATION	ON-SITE DRAINAGE AREA (AC)	OFF-SITE DRAINAGE AREA (AC)	1/2" WATERSHED VOLUME		HOLE DIAMETER (QTY)	HOLE ELEVATION	HPP OUTLET PIPE (ST9)		
			ELEVATION	WIDTH						REQUIRED (CF)	PROVIDED (CF)			DIAMETER	INVERT ELEVATION	
A	1219.00	1224.00	1223.50	10'	Nyloplast Basin	30"	1222.50	3.51	0.00	6,370	11,274	1.5" (1)	1219.00	DRY	18"	1219.00

**E & A CONSULTING GROUP, INC.**  
Engineering • Planning • Environmental & Field Services  
10809 Mill Valley Road, Suite 100 • Omaha, NE 68154  
Phone: 402-895-4700 • Fax: 402-895-3699  
www.eaeg.com  
State of NE Certificate of Authorization #C-00008



CONTRACTOR BAYS  
MCGREGOR BRAE - LOTS 2 & 3  
BENNINGTON, NEBRASKA

POST CONSTRUCTION  
STORMWATER  
MANAGEMENT PLAN

Preliminary  
Not For Construction  
10-5-2024

Revisions	Description	Date

Proj No: P2015.77.013  
Date: Enter Date  
Designed By: DCW  
Drawn By: E&A  
Scale: AS SHOWN  
Sheet: 10 of 12

PCSMP Project No.



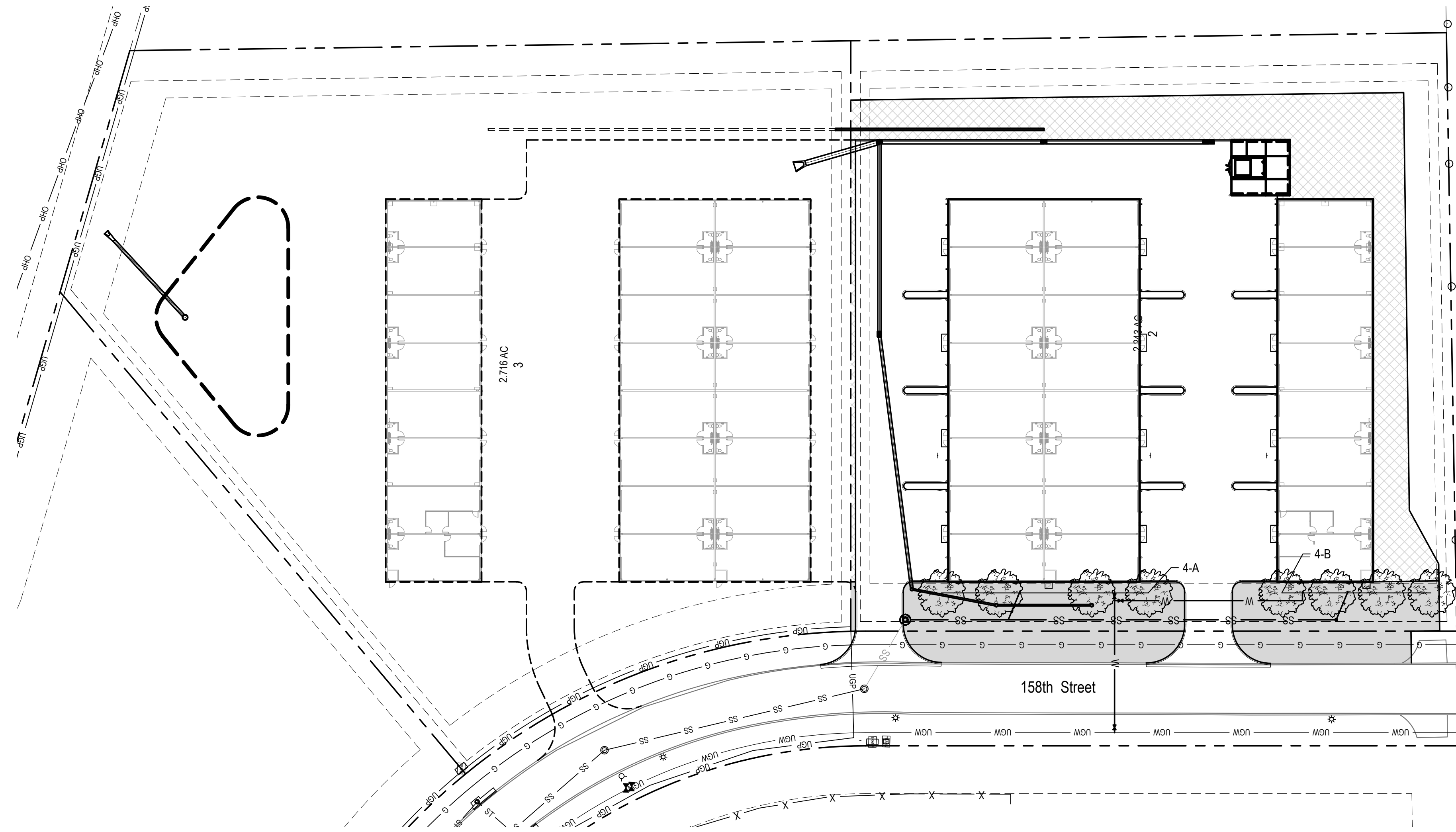

### PLANT SCHEDULE

SYM	QTY	BOTANICAL NAME	COMMON NAME	SIZE	TYPE
A	4	Acer x freemanii Celebration	Celebration Maple	2"	B&B
B	4	Gleditsia triacanthos 'Skyline'	Skyline Honeylocust	2"	B&B

**TREE NOTE:**  
 Landscape contractor must coordinate with all utilities and general contractor to field verify all utility locations that may conflict with all proposed tree planting locations on the project site.

- LEGEND:**
- [Solid Grey Box] - Areas to be installed with sod & irrigation. To be determined by Owner.
  - [Cross-hatched Box] - Areas to be installed with seed & matting. To be determined by Owner.

#### Section 7.09: Landscape Requirements and Fence and Retaining Wall Regulations

7.09.01 (B)(iv) A minimum of one tree, of a minimum of two-inch caliper, shall be planted for every 40 lineal feet or fraction thereof.  
 Required = 8 trees Provided = 8 trees

7.09.01 (F)(i) Off-street parking lots, as defined in 7.09.01 (E), and other vehicular use areas shall have at least (5) percent of the total area utilized for parking space excluding those spaces abutting a perimeter for which landscaping is required by other sections of this Ordinance and excluding all parking spaces which are directly served by an aisle abutting and running parallel to such perimeter.  
 Required = 1,594 SF (5% of 31,873 SF) Provided = 2,520 SF

#### LANDSCAPE NOTES:

- Locate and verify the location of all underground utilities prior to the start of any construction. Care should be taken not to disturb any existing utilities during construction. Any damage to utilities or other improvements caused by the Contractor will be repaired at no cost to the Owner.
- All plant material shall be of good quality and sizes shall meet required size specifications.
- All plants are to be watered in immediately after planting and then watered once a week for a period of two months from time of planting.
- All plant material shall be guaranteed to be in a live and healthy growing condition for two full growing seasons (trees) and one full growing season (perennials & shrubs) after final project acceptance or shall be replaced free of charge with the same grade and species including labor.
- Verify all dimensions and conditions prior to starting construction. The location of plant material is critical and shall be installed as indicated on plans. Field adjustments may be necessary based on field conditions (i.e., root ball and drop inlet conflict). All adjustments must be approved by the landscape architect.
- The Landscape Contractor shall remove all construction debris and materials injurious to plant growth from planting pits and beds prior to backfilling with planting mix. All planting areas shall be free of weeds and debris prior to any work.
- Provide locally available shredded hardwood mulch on all trees and in all planting beds to a 3-4 inch minimum depth unless otherwise noted. Mulch ring to extend 1'-0" minimum beyond planting pit. Minor site grading to be included if needed.
- All trees are to be staked for a period of not less than one year from time of planting.
- Contractor to coordinate work with other amenities contractors.

#### IRRIGATION NOTES:

- Irrigation bid to include meter pit and city utility fees.
- Irrigate all sodded areas.
- Irrigation controller to be mounted in a steel utility box with hasp for pad lock.
- Irrigation system to be guaranteed for 1 year. Written guarantee to be supplied prior to final payment.
- Irrigation contractor responsible to winterize system one time.
- Irrigation contractor to furnish as built drawing of the system and catalogue cuts of the installed equipment prior to final payment.
- Contractor to coordinate work with other amenities contractors.

#### SODDING NOTES:

- The contractor shall notify the architect at least forty-eight hours in advance of the time he intends to begin sodding and shall not proceed with such work until permission to do so have been granted. No frozen sod shall be placed. No sodding shall be done on frozen earth.
- Care shall be exercised at all times to retain the native soil on the roots of the sod during the process of transplanting. Dumping from vehicles will not be permitted. The sod shall be planted within eighteen (18) hours from the time it is harvested unless it is tightly rolled or stored roots-to-roots in a satisfactory manner. All sod in stacks shall be kept moist and shall be protected from exposure to the sun and from freezing. No storage longer than three (3) days will be permitted. Sod which becomes dried out or does not meet the specifications will be rejected.
- There shall be a minimum of six inches, after tamping, of topsoil under all sod. Excavations or trenching shall be made to a sufficient depth below the finished grade of the sod to accommodate the depth of topsoil as specified and the thickness of sod as specified. Fertilizer shall be applied at a rate to provide 100 pounds of nitrogen per acre unless fertilizer has been applied under another item in this contract to the topsoil in the sod bed. Fertilizer applied under this item shall be incorporated with the topsoil to a depth of at least two inches before the sod is laid, unless otherwise specified or approved. Incorporation shall be accomplished by disking, harrowing, drilling, raking or other approved means.
- The soil on which the sod is laid shall be reasonably moist and shall be watered, if so directed. The sod shall be laid smoothly, edge to edge, and all openings shall be plugged with sod. Immediately after the sod is laid, it shall be pressed firmly into contact with the sod bed by tamping, rolling, or by other approved methods so as to eliminate all air pockets, provide true and even surfaces, insure knitting and protect all exposed sod edges but without displacement of the sod or deformation of the surface of the sodded areas and watered at the rate of five gallons per square yard of sodded area unless otherwise directed.
- The contractor shall take care of the sodded areas until all work on the entire contract has been completed, and sod has been mowed twice and then accepted. Such care shall consist of providing protection against traffic by approved warning signs or barricades and the mowing of grass to the height of two inches when the growth attains a maximum height of four inches.
- Sod shall also be watered. When the sod is watered, sufficient water shall be applied to wet the sod at least two inches deep in the sod bed. Watering shall be done in a manner which will not cause erosion or other damage to the finished surfaces. Any surfaces which become gullied or otherwise damaged shall be repaired to reestablish the grade and conditions of the soil prior to sodding and shall then be re-fertilized and re-sodded as specified under this item.
- In drainage-ways or slopes, the sod shall be laid with their longest dimensions parallel to the contours. Such sodding shall begin at the base of slopes or grades and the sodding progress in continuous parallel rows working upward. Vertical joints between such sodding shall be staggered. All sod shall be laid to the grades specified and the grades formed with special care at the junction of drainage-ways.
- Sod shall be held in place by stakes in all drainage-ways, on all slopes steeper than 4:1 and elsewhere where specified or as directed. Pegging shall be done immediately after tamping. At least one stake shall be driven through each sod to be staked, and the stakes shall not be more than two feet apart. Stakes shall have their flat sides against the slope and be driven flush. Stakes for pegging sod shall be of wood, approximately one inch by two inches and of sufficient length to penetrate the sod, the topsoil and to a minimum depth of two inches of subsoil.
- The contractor shall keep all sodded areas thoroughly watered for a period of thirty (30) calendar days after the initial laying and as often as required thereafter until sod has been fully established (two mowings) and accepted by the engineer and owner. Contractor to use temporary irrigation for the watering of the sod. Contractor to supply all necessary hoses, fittings and sprinklers for all watering needs.
- All sod must be fully established (two mowings) and growing at the time of inspection and acceptance.

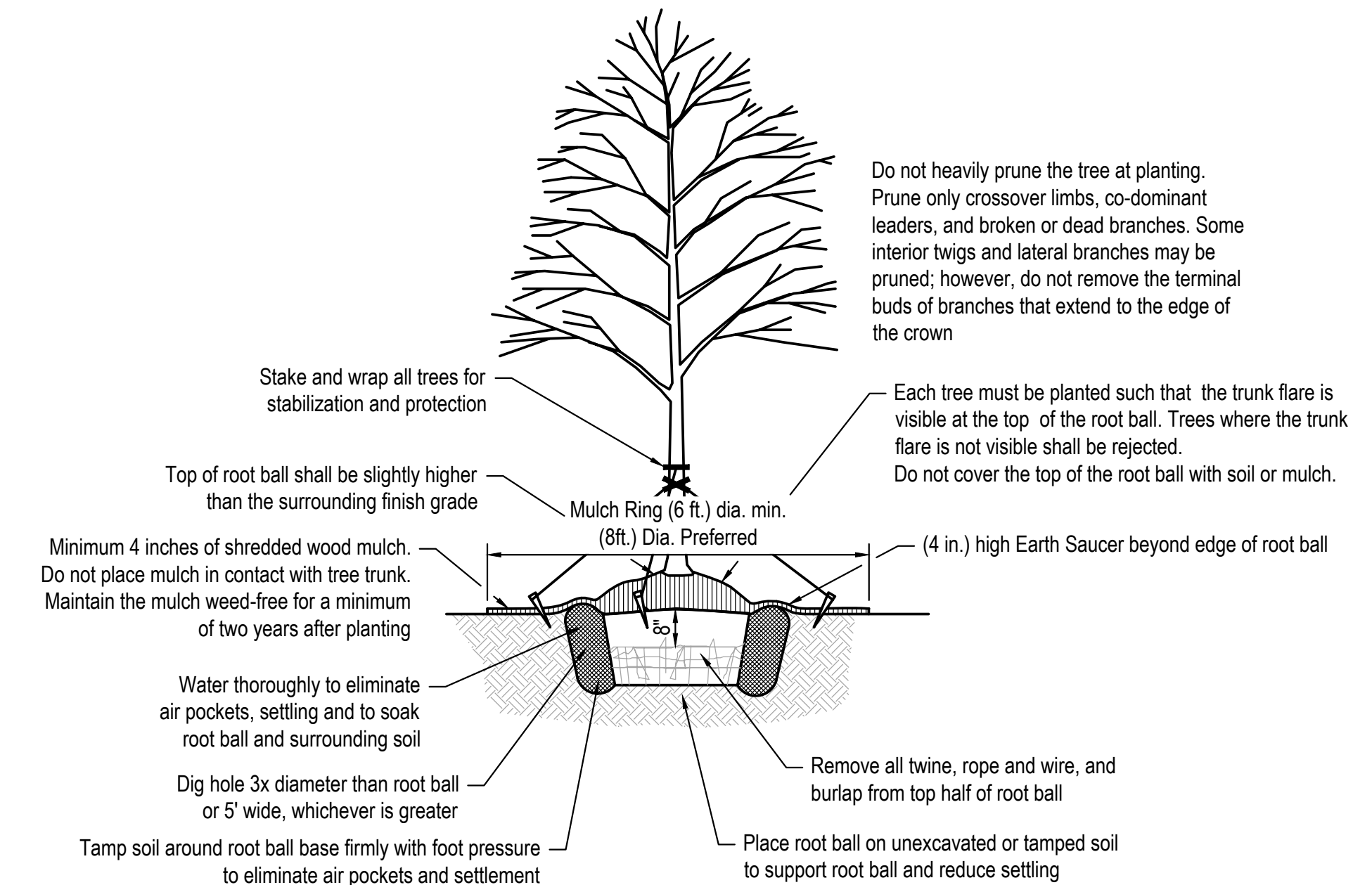

**TREE PLANTING DETAIL - B & B TREE**  
 NOT TO SCALE

#### SEEDING NOTES:

- Seeding shall be Superturf II no rye (sod grower) lateral spread tall fescue kentucky bluegrass mixture from United Seeds, Inc. Planting method and seeding rate shall be 10 lbs per 1,000 sq ft. Seeding dates: March-June, dormant seeding: December-March.
- Matting shall be installed over all seeding areas (S75 - NAG Single Net Straw Matting OR EQUIVALENT).
- Contractor to coordinate work with other amenities contractors.



CONTRACTOR BAYS  
 MCGREGOR BRAE - LOTS 2 & 3  
 BENVINGTON, NEBRASKA

LANDSCAPE PLAN

Preliminary  
 Not For Construction  
 10-5-2024

Revisions	Date	Description

Proj No: P2015.7.7.013  
 Date: Enter Date  
 Drawn By: DCW  
 Scale: AS SHOWN  
 Sheet: 11 of 12



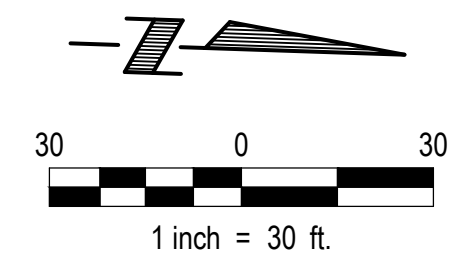

**LEGEND**

- Fire Department Access Route
- DE = Dead End Length of Fire Department Access Route
- HP = Hose Pull Distance from Fire Department Access Route
- DD = Door Distance from Fire Department Access Route
- FH = Fire Hydrant Distance

**NOTES**

- 1 Paved areas within the project that are not shaded are not a Fire Department Access Route and are not subject to Fire Department requirements.
- 2 Distances shown are the distances a portion of a building is from a fire hydrant or a Fire Department Access Route.
- 3 Intersection pavement radii along the Fire Department Access Route are labeled.

**FIRE ACCESS AND COVERAGE NOTES**

- 1 Existing M.U.D. Fire Hydrant

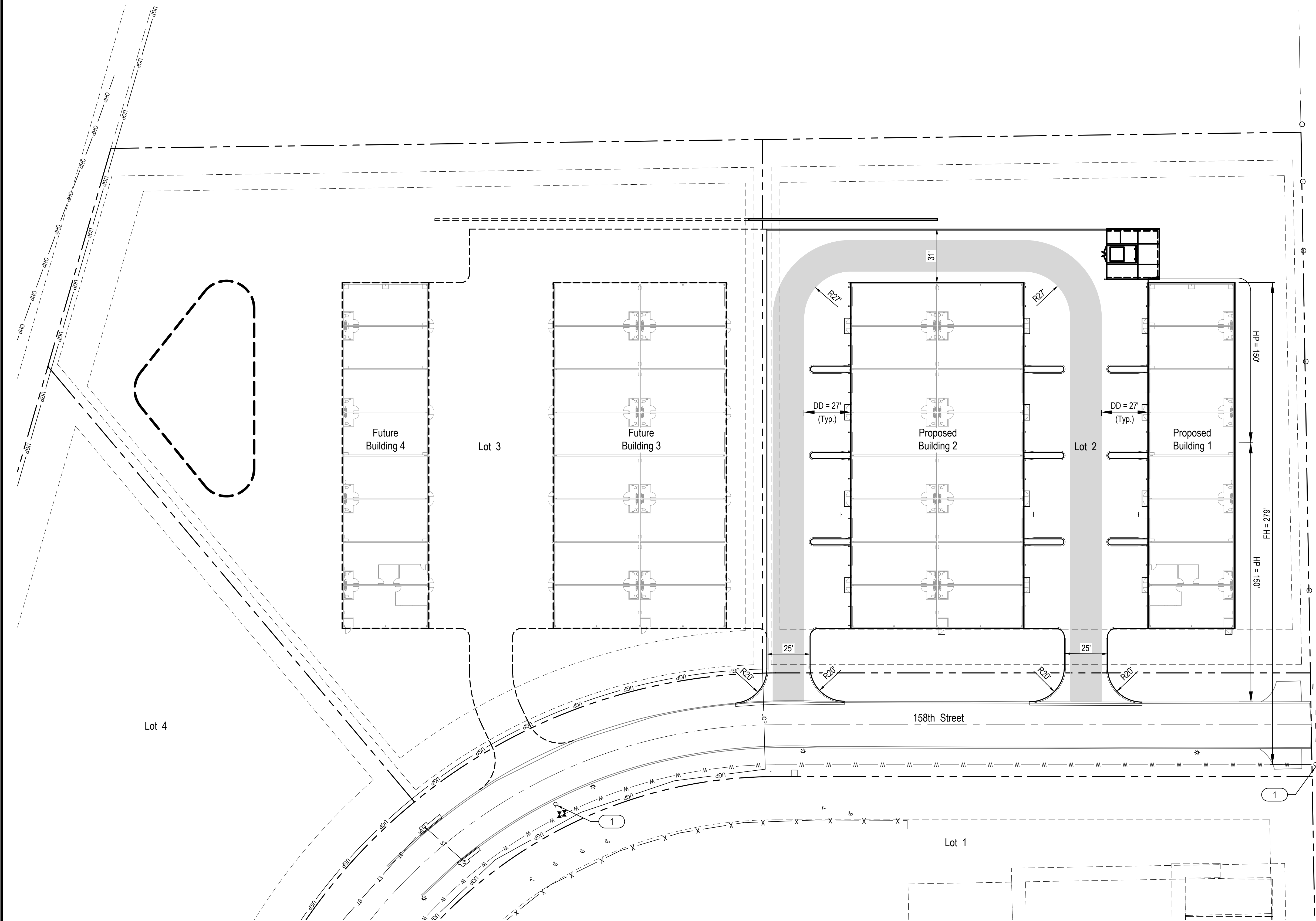

**CONTRACTOR BAYS**  
 MCGREGOR BRAE - LOTS 2 & 3  
 BENVINGTON, NEBRASKA

**FIRE ACCESS AND COVERAGE PLAN**

**Preliminary  
 Not For Construction  
 10-5-2024**

Proj No.	Date	Enter Date	DCW	ESG	AS SHOWN
P2015.77.013					
Designed By:					
Drawn By:					
Scale:					
Sheet:	12	of	12		

10/20/24 12:35 PM K:\Projects\2015\77\1015\Engineering\CAD\1015\12\Fire Access.dwg



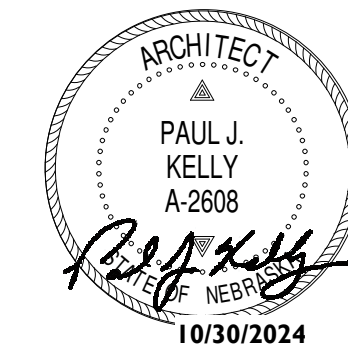

11/6/2024 7:49:20 PM

BLDG A PLAN & DETAILS

REVISIONS

No.	Description	Date
1	ADDENDUM NO. 1	11/6/24

# Contractor Storage Bays

McGregor Interests  
PIN 1729720452, Bennington, NE 68007

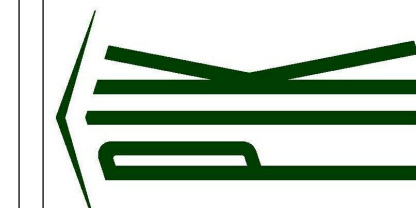

Paul J. Kelly  
Architecture  
440 North 61st Street  
Omaha, Nebraska 68132  
(402) 320-4131  
pjarchitecture.com

# A.I.A.

Project No. 24-021-01  
Date 30 October 2024

Print on 27" x 34" format for proper scale

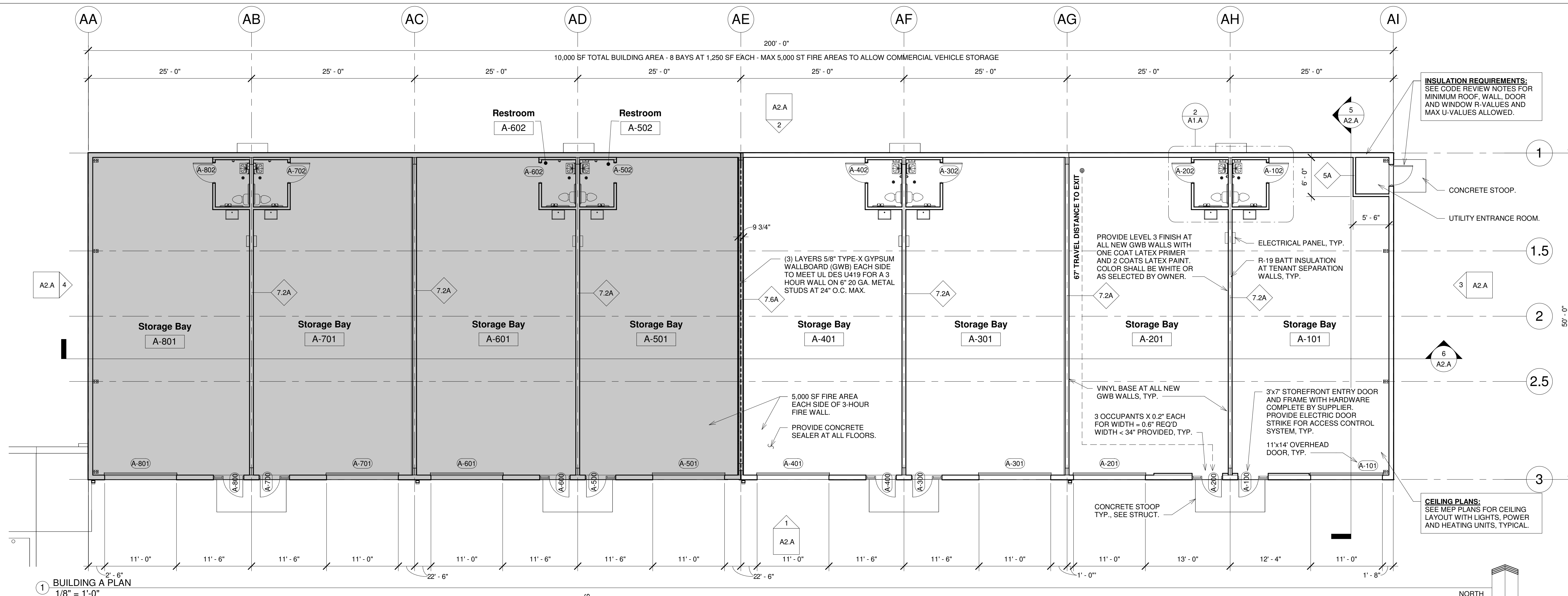

1 BUILDING A PLAN  
1/8" = 1'-0"

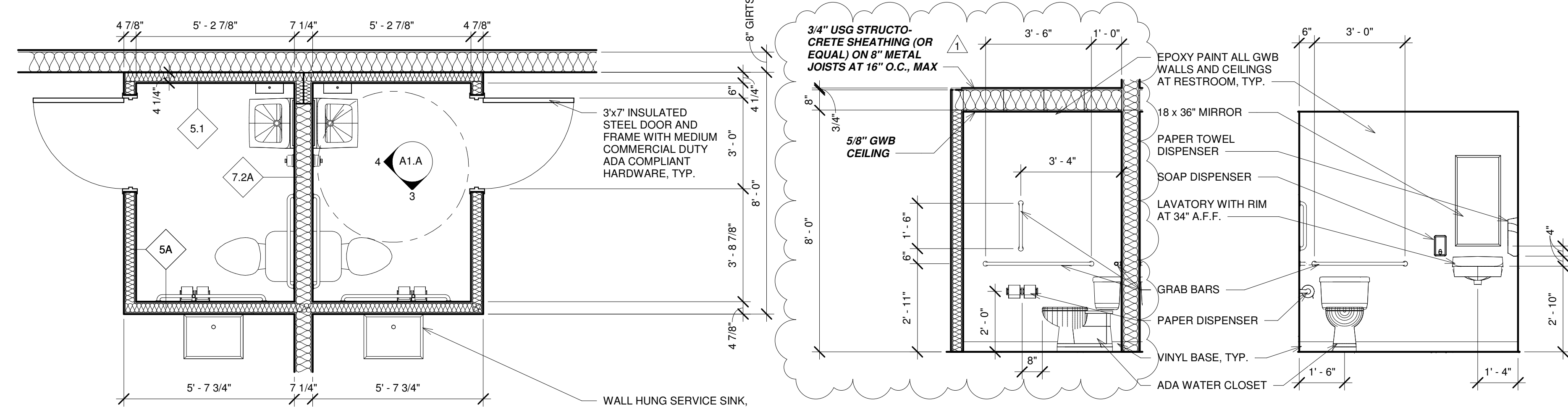

2 RESTROOM PLAN  
3/8" = 1'-0"

3 RESTROOM - SIDE WALL  
3/8" = 1'-0"

4 RESTROOM - WET WALL  
3/8" = 1'-0"

- GENERAL FLOOR PLAN NOTES**
- ALL SERVICES SHALL BE KEPT INTO CONTINUOUS OPERATION UNLESS PERMISSION IS GRANTED BY OWNER.
  - ITEMS SHOWN LIGHT/HALF-TONED INDICATE EXISTING WORK TO REMAIN. ITEMS SHOWN BOLD/FULL-TONED INDICATES NEW OR MODIFIED WORK.
  - ALL INTERIOR WALLS SHALL BE TYPE-5 UNLESS NOTED OTHERWISE. SEE WALL TYPES.
  - PROVIDE BACKING AT ALL LOCATIONS WHERE EQUIPMENT IS SHOWN OR NOTED.
  - ALL DIMENSIONS ARE TO FINISH WALL SURFACE UNLESS NOTED OTHERWISE.
  - REFER TO ROOM FINISH SCHEDULE AND FINISH LEGEND FOR NEW FINISHES. REMOVE, CLEAN, PATCH/REPAIR EXISTING SURFACES AND FINISHES AS NECESSARY FOR THE INSTALLATION OF NEWLY SCHEDULED FINISHES.
  - EXISTING STRUCTURAL SYSTEM SHALL NOT BE REMOVED OR MODIFIED UNLESS APPROVED IN ADVANCE BY THE ARCHITECT. MODIFICATIONS TO THE FIRE PROTECTION AND FIRE RESISTIVE WALL OR FLOOR SYSTEMS SHALL BE RESTORED TO MAINTAIN THE REQUIRED RATING.
  - AREAS OF THE BUILDING SHALL REMAIN OCCUPIED DURING CONSTRUCTION. COORDINATE AND PROVIDE TEMPORARY INSTALLATIONS AND ENCLOSURES AS NECESSARY TO SEPARATE/PROTECT THE OCCUPIED AREAS FROM DEMOLITION AND CONSTRUCTION ACTIVITIES.
  - PREP EXISTING FLOOR SURFACE AS NECESSARY FOR NEWLY SCHEDULED FINISHES. PROVIDE SELF-LEVELING CONCRETE FLOOR UNDERLAYMENT AS REQUIRED TO ACHIEVE A SMOOTH, LEVEL SUBSTRATE FOR FLOOR FINISHES.
  - FIELD VERIFY DIMENSIONS. LAYOUT ENTIRE AREA WITHIN CONFINES OF EXISTING CONSTRUCTION AND RESOLVE DISCREPANCIES PRIOR TO INSTALLATION OF ANY WALLS.

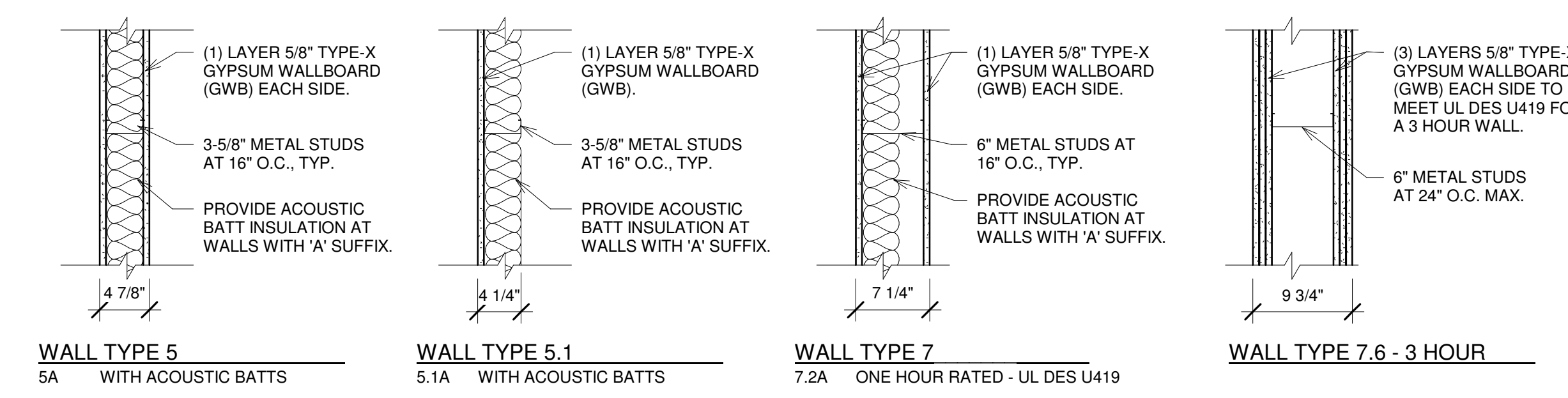

7 WALL TYPES  
1" = 1'-0"



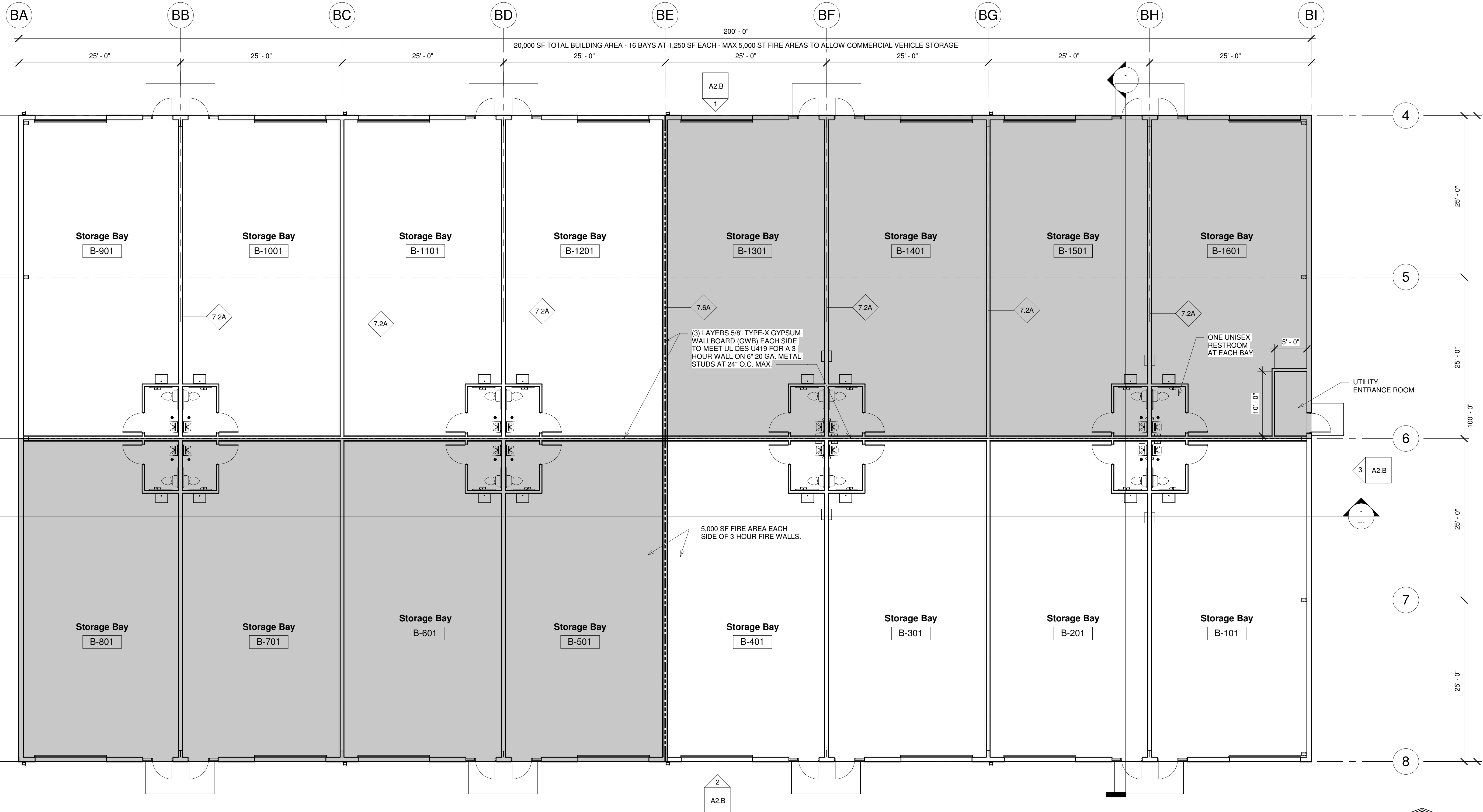

1 BUILDING B PLAN  
1/8" = 1'-0"

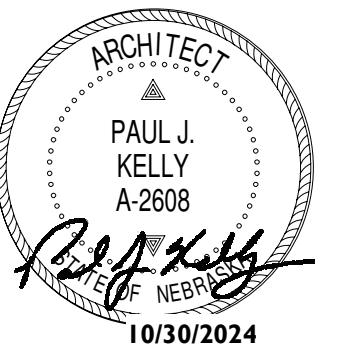

**BLDG B PLAN & DETAILS**

REVISIONS		Date
No.	Description	

**Contractor Storage Bays**  
 McGregor Interests  
 PIN 1729720452, Bennington, NE 68007

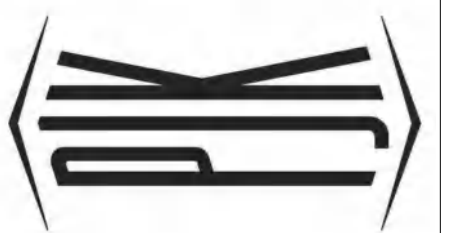

**Paul J. Kelly**  
 Architecture  
 440 North 61st Street  
 Omaha, Nebraska 68132  
 (402) 320-4131  
 pjarchitecture.com

**A.I.B.**  
 Project No. 24-021-01  
 Date 30 October 2024



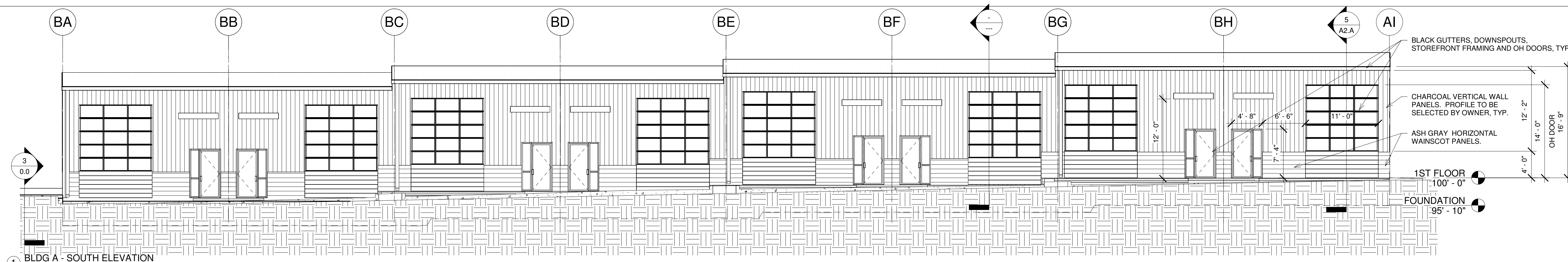

1 BLDG A - SOUTH ELEVATION  
1/8" = 1'-0"

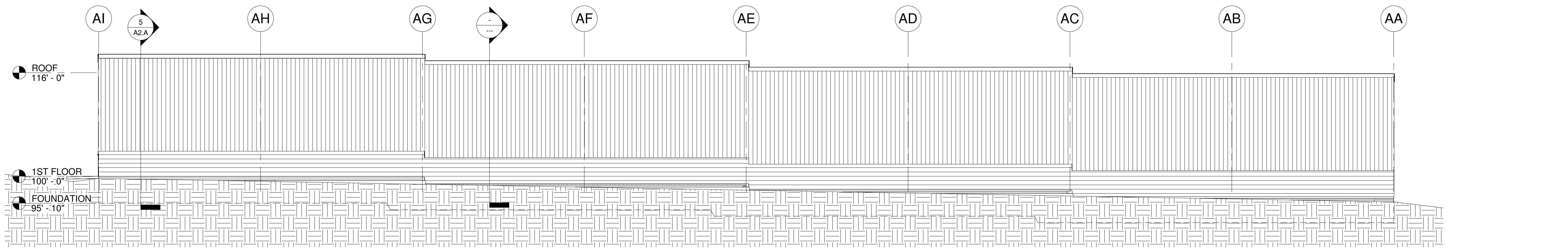

2 BLDG A - NORTH ELEVATION  
1/8" = 1'-0"

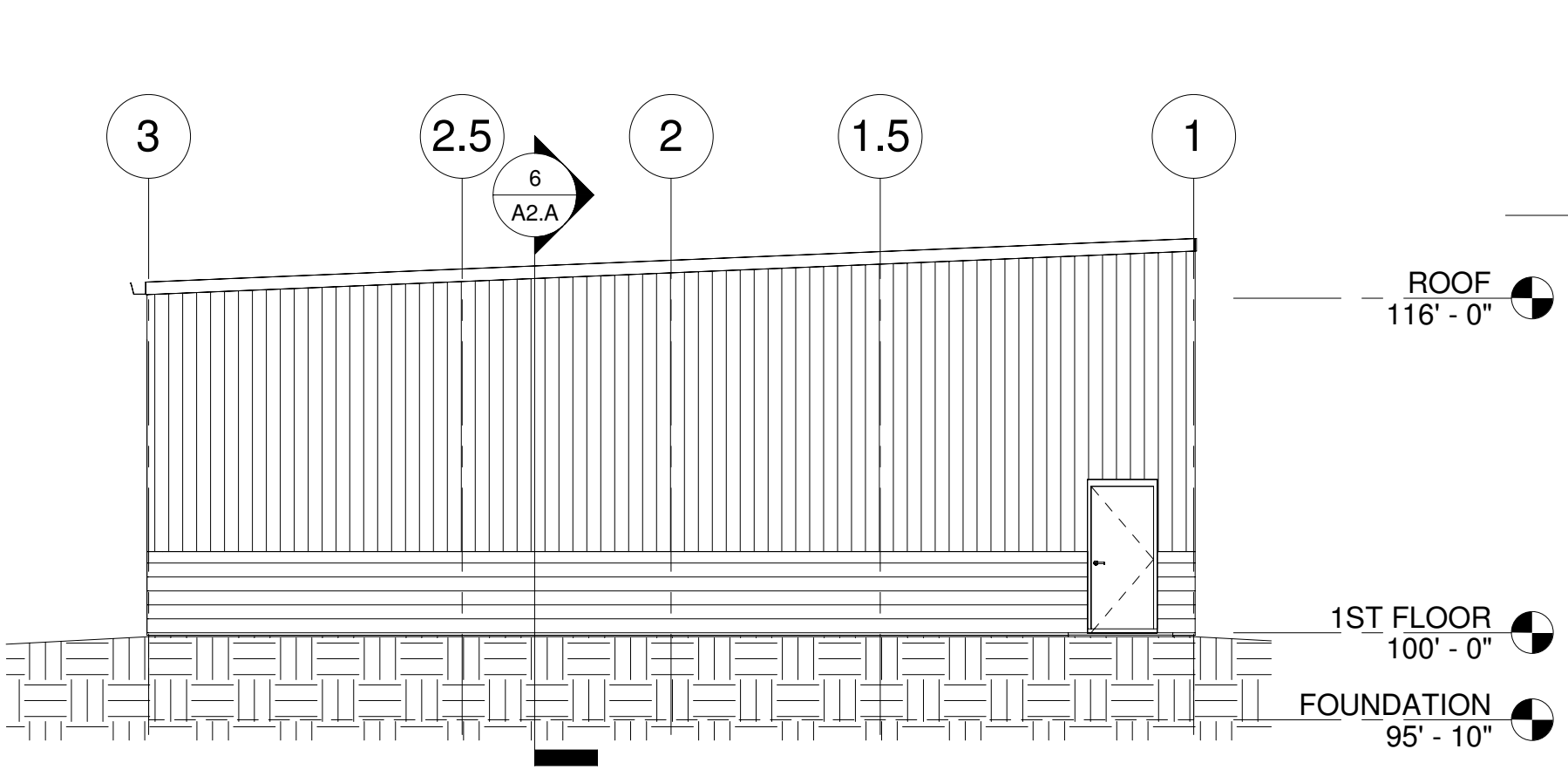

3 BLDG A - EAST ELEVATION  
1/8" = 1'-0"

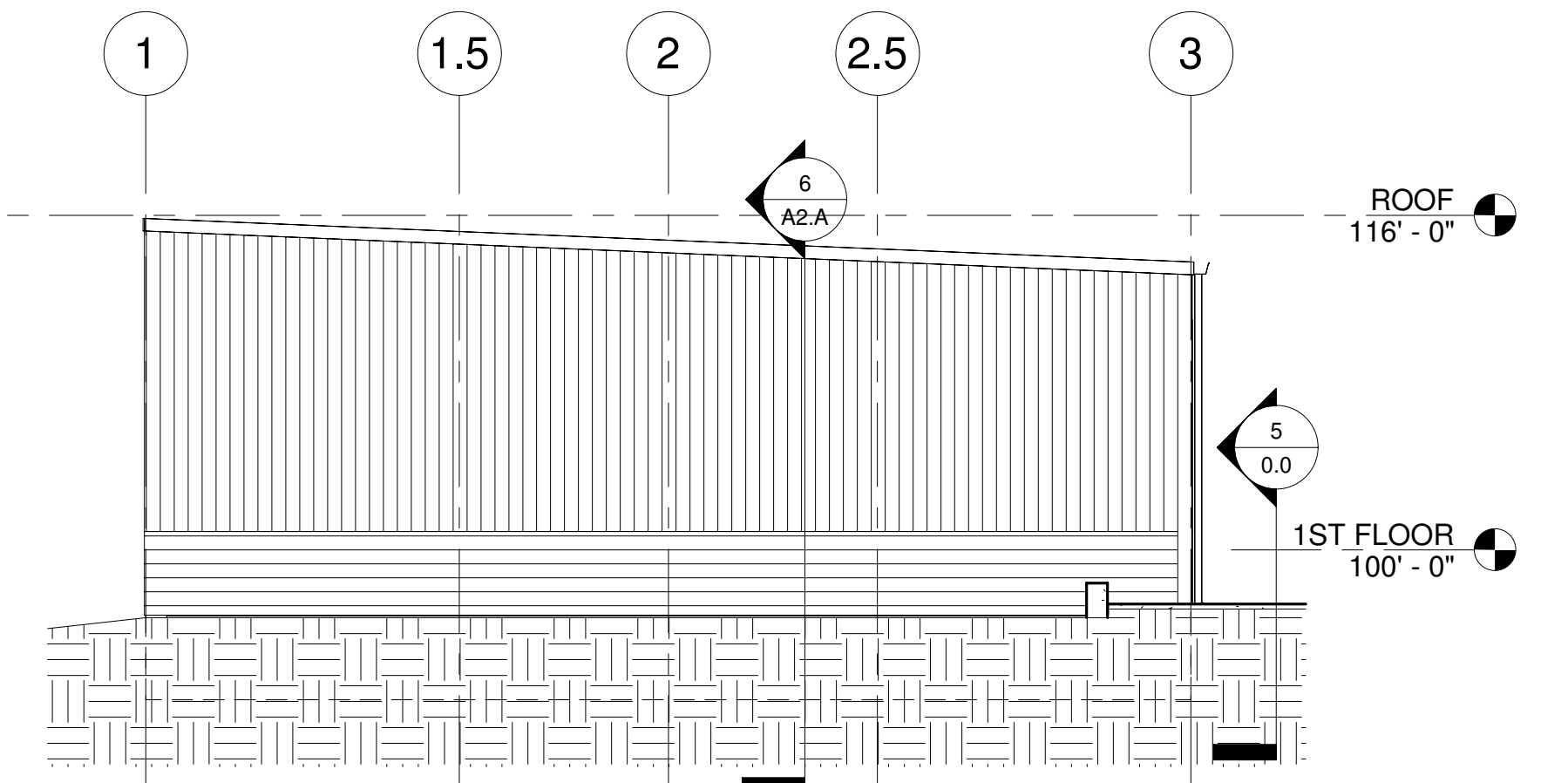

4 BLDG A - WEST ELEVATION  
1/8" = 1'-0"

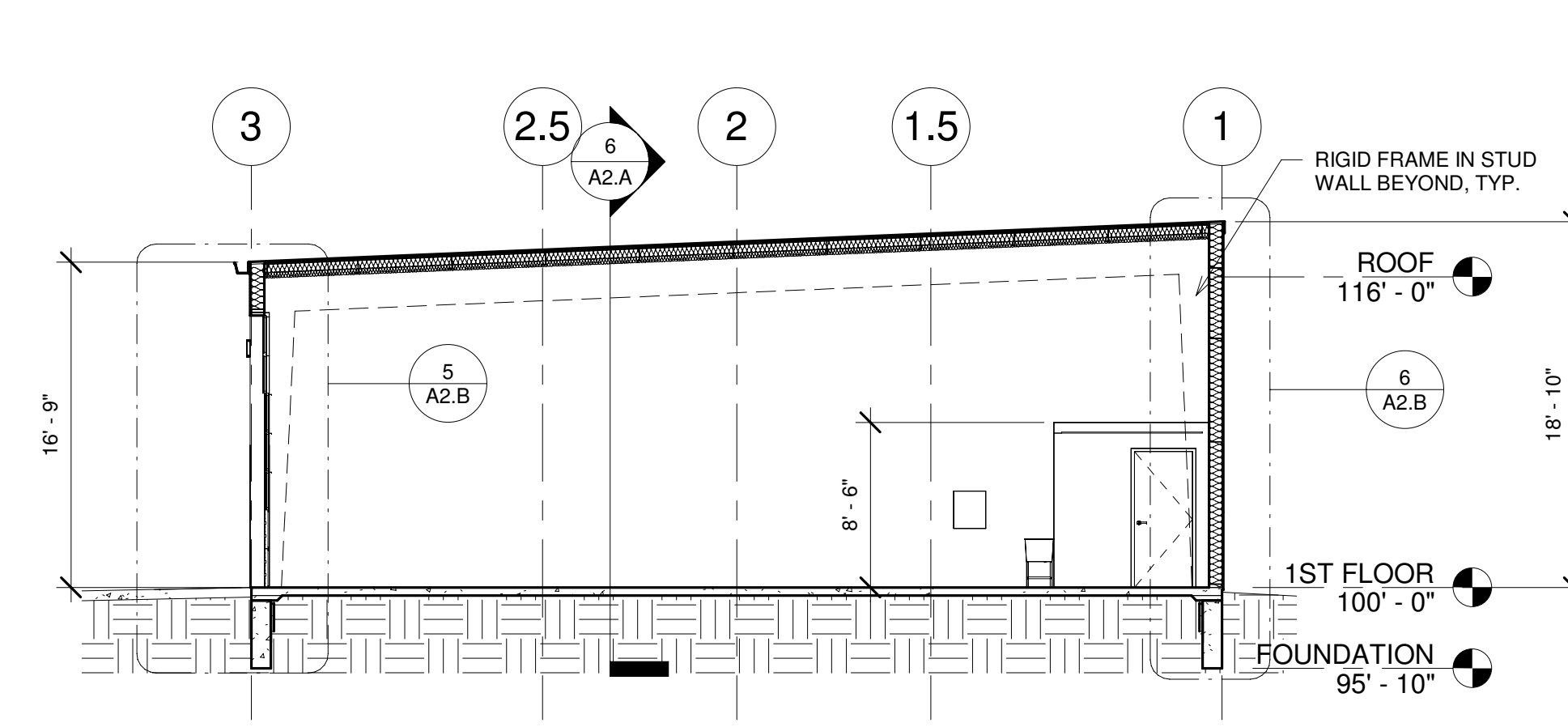

5 SECTION - BLDG A - VIEW WEST  
1/8" = 1'-0"

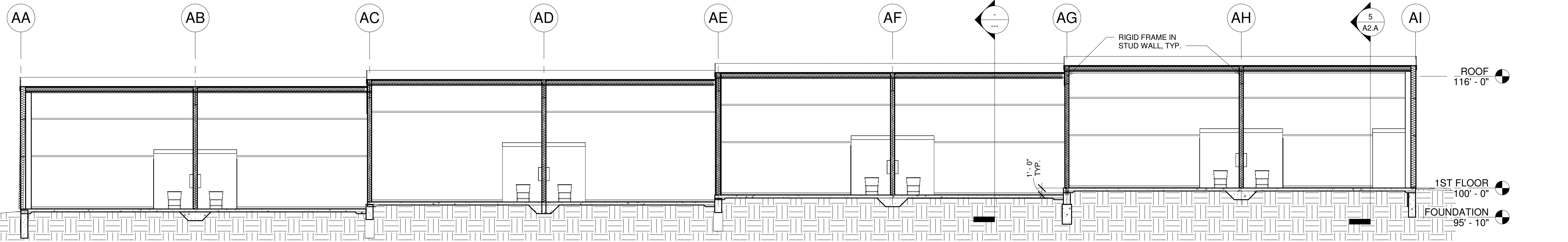

6 SECTION - BLDG A - VIEW NORTH  
1/8" = 1'-0"

**BLDG A ELEV. & SECTIONS**

REVISIONS		Date
No.	Description	

**Contractor Storage Bays**  
 McGregor Interests  
 PIN 1729720452, Bennington, NE 68007

**PJK**  
 Paul J. Kelly  
 Architecture  
 440 North 61st Street  
 Omaha, Nebraska 68132  
 (402) 320-4131  
 pjarchitecture.com

**A2.A**  
 Project No. 24-021-01  
 Date 30 October 2024



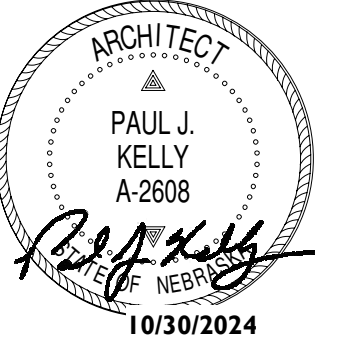

11/17/2024 12:40:00 PM

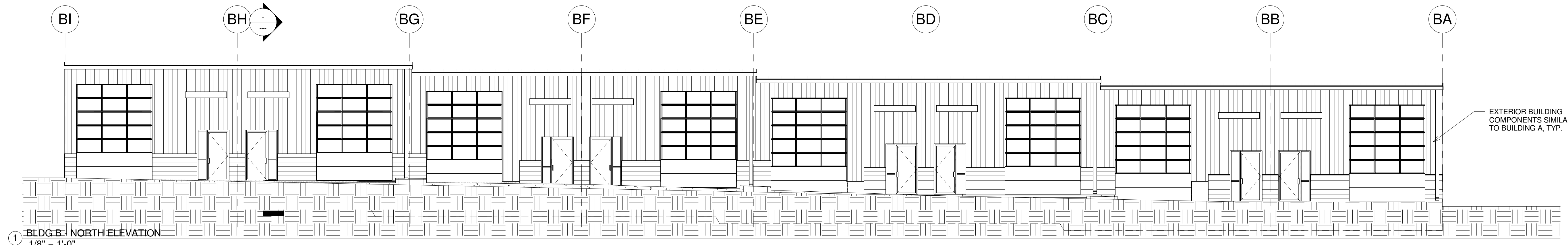

1 BLDG B - NORTH ELEVATION  
1/8" = 1'-0"

EXTERIOR BUILDING COMPONENTS SIMILAR TO BUILDING A, TYP.

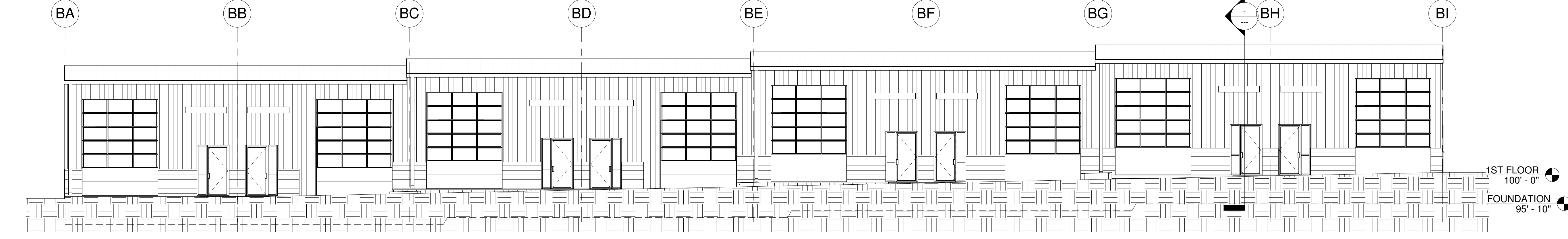

2 BLDG B - SOUTH ELEVATION  
1/8" = 1'-0"

1ST FLOOR 100' - 0"  
FOUNDATION 95' - 10"

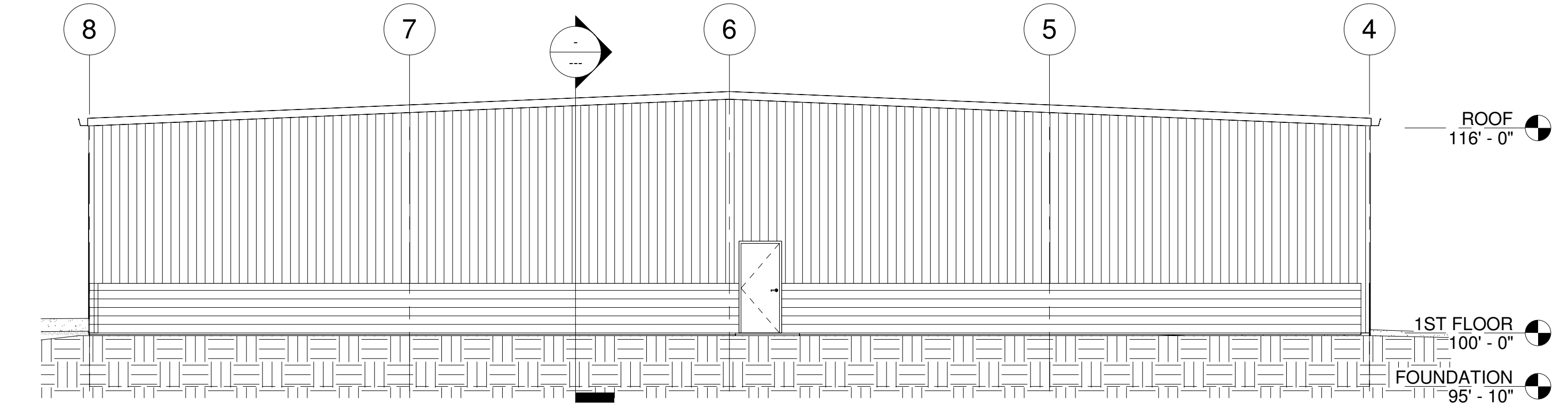

3 BLDG B - EAST ELEVATION  
1/8" = 1'-0"

ROOF 116' - 0"  
1ST FLOOR 100' - 0"  
FOUNDATION 95' - 10"

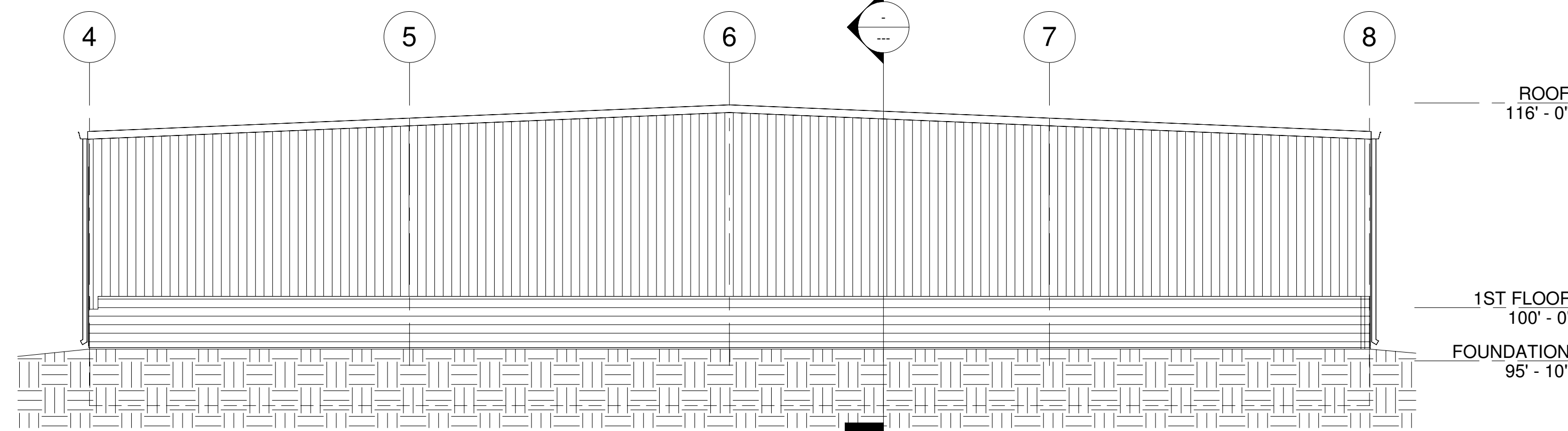

4 BLDG B - WEST ELEVATION  
1/8" = 1'-0"

ROOF 116' - 0"  
1ST FLOOR 100' - 0"  
FOUNDATION 95' - 10"

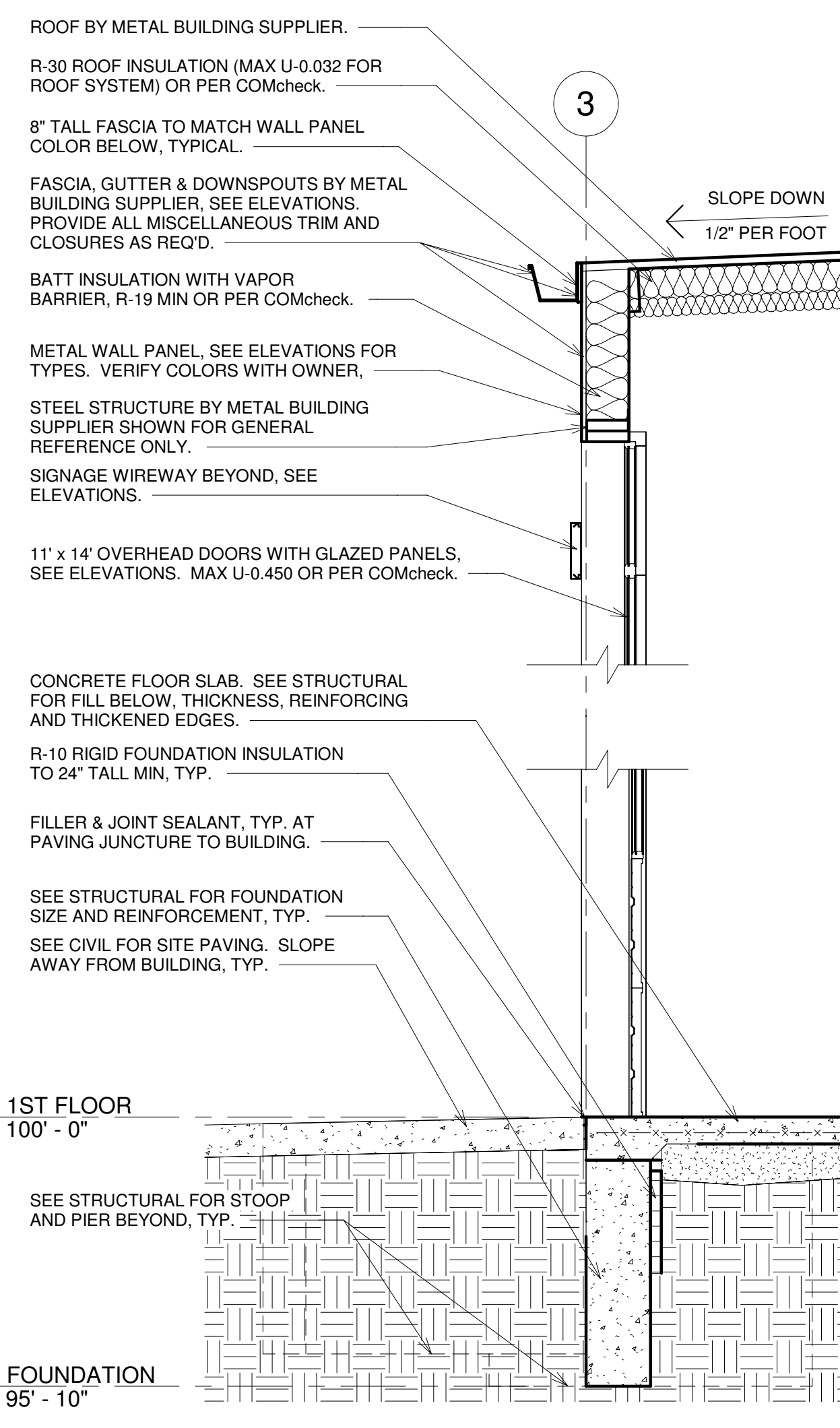

5 FRONT WALL SECTION  
1/2" = 1'-0"

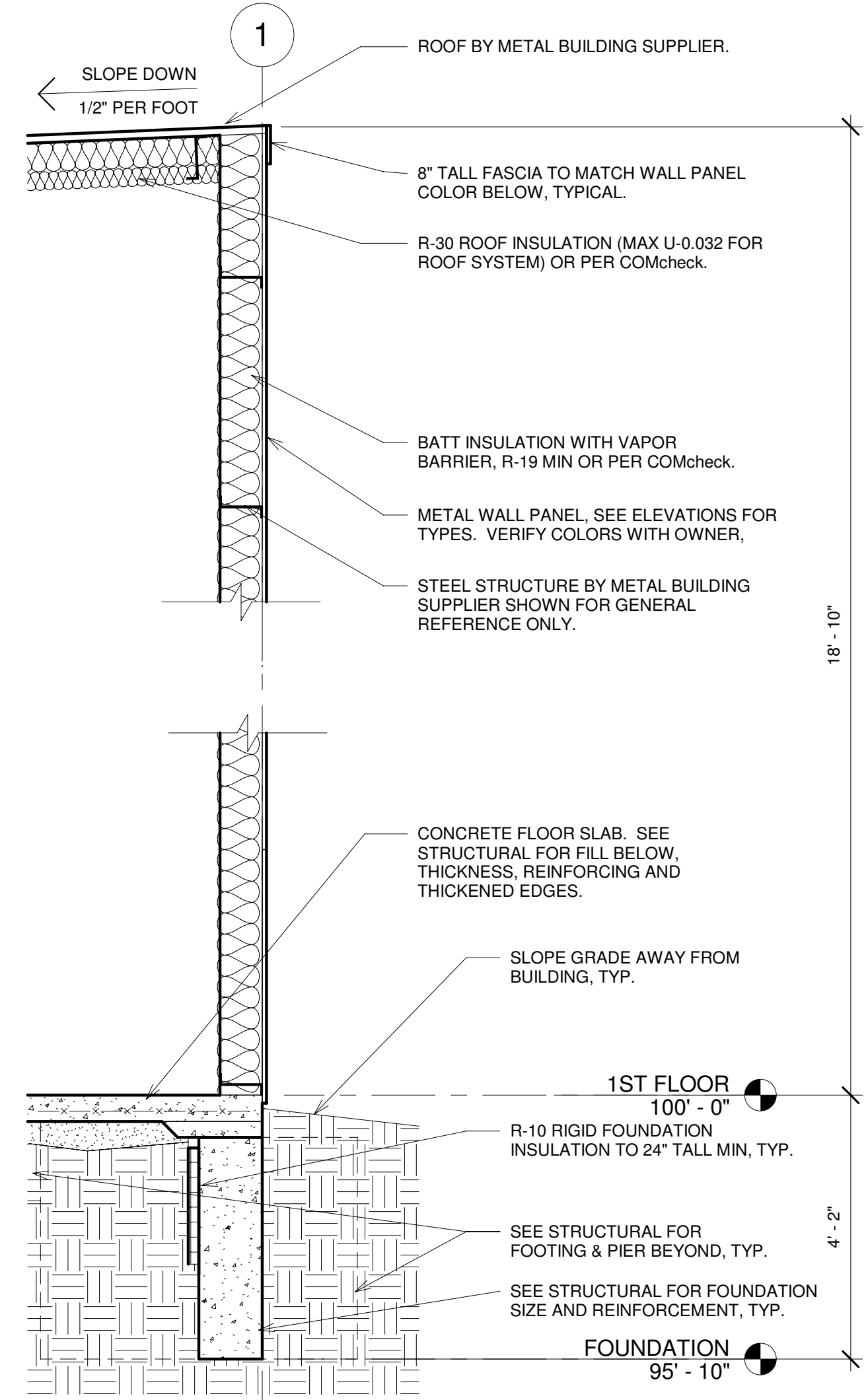

6 REAR WALL SECTION  
1/2" = 1'-0"

ROOF BY METAL BUILDING SUPPLIER.  
R-30 ROOF INSULATION (MAX U-0.032 FOR ROOF SYSTEM) OR PER COMcheck.  
8" TALL FASCIA TO MATCH WALL PANEL COLOR BELOW, TYPICAL.  
FASCIA, GUTTER & DOWNSPOUTS BY METAL BUILDING SUPPLIER. SEE ELEVATIONS. PROVIDE ALL MISCELLANEOUS TRIM AND CLOSURES AS REQ'D.  
BATT INSULATION WITH VAPOR BARRIER, R-19 MIN OR PER COMcheck.  
METAL WALL PANEL. SEE ELEVATIONS FOR TYPES. VERIFY COLORS WITH OWNER.  
STEEL STRUCTURE BY METAL BUILDING SUPPLIER SHOWN FOR GENERAL REFERENCE ONLY.  
SIGNAGE WIREWAY BEYOND, SEE ELEVATIONS.  
11' x 14' OVERHEAD DOORS WITH GLAZED PANELS. SEE ELEVATIONS. MAX U-0.450 OR PER COMcheck.  
CONCRETE FLOOR SLAB. SEE STRUCTURAL FOR FILL BELOW, THICKNESS, REINFORCING AND THICKENED EDGES.  
R-10 RIGID FOUNDATION INSULATION TO 24" TALL MIN, TYP.  
FILLER & JOINT SEALANT, TYP. AT PAVING JUNCTURE TO BUILDING.  
SEE STRUCTURAL FOR FOUNDATION SIZE AND REINFORCEMENT, TYP.  
SEE CIVIL FOR SITE PAVING. SLOPE AWAY FROM BUILDING, TYP.

SLOPE DOWN 1/2" PER FOOT  
SLOPE DOWN 1/2" PER FOOT  
SLOPE GRADE AWAY FROM BUILDING, TYP.

ROOF BY METAL BUILDING SUPPLIER.  
8" TALL FASCIA TO MATCH WALL PANEL COLOR BELOW, TYPICAL.  
R-30 ROOF INSULATION (MAX U-0.032 FOR ROOF SYSTEM) OR PER COMcheck.  
BATT INSULATION WITH VAPOR BARRIER, R-19 MIN OR PER COMcheck.  
METAL WALL PANEL. SEE ELEVATIONS FOR TYPES. VERIFY COLORS WITH OWNER.  
STEEL STRUCTURE BY METAL BUILDING SUPPLIER SHOWN FOR GENERAL REFERENCE ONLY.  
CONCRETE FLOOR SLAB. SEE STRUCTURAL FOR FILL BELOW, THICKNESS, REINFORCING AND THICKENED EDGES.  
SLOPE GRADE AWAY FROM BUILDING, TYP.

1ST FLOOR 100' - 0"  
FOUNDATION 95' - 10"

1ST FLOOR 100' - 0"  
FOUNDATION 95' - 10"

SEE STRUCTURAL FOR STOOP AND PIER BEYOND, TYP.  
SEE STRUCTURAL FOR FOOTING & PIER BEYOND, TYP.  
SEE STRUCTURAL FOR FOUNDATION SIZE AND REINFORCEMENT, TYP.

18' - 10"  
4' - 2"

BLDG B ELEV. & SECTIONS

REVISIONS		Date
No.	Description	

**Contractor Storage Bays**  
McGregor Interests  
PIN 1729720452, Bennington, NE 68007

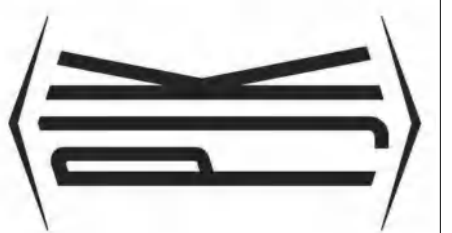

**Paul J. Kelly**  
Architect  
440 North 61st Street  
Omaha, Nebraska 68132  
(402) 320 - 4131  
pjarchitecture.com

**A2.B**  
Project No. 24-021-01  
Date 30 October 2024

Print on 22" x 34" format for proper scale







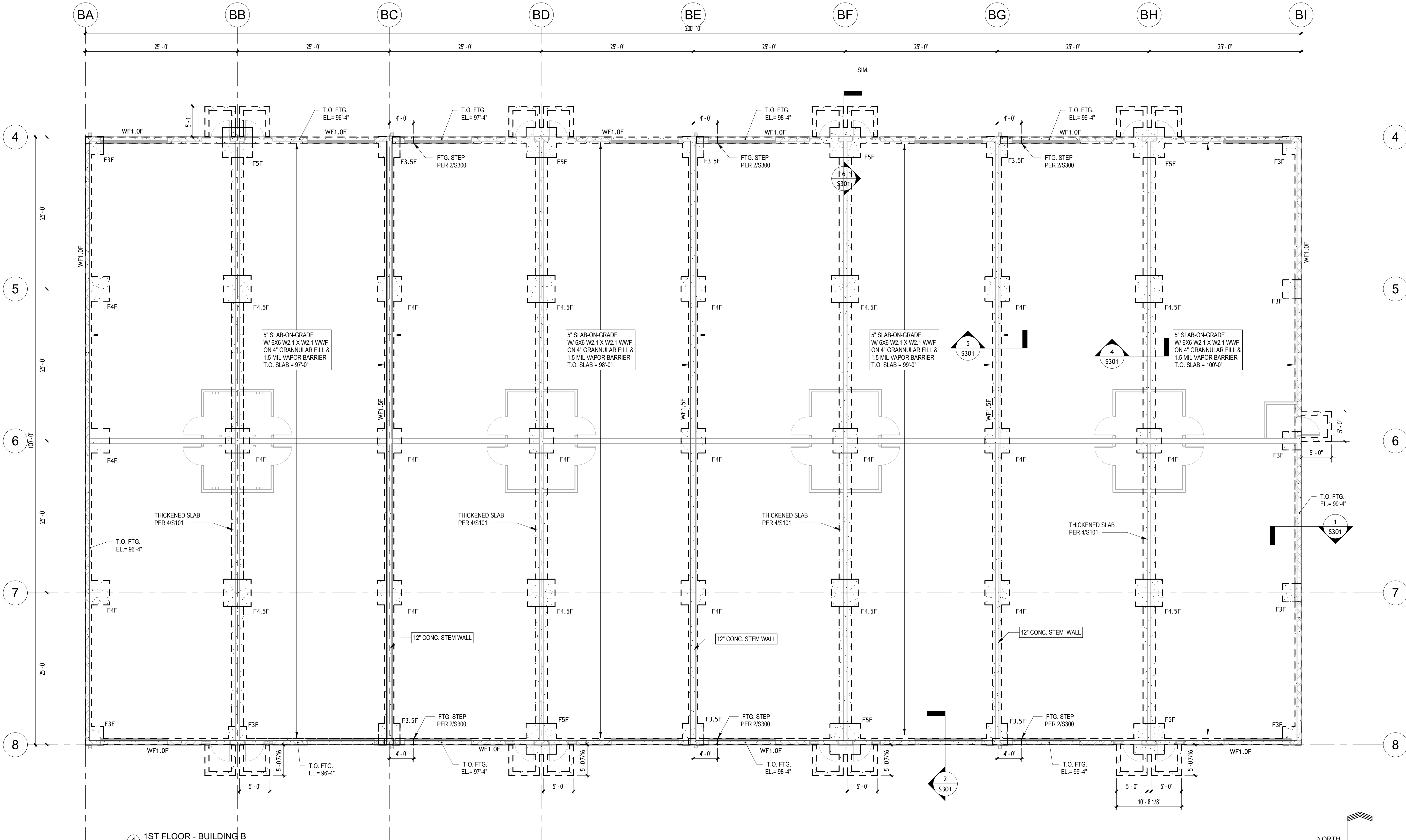

1 1ST FLOOR - BUILDING B  
1/8" = 1'-0"

**PERFORMANCE Engineering**  
 11811 Fort Street, Suite 104 - Omaha, NE 68164  
 (402) 342-3986  
 NE-CAS-2625



**FOUNDATION PLAN**  
**BUILDING B**

No.	Description	Date

**Contractor Storage Bays**  
 McGregor Interests  
 PIN 1729720452, Bennington, NE 68007

**Paul J. Kelly Architecture**  
 440 North 61st Street  
 Omaha, Nebraska 68132  
 (402) 320-4131  
 pjkararchitecture.com



**S102**

Project No. 24-021-01  
 Date 28 October 2024



**GENERAL STRUCTURAL NOTES:**

A. DESIGN DATA:

DESIGN CODE: IBC 2018

CONCRETE 28 DAY STRENGTH: FC = 4,000 PSI

MISCELLANEOUS ROLLED SECTIONS ASTM A36 AND PLATES (ANGLES, CHANNELS, PLATES, ETC.)

PLAIN BOLTS AND ANCHORS OR GR. 36 (WELDABLE, S1) ASTM F1554 GR. 36

REINFORCING STEEL ASTM A615 FY = 60,000 PSI

WELDED WIRE FABRIC ASTM A185

CONCRETE MASONRY UNITS (ASTM C90 NORMAL WEIGHT/ 1,900 PSI UNIT STRENGTH) FM = 1,500 PSI

ALLOWABLE SOIL BEARING CAPACITY 1500 PSF (ASSUMED)

DESIGN LOADS

GRAVITY LOADS: ROOFS DL = 25 PSF LL BASED ON GROUND SNOW LOAD OF 30 PSF (Ce=1.0, Ci=1.0, AND I=1.0)\*\*

\*\*INCREASE LIVE LOAD FOR SNOW DRIFTING AS REQUIRED IN CONFORMANCE WITH THE AMERICAN SOCIETY OF CIVIL ENGINEERS ANS/ASCE 7-16.

WIND LOADING CRITERIA (2018 IBC) BASE WIND SPEED (3 SECOND GUST) V' = 115 MPH BUILDING CATEGORY II IMPORTANCE FACTOR 'iw' = 1.0 EXPOSURE CATEGORY C

- B. FOUNDATION WORK:
- CONTRACTOR SHALL VERIFY FOUNDATION BEARING SOILS WILL PROVIDE A MINIMUM 1,500 PSF OF ALLOWABLE BEARING. CONSULT WITH GEOTECHNICAL ENGINEER AS NEEDED.
  - SUBSOILS SUPPORTING OR IN DIRECT CONTACT WITH FOOTINGS, SLABS ON GRADE, OR OTHER FOUNDATION ELEMENTS SHALL BE PROTECTED AGAINST FREEZING CONDITIONS THAT COULD CAUSE MOVEMENT OR OTHER DETRIMENTAL EFFECT TO THE STRUCTURE AS A WHOLE OR TO ANY OF ITS COMPONENT PARTS.
  - WHEN WORKING NEAR EXISTING AND/OR NEW CONSTRUCTION, THE CONTRACTOR SHALL EXERCISE EXTREME CAUTION SO AS NOT TO UNDERMINE, DISTURB, DAMAGE OR, IN ANY WAY, CAUSE UNDESIRABLE MOVEMENT, CRACKING, AND/OR SETTLEMENT OF THE ADJACENT CONSTRUCTION.
  - ALL SLABS ON GRADE SHALL BEAR ON UNDISTURBED VIRGIN SOIL OR PROPERLY COMPACTED BACKFILL/GRANULAR FILL. ANY UNACCEPTABLE UNDISTURBED VIRGIN SOIL OR BACKFILL/GRANULAR FILL, AS DETERMINED BY THE OWNER'S GEOTECHNICAL ENGINEER, SHALL BE REMOVED AND REPLACED AS REQUIRED BY THE GEOTECHNICAL ENGINEER.
  - CONTRACTOR SHALL COORDINATE FOOTING ELEVATIONS WITH FINAL GRADING PLAN TO PROVIDE A MINIMUM OF 42" OF GRADE ABOVE THE BOTTOM OF ALL FOOTINGS FOR FROST PROTECTION.

- C. CONCRETE:
- SUBMIT CONCRETE MIX DESIGNS FOR STRUCTURAL BUILDING CONCRETE AS A SEPARATE SUBMITTAL FROM CIVIL SITE CONCRETE.
  - FOR REINFORCEMENT DEVELOPMENT LENGTH AND SPLICE LENGTH SEE TYPICAL REINFORCEMENT TABLE ON THIS SHEET.
  - PROVIDE CORNER BARS IN WALLS AND FOOTINGS THE SAME SIZE AND NUMBER AS THE CONTINUOUS REINFORCING.
  - REINFORCING IN FOOTINGS SHALL BE ACCURATELY PLACED BEFORE PLACING CONCRETE. DO NOT FLOAT REINFORCING INTO FOOTINGS.
  - CONCRETE SHALL BE REGULAR WEIGHT (144 PCF) WITH TYPE I CEMENT, POTABLE WATER, AND AGGREGATES CONFORMING TO REQUIREMENTS OF NEBRASKA DEPARTMENT OF ROADS FOR 47-B CONCRETE, UNLESS NOTED OTHERWISE. CONCRETE SHALL CONFORM TO ACI 301-10.
  - MECHANICALLY VIBRATE CONCRETE, EXCEPT THAT SLABS ON GRADE NEED BE VIBRATED ONLY AROUND UNDERFLOOR DUCTS AND OTHER ITEMS EMBEDDED IN THE SLAB.
  - DO NOT PLACE PIPES, DUCTS, OR CHASES IN STRUCTURAL CONCRETE WITHOUT APPROVAL OF THE ARCHITECT/ENGINEER. SEE ARCHITECTURAL, MECHANICAL, AND ELECTRICAL DRAWINGS FOR LOCATIONS.
  - CONSTRUCT FORMWORK SO CONCRETE MEMBERS AND STRUCTURES ARE OF SIZE, SHAPE, ALIGNMENT, ELEVATION, AND POSITION INDICATED, WITHIN TOLERANCE LIMITS OF ACI 117.
  - CONTROL JOINTS IN SLAB-ON-GRADE SHALL BE PLACED AT COLUMN-LINE INTERSECTIONS AND AS NECESSARY TO NOT EXCEED A SPACING OF 36 TIMES THE SLAB THICKNESS. MAXIMUM ASPECT RATIO SHALL BE 1.5 TO 1.0 UNLESS NOTED OTHERWISE.
  - THICKEN SLABS ON GRADE UNDER NON-LOAD BEARING MASONRY WALLS TO 8-INCHES AND REINFORCE WITH 2-#4 CONTINUOUS.
  - ALL CONSTRUCTION JOINTS IN CONCRETE WALLS SHALL HAVE A 2' X 4' CONTINUOUS KEYWAY. ALL CONSTRUCTION JOINTS, EXCEPT THOSE DETAILED, SHALL HAVE ARCHITECT/ENGINEER APPROVAL. SEE SPECIFICATIONS FOR OTHER CONSTRUCTION JOINT REQUIREMENTS.
  - ALL REINFORCING STEEL SHALL BE DEFORMED NEW BILLETS BARS (A615, GRADE 60), BENT COLD, AND DETAILED, FABRICATED, AND HELD IN PLACE IN ACCORDANCE WITH THE "MANUAL OF STANDARD PRACTICE FOR DETAILING REINFORCED CONCRETE STRUCTURES" (ACI 315 LATEST EDITION) EXCEPT AS OTHERWISE DETAILED OR SPECIFIED.
  - THE FOLLOWING MINIMUM CONCRETE COVER SHALL BE PROVIDED FOR REINFORCEMENT, UNLESS NOTED OTHERWISE:  
CONCRETE CAST AGAINST AND PERMANENTLY EXPOSED TO EARTH: 3"  
CONCRETE EXPOSED TO EARTH OR WEATHER: 2"

- UNLESS NOTED OTHERWISE, SLABS ON GRADE SHALL BE 5" CONCRETE REINFORCED WITH 6 X 6 W2.1 X W2.1 WELDED WIRE FABRIC ON 4" GRANULAR FILL WITH 15-MIL VAPOR BARRIER. UPON APPROVAL OF ENGINEER, WELDED WIRE FABRIC MAY BE REPLACED WITH SYNTHETIC MACRO FIBER. MACRO-FIBERS SHALL BE A MINIMUM 1-1/2 INCH LENGTH, A MINIMUM ASPECT RATIO OF 70, SHALL PROVIDE A MINIMUM TENSILE STRENGTH OF 70 KSI, AND SHALL BE COMPRISED OF POLYOLEFIN FIBERS MEETING ASTM C1116M, TYPE III AND ASTM D 7508. MACRO-FIBER PRODUCT SHALL BE SUBMITTED FOR APPROVAL PRIOR TO PLACING CONCRETE FOR SLABS ON GRADE.
- ALL REINFORCING IN SLABS AND WALLS SHALL BE CONTINUOUS UNLESS DETAILED OTHERWISE AND LAP SPLICED ONLY IN REGIONS OF LOW STRESS. ALL BARS SHALL HAVE A STANDARD HOOK WHERE A HOOK IS SHOWN, UNLESS DETAILED OTHERWISE.

- D. STEEL:
- STRUCTURAL STEEL SHALL BE FABRICATED AND ERECTED IN ACCORDANCE WITH THE LATEST AISC SPECIFICATIONS AND OSHA REGULATION 29 CFR PART 1926.
  - COMPLY WITH AMERICAN WELDING SOCIETY STANDARDS. ALL WELDERS SHALL HAVE VALID CERTIFICATES AND HAVE CURRENT EXPERIENCE IN TYPE OF WELD CALLED FOR.
  - WELDING ELECTRODES SHALL BE E70 FOR ALL STEEL, UNLESS NOTED OTHERWISE.
  - ANCHOR RODS FOR COLUMN BASE PLATES SHALL BE SECURED IN PLACE WITH A TEMPLATE AND SECURELY TIED TO REINFORCING BARS BEFORE PLACING OF CONCRETE.
  - ANCHOR ROD HOLES IN BASE PLATES MAY BE OVERSIZED PER TABLE 14-2 OF THE 3RD ED. OF THE LRFD MANUAL. IF OVERSIZED HOLES ARE USED, WASHER PLATES SHALL BE PROVIDED AS SPECIFIED AND FIELD WELDED TO THE BASE PLATES.
- E. INSPECTIONS:
- IN ACCORDANCE WITH 2018 IBC SECTION 1705, AS NOTED BELOW, TESTING AND INSPECTION SHALL BE COMPLETED BY AN INDEPENDENT TESTING/INSPECTION FIRM UNDER THE SUPERVISION OF A LICENSED ENGINEER EMPLOYED BY THAT FIRM. THIS ENGINEER SHALL BE DEEMED THE DESIGNATED ENGINEER OF RECORD FOR SPECIAL INSPECTIONS PERFORMED BY HIS FIRM OR HIS CONSULTANTS. INSPECTORS SHALL BE ICBO CERTIFIED AND APPROVED BY THE BUILDING OFFICIAL.

- THE DESIGNATED ENGINEER OF RECORD FOR SPECIAL INSPECTIONS SHALL BE RESPONSIBLE FOR DEFINING THE ACTIVITIES OF THE INSPECTORS, FOR CERTIFYING THE QUALIFICATIONS OF THE INSPECTORS WITH THE BUILDING OFFICIAL AND TO ATTEND THE PRE-CONSTRUCTION MEETING TO DEFINE THEIR SCOPE OF SERVICES AND THE TESTING OR TEST PROCEDURES THAT ARE REQUIRED AS OUTLINED IN THE INTERNATIONAL BUILDING CODE.
- SPECIAL INSPECTION IS TO BE PROVIDED IN ADDITION THE INSPECTIONS CONDUCTED BY THE LOCAL DEPARTMENT OF BUILDING SAFETY AND SHALL NOT BE CONSTRUED TO RELIEVE THE OWNER OR HIS AUTHORIZED AGENT FROM REQUESTING THE PERIODIC AND CALLED INSPECTIONS REQUIRED BY SECTION 104.4 OF THE INTERNATIONAL BUILDING CODE.

- SPECIAL INSPECTIONS REQUIRED INCLUDE, BUT MAY NOT BE LIMITED TO, THE FOLLOWING:
  - CONCRETE PER SECTION 1705.3 AND TABLE 1705.3 AND ALL APPLICABLE EXCEPTIONS.
  - ANCHOR RODS INSTALLED IN CONCRETE PER TABLE 1705.3.
  - REINFORCING PER TABLE 1705.2.2 AND EXCEPTION FOR CONCRETE REQUIRING SPECIAL INSPECTION.
  - WELDING: PER SECTION 1705.3.
- OTHER:
  - VERIFY ALL DIMENSIONS AND CONDITIONS PRIOR TO STARTING WORK. NOTIFY THE ARCHITECT/ENGINEER OF ANY DISCREPANCIES OR INCONSISTENCIES.
  - VERIFY IN FIELD ALL EXISTING CONDITIONS SHOWN ON DRAWINGS.
  - ESTABLISH AND VERIFY ALL OPENINGS AND INSERTS FOR MECHANICAL, ELECTRICAL, AND PLUMBING WITH APPROPRIATE TRADES. PROVIDE ALL TEMPORARY BRACING, SHORING, GUYING, OR OTHER MEANS TO AVOID EXCESSIVE STRESSES AND TO HOLD STRUCTURAL ELEMENTS IN PLACE DURING CONSTRUCTION.
  - ANY ENGINEERING DESIGN PROVIDED BY OTHERS AND SUBMITTED FOR REVIEW SHALL BEAR THE STAMP (AND SIGNATURE) OF AN ENGINEER REGISTERED IN NEBRASKA.

**TYPICAL REINFORCING NOTES:**

- REINFORCING BAR DEVELOPMENT AND LAP SPLICE LENGTH SHALL BE AS SHOWN IN THIS TABLES UNLESS OTHERWISE NOTED ON THE DRAWINGS.
- THE LENGTHS SHOWN IN THE TABLES ARE BASED ON THE FOLLOWING CONCRETE COVERAGE AND REINFORCING C-C SPACING:  
BEAMS OR COLUMNS:  
COVER (EQUAL OR MORE) 1.0bd (BAR DIAMETER)  
CENTER TO CENTER (C-C) SPACING (EQUAL OR MORE) 2.0bd.  
ALL OTHERS:  
COVER (EQUAL OR MORE) 1.0bd  
CENTER TO CENTER SPACING (EQUAL OR MORE) 3.0bd.
- TOP BARS ARE DEFINED AS HORIZONTAL REINFORCEMENT SUCH THAT MORE THAN 12 INCHES OF FRESH CONCRETE IS CAST IN THE MEMBER BELOW THE DEVELOPMENT LENGTH OR SPLICE.
- DEVELOPMENT AND SPLICE LENGTH SHOWN SHALL NOT APPLY IF ANY OF THE FOLLOWING CONDITIONS OCCUR:  
A) fc < 4000 PSI  
B) fy > 60,000 PSI  
C) THE COVER OR C-C BAR SPACING IS NOT AS LISTED ABOVE  
D) THE REINFORCING STEEL IS EPOXY COATED  
E) LIGHT WEIGHT CONCRETE IS USED.
- CENTER ON CENTER SPACING (S) IS DEFINED AS BELOW:

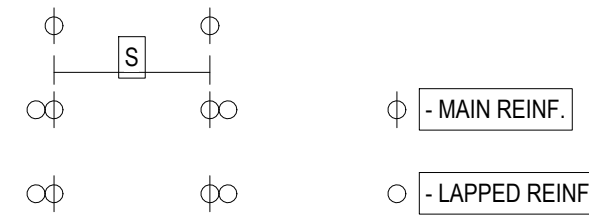

BAR SIZE	REINFORCING DEVELOPMENT AND SPLICES fc = 4000 PSI			
	DEVELOPMENT LENGTH		SPLICE LENGTH	
	OTHER	TOP	OTHER	TOP
#3	1'-3"	1'-7"	1'-7"	2'-0"
#4	1'-7"	2'-1"	2'-1"	2'-8"
#5	2'-0"	2'-7"	2'-7"	3'-4"
#6	2'-5"	3'-1"	3'-1"	4'-0"
#7	3'-6"	4'-6"	4'-6"	5'-10"
#8	4'-0"	5'-2"	5'-2"	6'-8"
#9	4'-6"	5'-10"	5'-10"	7'-7"
#10	5'-1"	6'-7"	6'-7"	8'-6"
#11	5'-7"	7'-3"	7'-3"	9'-5"

**DEVELOPMENT LENGTH NOTES:**

- WHERE DRAWINGS ARE DETAILED SIMILAR TO DETAIL 2, EXTEND THE EMBEDMENT LENGTH SUCH THAT THE HOOKED BAR CONTACTS THE LAYER OF MAIN REINFORCING SHOWN.
- EMBEDMENT LENGTHS IN CHART ARE TYPICAL EXCEPT AS NOTED IN DETAIL 2, OR AS INDICATED ON DRAWINGS.

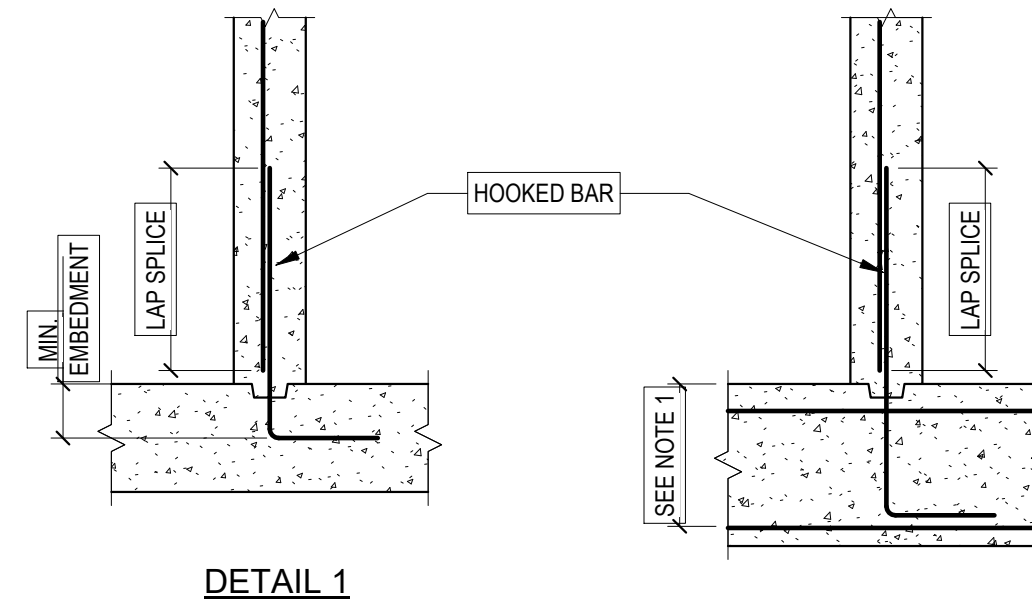

BAR SIZE	DEVELOPMENT LENGTHS HOOKED BARS (fc = 4000 PSI)	
	LENGTH OR MIN. EMBEDMENT	
#3	7"	
#4	10"	
#5	1'-0"	
#6	1'-3"	
#7	1'-5"	
#8	1'-7"	
#9	1'-10"	
#10	2'-0"	
#11	2'-3"	

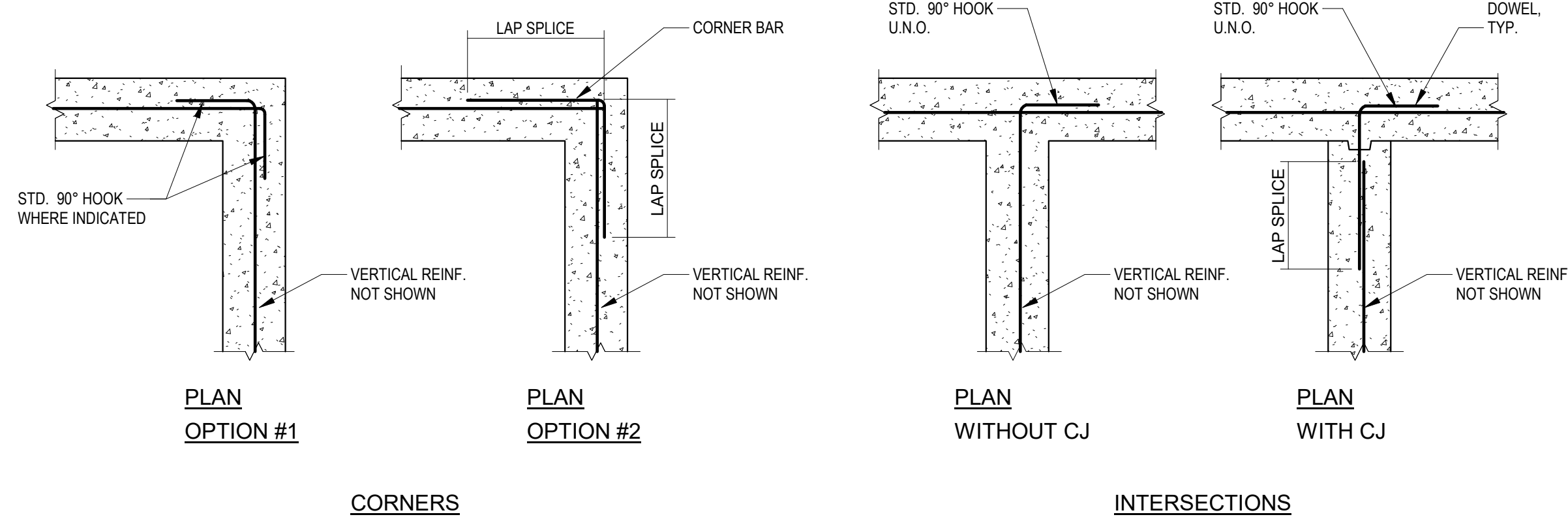
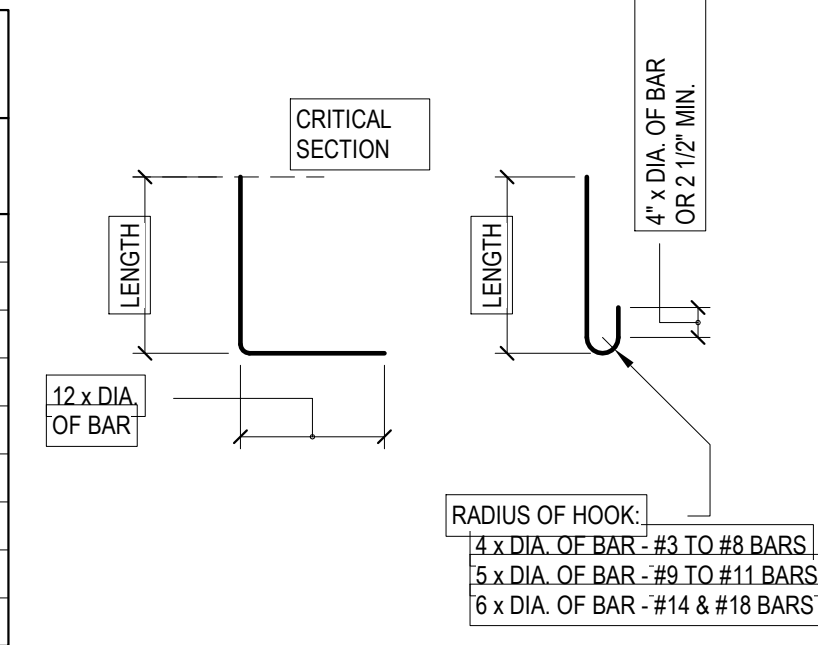

NOTE: UNLESS OTHERWISE INDICATED, THE CONTRACTOR HAS THE OPTION OF REINFORCING CORNERS IN ACCORDANCE WITH OPTION #1 OR OPTION #2.

NOTE: UNLESS OTHERWISE INDICATED, THE CONTRACTOR HAS THE OPTION OF CONSTRUCTING INTERSECTIONS WITH OR WITHOUT CONSTRUCTION JOINTS. REINFORCE PER APPLICABLE DETAIL.

**HORIZONTAL WALL REINFORCEMENT DETAILS**

NOTE: SAW JOINT AS SOON AS SURFACE IS FIRM ENOUGH NOT TO BE TORN OR DAMAGED BY THE BLADE (USUALLY 4 TO 12 HOURS AFTER CONCRETE HARDENS). SEE SPECIFICATIONS.

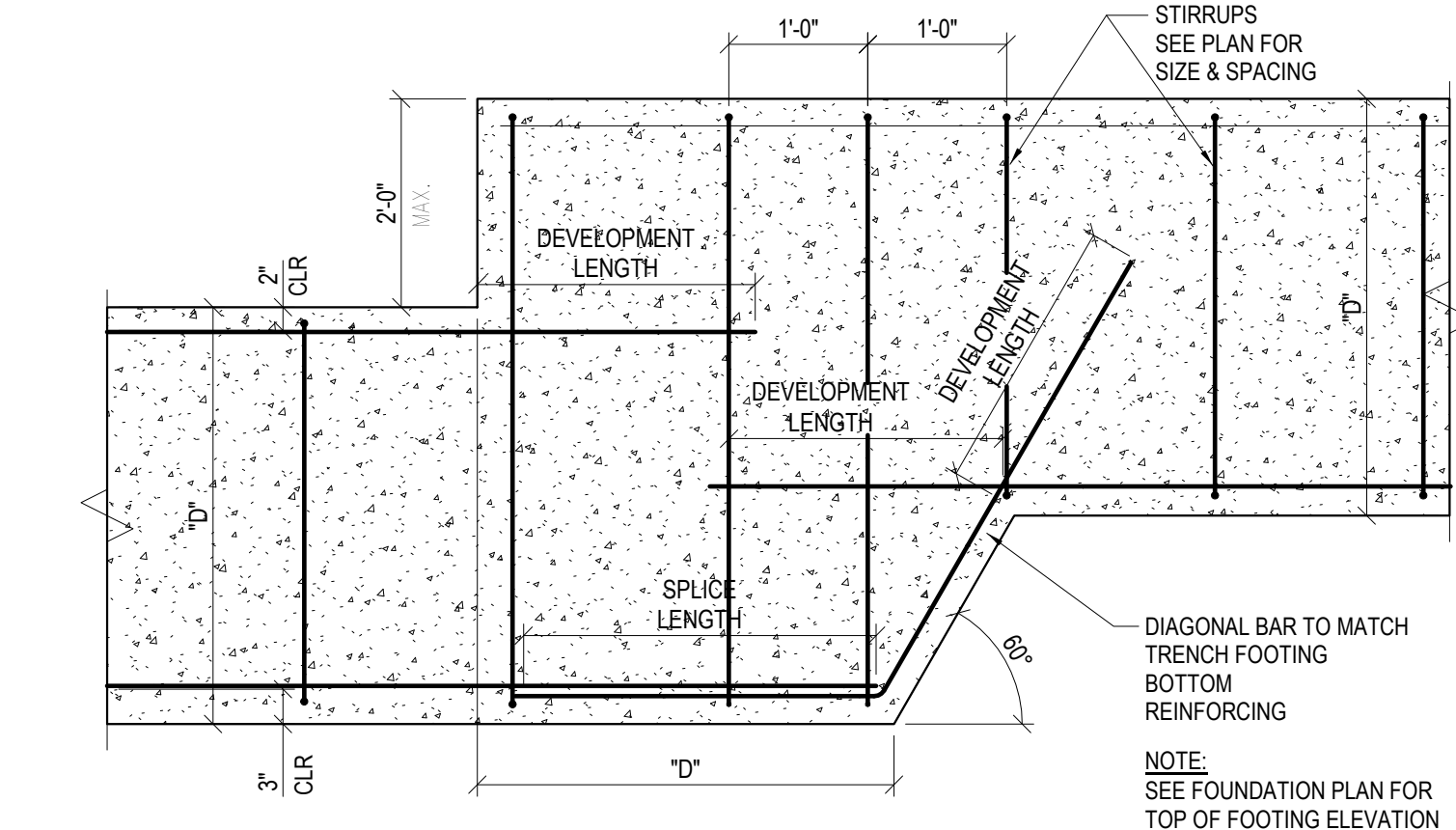
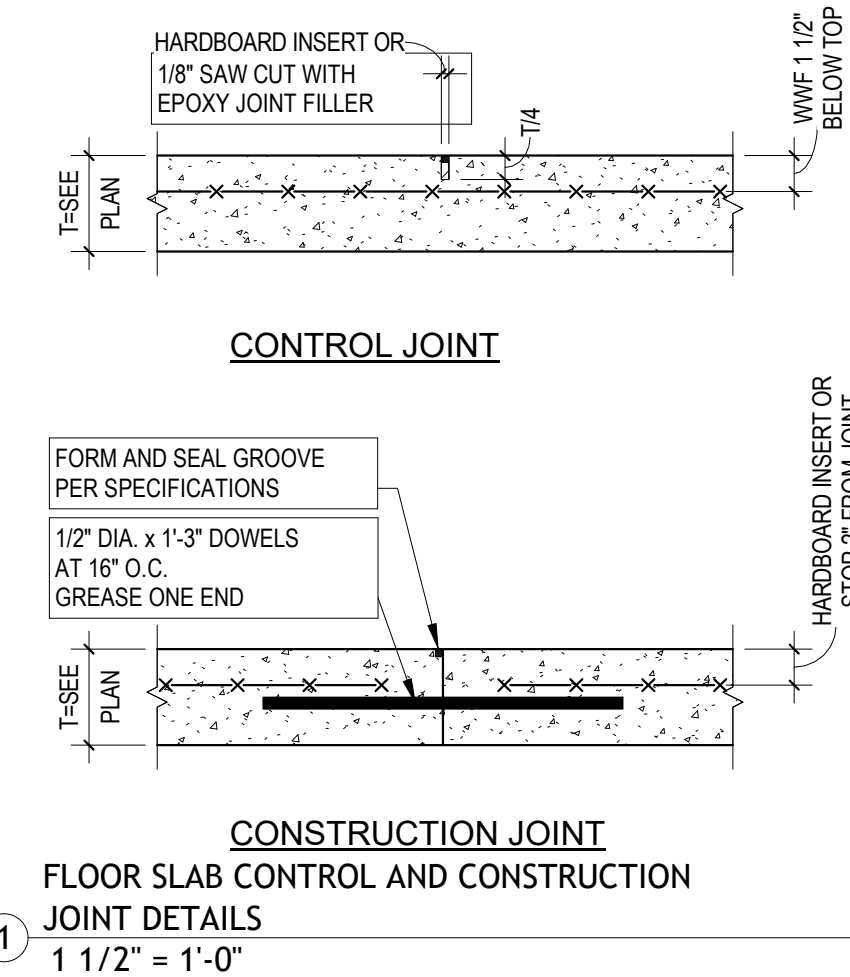

**PERFORMANCE Engineering**  
11811 Fort Street, Suite 104 - Omaha, NE 68164 389 Perry St., Suite 201A - Omaha, NE 68104  
(402) 340-3461 (402) 721-3322  
NE-CAS-65  
PE # 241012

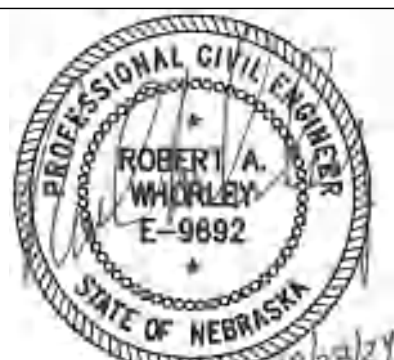

GENERAL STRUCTURAL NOTES AND DETAILS		Date
No.	Description	

**Contractor Storage Bays**  
McGregor Interests  
PIN 1729720452, Bennington, NE 68007

**Paul J. Kelly Architect**  
440 North 61st Street  
Omaha, Nebraska 68132  
(402) 320-4131  
pkjarchitecture.com

**S300**  
Project No. 24-021-01  
Date 28 October 2024



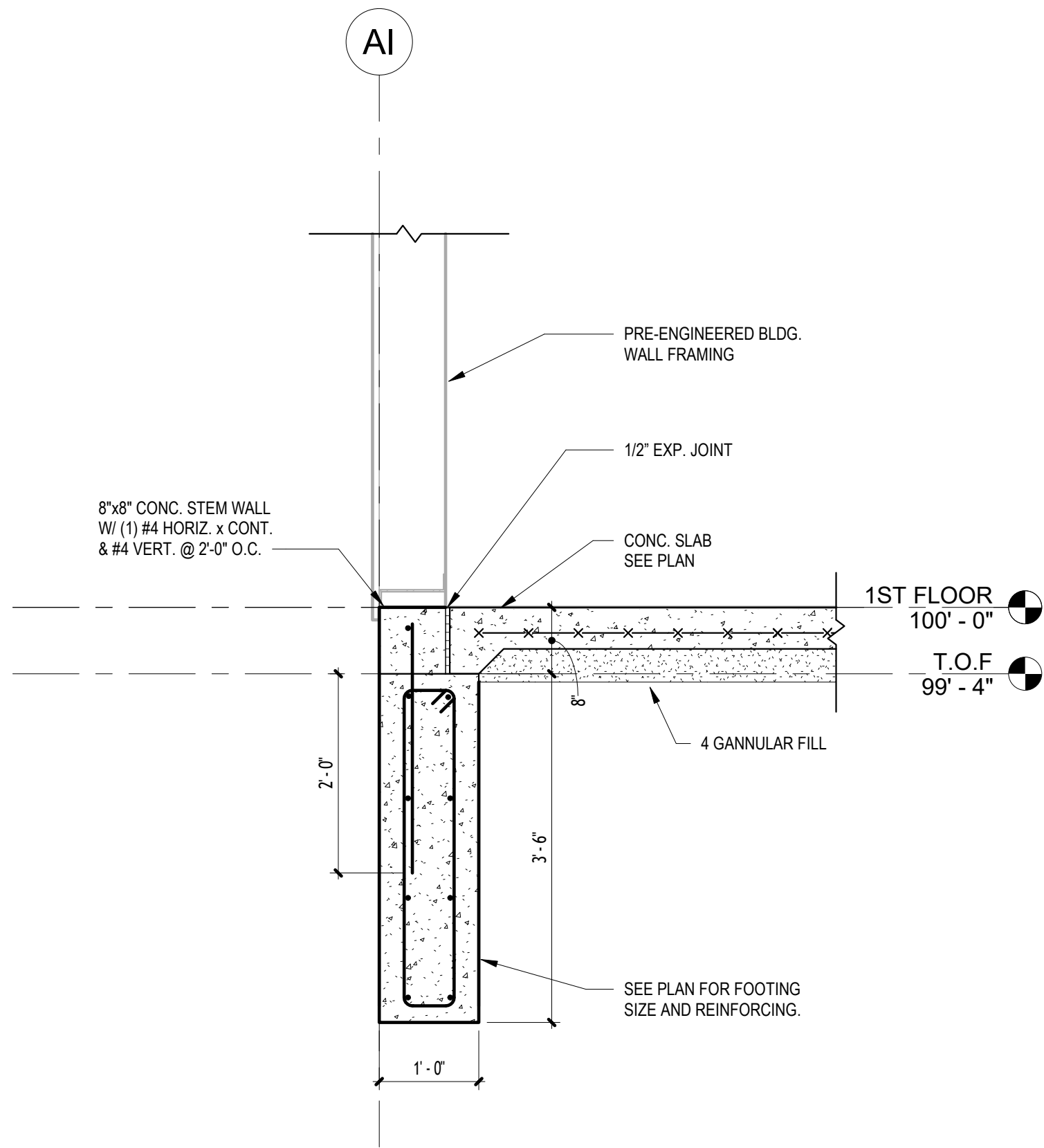

1 FOOTING SECTION  
3/4" = 1'-0"

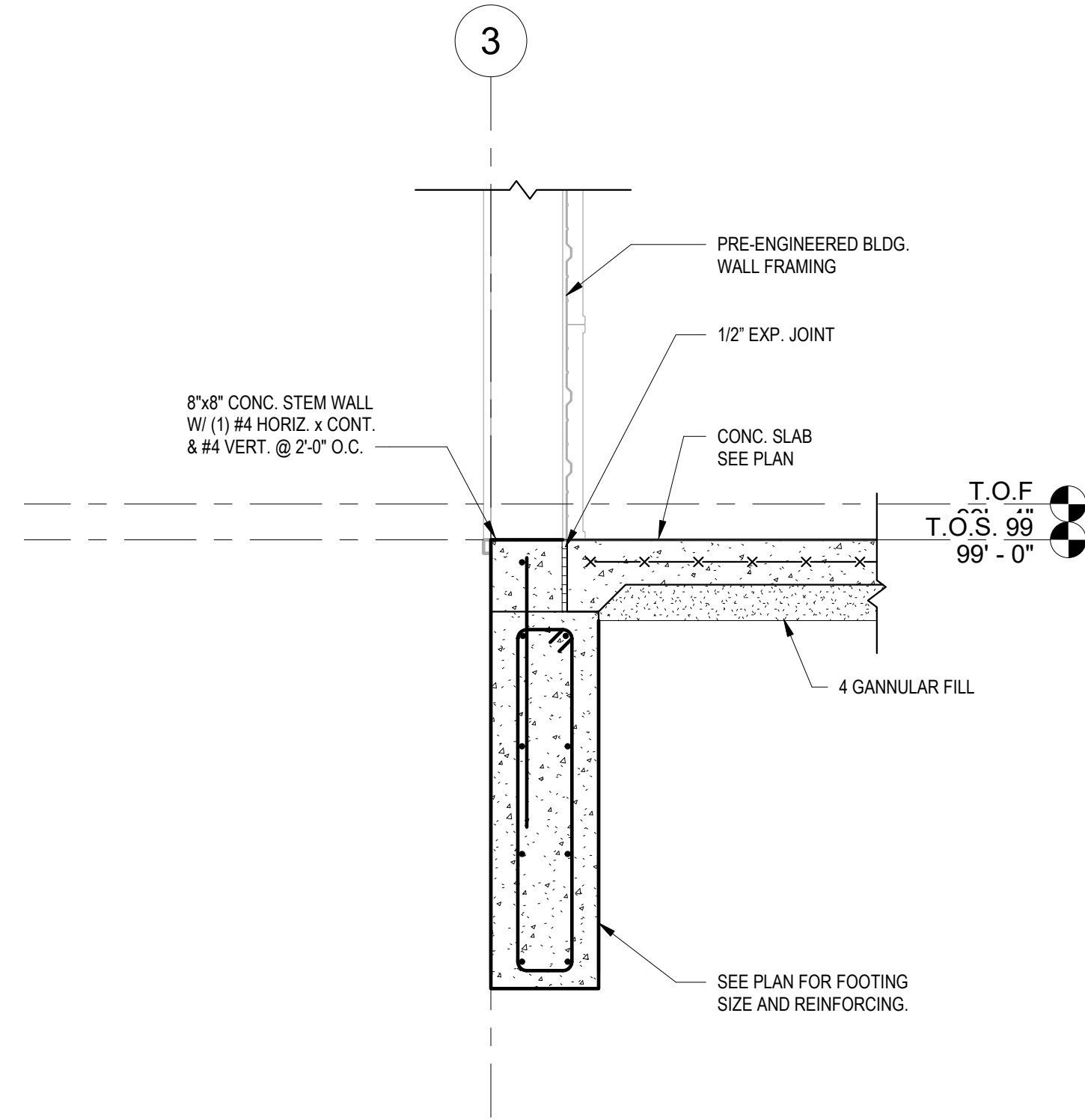

2 FOOTING SECTION  
3/4" = 1'-0"

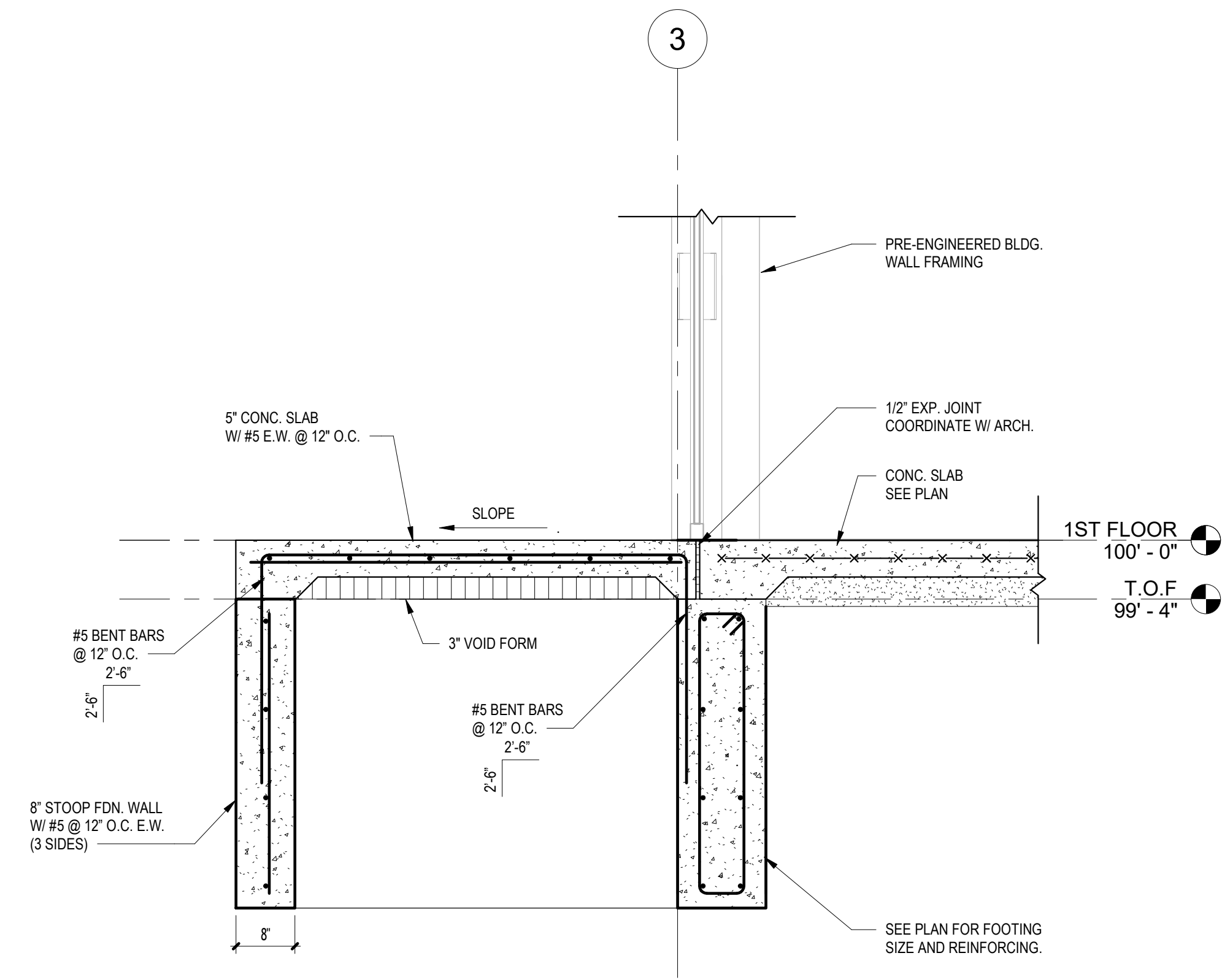

3 STOOP SECTION  
3/4" = 1'-0"

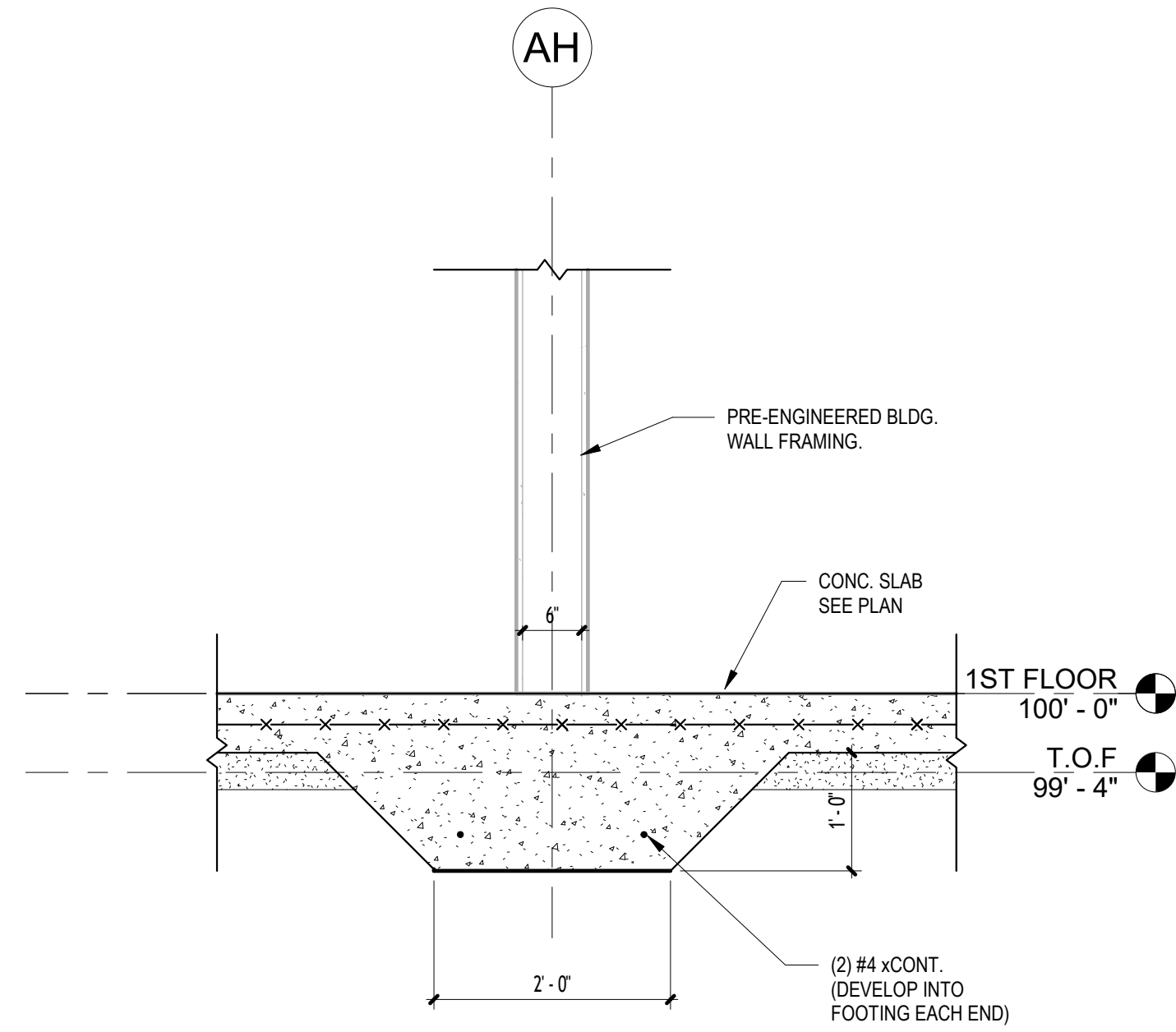

4 THICKENED SLAB  
3/4" = 1'-0"

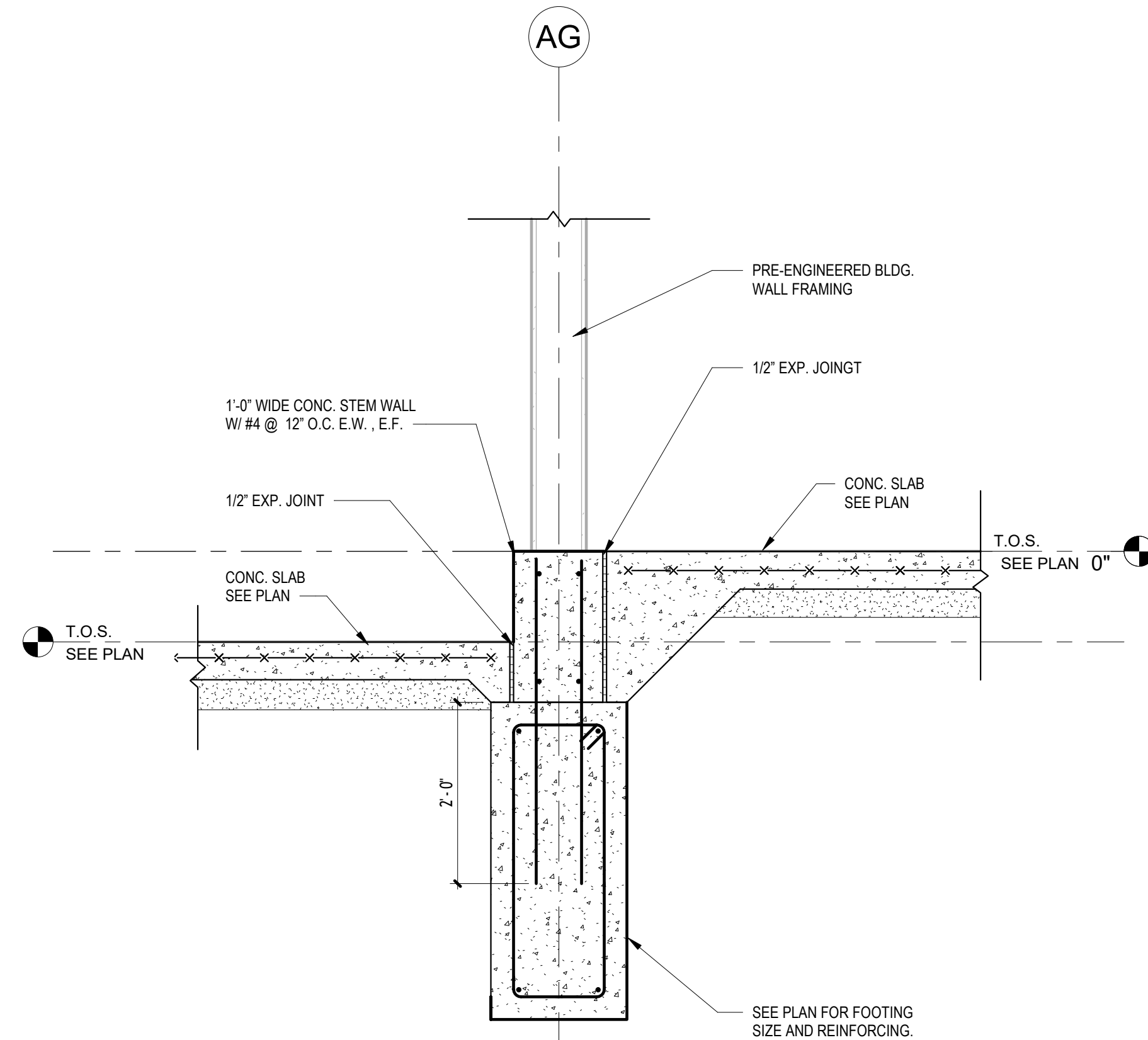

5 FOOTING SECTION  
3/4" = 1'-0"

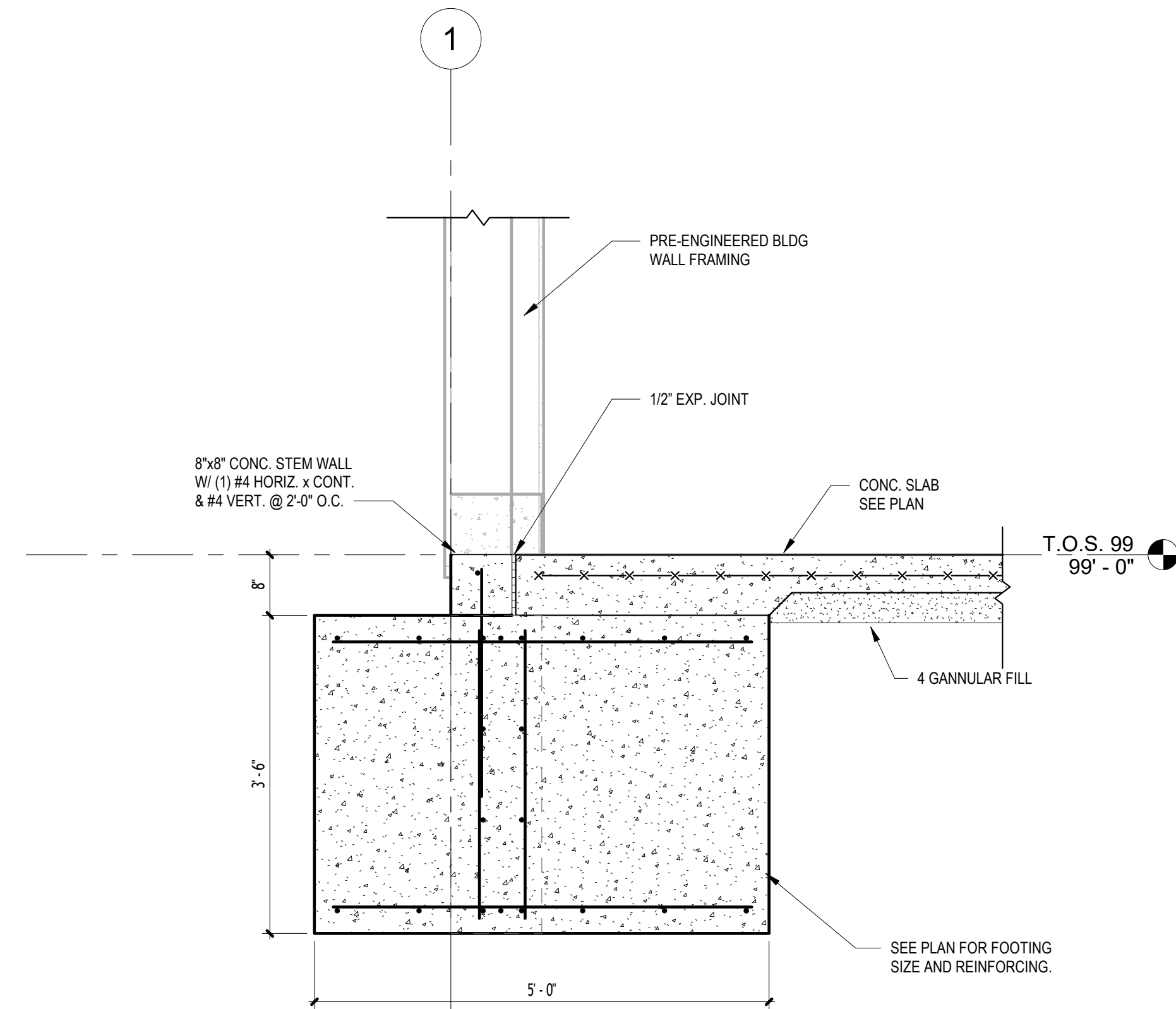

6 FOOTING SECTION  
3/4" = 1'-0"



11811 Fort Street, Suite 104 - Omaha, NE 68164 389 Perry St., Suite 201A - Castle Rock, CO 80104  
(402) 340-5986 (402) 340-5981  
NE-CAS-65

PE # 241012

SECTIONS AND DETAILS

REVISIONS		Date
No.	Description	

# Contractor Storage Bays

McGregor Interests  
PIN 1729720452, Bennington, NE 68007



Paul J. Kelly  
Architecture  
440 North 61st Street  
Omaha, Nebraska 68132  
(402) 320-4131  
pkjarchitecture.com

# S301

Project No. 24-021-01  
Date 28 October 2024





# PLUMBING AND MECHANICAL SYMBOLS LEGEND

(AS APPLICABLE)

SYMBOL	DESCRIPTION	SYMBOL	DESCRIPTION	SYMBOL	DESCRIPTION
	REFRIGERANT DISCHARGE		PROPYLENE GLYCOL RETURN		INLINE PUMP
	REFRIGERANT LIQUID		PROPYLENE GLYCOL SUPPLY		AIR VENT - MANUAL
	REFRIGERANT SUCTION		FUEL OIL RETURN		AIR VENT - AUTOMATIC
	COIL CONDENSATE DRAIN		FUEL OIL SUPPLY		FLOW SWITCH
	LOW PRESSURE STEAM (PRESSURE)		FUEL OIL VENT		PRESSURE SWITCH
	MEDIUM PRESSURE STEAM (PRESSURE)		CONDENSER WATER RETURN		AIR SEPARATOR
	HIGH PRESSURE STEAM (PRESSURE)		CONDENSER WATER SUPPLY		THERMOMETER
	LOW PRESSURE CONDENSATE		HEAT PUMP WATER RETURN		THERMOMETER WELL
	MEDIUM PRESSURE CONDENSATE		HEAT PUMP WATER SUPPLY		BALL JOINT
	HIGH PRESSURE CONDENSATE		PITCH OF PIPE, RISE (R) OR DROP (D)		PUMP SUCTION DIFFUSER
	PUMPED CONDENSATE		PIPE ANCHOR - MAIN		FLOAT THERMOSTATIC TRAP
	MAKE-UP WATER		PIPE ANCHOR - INTERMEDIATE		FLOWMETER - ORIFICE
	HOT/CHILLED WATER RETURN		HANGER - ROD		FLOWMETER - VENTURI
	HOT/CHILLED WATER SUPPLY		HANGER - SPRING		DUPLEX STRAINER
	HEATING WATER RETURN		ALIGNMENT GUIDE		ELECTRICAL PANEL - SHOWN FOR COORDINATION PURPOSES ONLY
	HEATING WATER SUPPLY		FLEX CONNECTOR		ELECTRICAL TRANSFORMER - SHOWN FOR COORDINATION PURPOSES ONLY
	CHILLED WATER RETURN		EXPANSION - LOOP		
	CHILLED WATER SUPPLY		EXPANSION - JOINT		
	ETHYLENE GLYCOL RETURN				
	ETHYLENE GLYCOL SUPPLY				

## DUCTWORK

	SUPPLY (SA), OUTSIDE (OA), VENTILATION (VA) AIR DUCT (UP/DOWN/SECTION)		ELEVATION CHANGE (RISE OR DROP)		FIRE DAMPER (IN HORIZONTAL DUCT)
	RETURN (RA) AIR DUCT (UP/DOWN/SECTION)		HIGH EFF. TAKE OFF FITTING WITH VOLUME DAMPER		SMOKE DAMPER (IN HORIZONTAL DUCT)
	EXHAUST (EA) AIR DUCT (UP/DOWN/SECTION)		BACKDRAFT DAMPER		FIRE DAMPER (IN VERTICAL DUCT)
	RECTANGLE DUCT (WIDTH/HEIGHT/SYSTEM)		TURNING VANES		SMOKE DAMPER (IN VERTICAL DUCT)
	ROUND DUCT (DIAMETER/SYSTEM)		VOLUME CONTROL DAMPER		FIRE/SMOKE DAMPER (IN HORIZONTAL DUCT)
	FLAT OVAL DUCT (WIDTH/HEIGHT/SYSTEM)		VOLUME CONTROL DAMPER		FIRE/SMOKE DAMPER (IN VERTICAL DUCT)
	FLEXIBLE DUCTWORK		OPPOSED BLADE DAMPER		DUCT ACCESS PANEL
			PARALLEL BLADE DAMPER		RELIEF PANEL
					DUCT END CAP

## H.V.A.C.

	SUPPLY DIFFUSER		VAV TERMINAL UNIT		THERMOSTAT
	SUPPLY REGISTER		FAN POWERED VAV TERMINAL UNIT		THERMOSTAT WITH GUARD
	SUPPLY SLOT DIFFUSER		SIDE WALL DIFFUSER		TEMPERATURE SENSOR - XX-X DENOTES SERVED
	RETURN REGISTER		ROUND DIFFUSER		CARBON MONOXIDE SENSOR
	RETURN GRILLE		EXTERIOR LOUVER		CARBON DIOXIDE SENSOR
	EXHAUST REGISTER		SUPPLY IDENTIFICATION TAG X DENOTES TYPE		NITROGEN DIOXIDE SENSOR
	EXHAUST GRILLE		RETURN/ EXHAUST LOUVER IDENTIFICATION TAG X DENOTES TYPE		HUMIDITY SENSOR
	DUAL DUCT TERMINAL UNIT		MOTORIZED ACTUATOR		PRESSURE SENSOR
			PNEUMATIC ACTUATOR		TEMPERATURE SENSOR WITH GUARD
					HUMIDISTAT
					EMERGENCY SHUTDOWN SWITCH

## FITTINGS

	ELBOW		ELBOW - DOUBLE BRANCH		REDUCER - CONCENTRIC
	LONG RADIUS ELBOW		ELBOW - SIDE OUTLET UP		REDUCER - ECCENTRIC
	SHORT RADIUS ELBOW		ELBOW - SIDE OUTLET DOWN		CAPPED CONNECTION
	45° ELBOW		ELBOW - OUTLET DOWN		THREADED CONNECTION
	TEE		TEE - OUTLET UP		FLANGED CONNECTION
	CROSS		TEE - OUTLET DOWN		STRAINER
	LATERAL		TEE - OUTLET UP		STRAINER WITH BALL VALVE DRAIN
	TEE - SINGLE SWEEP		TEE - SIDE OUTLET DOWN		STRAINER WITH COUPLER
			TEE - SIDE OUTLET UP		BUSHING
			SIAMESE CONNECTION		FLOW DIRECTION

## VALVES

	GATE VALVE		STOP/CHECK GATE VALVE (ARROW IND. FLOW)		MULTIPURPOSE VALVE
	ANGLE GATE VALVE		SPRING GATE CHECK VALVE (ARROW IND. FLOW)		PRESSURE REDUCING VALVE
	BALL VALVE		SWING GATE CHECK VALVE (ARROW IND. FLOW)		PRESSURE REDUCING PILOT VALVE
	LOCKABLE BALL VALVE		ANGLE STOP/CHECK VALVE		REDUCED PRESS. BACKFLOW ASSY.
	BUTTERFLY VALVE		2-WAY ELECTROMOTOR VALVE		DOUBLE CHK VALVE BACKFLOW ASSY.
	GLOBE VALVE		2-WAY AIRMOTOR VALVE		DOUBLE DETECTOR CHECK VALVE
	ANGLE GLOBE VALVE		3-WAY ELECTROMOTOR VALVE		OUTSIDE STEM & YOKE VALVE
	PLUG VALVE		3-WAY AIRMOTOR VALVE		QUICK CLOSING FUSIBLE LINK VALVE
	DIAPHRAGM VALVE		3-WAY MANUAL VALVE		QUICK OPENING VALVE
	DIAPHRAGM ACTUATED VALVE		SAFETY PRESSURE RELIEF VALVE		PRESSURE GAUGE & BALL VALVE
	VALVE IN VERTICAL LINE		GATE VALVE WITH GLOBE VALVE BY-PASS		GLOBE VALVE WITH GLOBE VALVE BY-PASS
	HOSE GATE VALVE		SPRINKLER - CONCEALED		SPRINKLER - RECESSED
	HOSE GLOBE VALVE		SPRINKLER - SIDEWALL		SPRINKLER - UPRIGHT
	HOSE ANGLE VALVE		SPRINKLER - ZONE CONTROL		
	SOLENOID VALVE				
	POST INDICATOR VALVE				

## MEDICAL PIPING

	MEDICAL AIR		MEDICAL NITROGEN		MEDICAL VACUUM
	MEDICAL NITROUS OXIDE		MEDICAL OXYGEN		WASTE ANESTHETIC GAS DISPOSAL

## PLUMBING

	PIPE REMOVAL		NON-POTABLE COLD WATER		TRAP PRIMER
	DOMESTIC COLD WATER		NON-POTABLE HOT WATER		HOSE BIBB
	DOMESTIC HOT WATER		NON-POTABLE SOFT WATER		WALL HYDRANT
	DOMESTIC HOT WATER RECIRC.		PUMPED DISCHARGE		ROOF HYDRANT
	DOMESTIC SOFT WATER		NATURAL GAS (PSIG)		CLEAN OUT
	SANITARY		PROPANE GAS (PSIG)		FLOOR CLEAN OUT
	STORM		VENT		FLOOR DRAIN
	STORM OVERFLOW		ACID WASTE		VENT THRU ROOF (V = DENOTE IDENTIFICATION)
	GREASE WASTE		ACID VENT		ROOF DRAIN
	COMPRESSED AIR		OIL/SAND		OVERFLOW ROOF DRAIN
	PROCESSED AIR		IRRIGATION		DOWNSPOUT NOZZLE

## MISCELLANEOUS

	EQUIPMENT IDENTIFICATION TAG (ELECTRICAL CONNECTION REQUIRED)		NEW CONNECTION POINT		WATER CLOSET
	DETAIL REFERENCE SHEET REFERENCE		POINT OF DISCONNECT		URINAL
	SECTION CUT REFERENCE SHEET REFERENCE		OUTSIDE AIR		LAVATORY
	ELECTRICAL PANEL - SHOWN FOR COORDINATION PURPOSES ONLY		VENTILATION AIR		SINK
	ELECTRICAL PANEL - SHOWN FOR COORDINATION PURPOSES ONLY		EXHAUST AIR		DRINKING FOUNTAIN
	ELECTRICAL PANEL - SHOWN FOR COORDINATION PURPOSES ONLY		RELIEF OR RETURN AIR		ELECTRIC WATER COOLER
	ELECTRICAL PANEL - SHOWN FOR COORDINATION PURPOSES ONLY		SUPPLY AIR		SERVICE SINK
	ELECTRICAL PANEL - SHOWN FOR COORDINATION PURPOSES ONLY		MIXED AIR		SHOWER
	ELECTRICAL PANEL - SHOWN FOR COORDINATION PURPOSES ONLY		RELIEF OR RETURN FAN		DOMESTIC WATER HEATER
	ELECTRICAL PANEL - SHOWN FOR COORDINATION PURPOSES ONLY		EXHAUST FAN		MOP SINK BASIN
	ELECTRICAL PANEL - SHOWN FOR COORDINATION PURPOSES ONLY		DUST COLLECTION EXHAUST (TYP)		DASHED DARK LINEWORK = DEMOLITION
	ELECTRICAL PANEL - SHOWN FOR COORDINATION PURPOSES ONLY		TYPICAL		LIGHT LINEWORK = EXISTING
					DARK LINEWORK = NEW

## GENERAL MECHANICAL NOTES

APPLY TO ALL MECHANICAL SHEETS

- LIGHT LINE WEIGHT INDICATES EXISTING ITEMS AND ASSOCIATED MATERIALS TO REMAIN. BOLD LINE WEIGHT INDICATES NEW WORK TO BE INSTALLED UNDER THIS CONTRACT. ROUTING INDICATED ON DRAWINGS IS APPROXIMATE AND DOES NOT INCLUDE ALL OFFSETS, FITTINGS, VALVES, ETC. CONTRACTOR TO FIELD VERIFY DUCT SIZE AND SERVICE PRIOR TO FINAL CONNECTION. COORDINATE LOCATION OF HVAC WORK WITH LIGHTING, STRUCTURAL MEMBERS, PIPING SYSTEMS, ETC. PROVIDE OFFSETS AND CLEARANCES OR RELOCATE HVAC WORK AS REQUIRED TO AVOID CONFLICTS WITH WORK OF ALL OTHER TRADES.
- HVAC WORK SHALL NOT BE LOCATED OVER ELECTRICAL, DATA, OR COMMUNICATION EQUIPMENT ROOMS. HVAC WORK SHALL NOT BE LOCATED ABOVE ELECTRICAL / DATA / COMMUNICATION EQUIPMENT OR PANELS.
- SUPPORT ALL DUCTWORK, PIPING, EQUIPMENT, ETC. FROM BUILDING STRUCTURE. HOLD PIPING TIGHT TO BOTTOM OF STRUCTURAL MEMBERS OR RUN THROUGH JOIST WEBS IF POSSIBLE. DO NOT USE WIRE OR PERFORATED METAL TO SUPPORT PIPING. DO NOT SUPPORT PIPING FROM OTHER PIPING, DUCTWORK AND/OR ELECTRICAL CONDUITS. DO NOT SUPPORT FROM BOTTOM OF CHORD OF BAR JOIST OR FROM METAL ROOF DECK. ALL DUCT SIZES SHOWN ARE CLEAR AIRWAY DIMENSIONS. INCREASE SHEET METAL SIZE TO ACCOMMODATE DUCT LINER AS REQUIRED.
- ELBOWS SHALL BE CONSTRUCTED WITH CENTERLINE RADIUS OF NOT LESS THAN 1-1/2 TIMES THE WIDTH OF DUCT. WHERE SPACE CONDITIONS DO NOT PERMIT THIS RADIUS OR WHERE INDICATED ON DRAWINGS SQUARE ELBOWS WITH TURNING VANES SHALL BE USED. SIZE TRANSITIONS WITH A MINIMUM SLOPE OF 1:4.
- PROVIDE DRAW BANDS AND SEAL END OF DUCT INSULATION ON ALL FLEXIBLE CONNECTIONS. MAXIMUM LENGTH OF FLEXIBLE DUCTS SHALL BE THREE FEET.
- CONTRACTOR SHALL BE RESPONSIBLE FOR PROPERLY SEALING PENETRATIONS THROUGH A FIRE RATED, SMOKE RATED OR COMBINATION FIRE & SMOKE RATED SEPARATIONS. SEE SPECIFICATIONS FOR FIRE & SMOKE RATED SEALANTS. SEE ARCHITECTURAL PLANS FOR RATED SEPARATIONS.
- COORDINATE ALL GRILLE, REGISTER AND DIFFUSER LOCATIONS WITH REFLECTED CEILING PLAN, LIGHT FIXTURES, SPRINKLER HEADS, COMMUNICATION/SOUND DEVICES AND FIRE ALARM DEVICES.
- INSTALL ESCUTCHEON PLATES ON ALL WALL PENETRATIONS SERVING ROUND DUCT WALL PENETRATIONS. FABRICATE ESCUTCHEON PLATES TO TRIM THE OPENING IN THE WALL.
- INSTALL WALL ANGLE FOR ALL RECTANGULAR DUCT PENETRATIONS THROUGH WALLS. FOR EXPOSED DUCTWORK THOROUGHLY CLEAN, REMOVE ALL SHIPPING LABELS AND OTHER IDENTIFICATION TAGS. DUCTWORK DESIGNATED TO BE PAINTED SHALL HAVE PHOSPHATIZED FINISH. PROVIDE MILL-PHOSPHATIZED FINISH FOR EXPOSED NOT DESIGNATED TO BE PAINTED. COORDINATE WITH ARCHITECTURAL DRAWINGS DUCTWORK DESIGNATED FOR PAINTING AND EXPOSED DUCTWORK REQUIREMENTS.
- PROVIDE DUCT MOUNTED ACCESS DOOR AT FIRE DAMPER, SMOKE DAMPER OR COMBINATION FIRE/SMOKE DAMPERS TO ALLOW FOR MAINTENANCE AND VISUAL INSPECTION PER NFPA REQUIREMENTS.
- VOLUME DAMPERS ABOVE INACCESSIBLE CEILINGS SHALL HAVE EXTENSION RODS AND ESCUTCHEON PLATES.
- LOCATE AND INSTALL EQUIPMENT TO PROVIDE ALL CODE AND MANUFACTURER'S RECOMMENDED CLEARANCES. KEEP HVAC PIPING, DUCTWORK, ETC. OUT OF CLEARANCE AREAS.
- ALL OPENINGS IN WALLS AND FLOORS FOR PIPING SHALL BE CORE DRILLED OR SAW CUT, UNLESS OTHERWISE NOTED.
- ALL HVAC PIPING WORK SHALL BE LOCATED ABOVE CEILINGS, IN A PIPE CHASE, OR OTHER CONCEALED LOCATIONS, UNLESS OTHERWISE NOTED. LOCATE AND ARRANGE VALVES, DRAIN FITTINGS, ETC. TO BE ACCESSIBLE THROUGH LAY-IN CEILINGS, ACCESS PANELS OR ACCESS DOORS. PROVIDE ACCESS PANEL OR ACCESS DOOR FOR ALL VALVES, DRAIN FITTINGS, ETC. AT NON-ACCESSIBLE LOCATIONS.
- INSTALL SECTIONAL VALVES ON EACH BRANCH AND/OR RISER SERVING TWO OR MORE HYDRONIC TERMINALS OR EQUIPMENT CONNECTIONS. INSTALL VALVES ADJACENT TO MAIN.
- INSTALL SHUTOFF VALVES ON INLET AND OUTLET OF EACH MECHANICAL EQUIPMENT ITEM AND/OR EACH HYDRONIC TERMINAL.
- SLOPE HVAC PIPING TO DRAIN VALVES. PROVIDE MANUAL AIR VENTS AT HIGH POINTS AND AT TOP OF RISERS.
- SEAL ALL HVAC PENETRATIONS. SEAL PENETRATIONS THROUGH RATED WALLS, FLOORS OR CEILINGS WITH MATERIALS APPROPRIATE FOR RATING.
- PIPING IN EXTERIOR WALLS SHALL BE LOCATED ON THE INTERIOR SIDE OF BUILDING INSULATION AND VAPOR BARRIER.
- COORDINATE INSTALLATION OF BUILDING INSULATION TO RUN CONTINUOUS BETWEEN PIPING AND EXTERIOR WALL SURFACE.
- PVC PIPING SHALL NOT BE INSTALLED IN ANY RETURN AIR PLENUM UNLESS THE PIPING IS INSTALLED IN A PRE-APPROVED RATED ASSEMBLY.
- COORDINATE DUCTWORK WITH STRUCTURAL CROSS BRACING. PROVIDE TOP AND BOTTOM BRIDGING BETWEEN JOISTS WHERE DUCTWORK IS TO BE INSTALLED BETWEEN THE JOISTS. COORDINATE WITH ALL TRADES.

## GENERAL PLUMBING NOTES

APPLY TO ALL PLUMBING SHEETS

- LIGHT LINE WEIGHT INDICATES EXISTING ITEMS AND ASSOCIATED MATERIALS TO REMAIN. BOLD LINE WEIGHT INDICATES NEW WORK TO BE INSTALLED UNDER THIS CONTRACT.
- ROUTING INDICATED ON DRAWINGS IS APPROXIMATE AND DOES NOT INCLUDE ALL OFFSETS, FITTINGS, VALVES, ETC. CONTRACTOR TO FIELD VERIFY PIPE SIZE AND SERVICE PRIOR TO FINAL CONNECTION. COORDINATE LOCATION OF PLUMBING PIPING WORK WITH LIGHTING, STRUCTURAL MEMBERS, HVAC, PIPING SYSTEMS, ETC. PROVIDE OFFSETS AND CLEARANCES OR RELOCATE PLUMBING WORK AS REQUIRED TO AVOID CONFLICTS WITH WORK OF ALL OTHER TRADES.
- PLUMBING WORK SHALL NOT BE LOCATED OVER ELECTRICAL, DATA OR COMMUNICATION EQUIPMENT ROOMS. PLUMBING WORK SHALL NOT BE LOCATED ABOVE ELECTRICAL / DATA / COMMUNICATION EQUIPMENT OR PANELS.
- SUPPORT ALL PLUMBING PIPING, EQUIPMENT, ETC. FROM BUILDING STRUCTURE. HOLD PIPING TIGHT TO BOTTOM OF STRUCTURAL MEMBERS OR RUN THROUGH JOIST WEBS IF POSSIBLE. DO NOT USE WIRE OR PERFORATED METAL TO SUPPORT PIPING. DO NOT SUPPORT PIPING FROM OTHER PIPING, DUCTWORK AND/OR ELECTRICAL CONDUITS. DO NOT SUPPORT FROM BOTTOM OF CHORD OF BAR JOIST OR FROM METAL ROOF DECK. ROUTE ABOVE GRADE DRAINAGE PIPING AS HIGH AS POSSIBLE AND COORDINATE WITH OTHER TRADES.
- CONTRACTOR SHALL BE RESPONSIBLE FOR PROPERLY SEALING PENETRATIONS THROUGH A FIRE RATED, SMOKE RATED OR COMBINATION FIRE & SMOKE RATED SEPARATIONS. SEE SPECIFICATIONS FOR FIRE & SMOKE RATED SEALANTS. SEE ARCHITECTURAL PLANS FOR RATED SEPARATIONS.
- INSTALL ESCUTCHEON PLATES ON ALL WALL AND FLOOR PENETRATIONS SERVING EXPOSED PLUMBING PIPING WALL PENETRATIONS.
- ALL OPENINGS IN WALLS AND FLOORS FOR PIPING SHALL BE CORE DRILLED OR SAW CUT, UNLESS OTHERWISE NOTED.
- LOCATE AND INSTALL EQUIPMENT TO PROVIDE ALL CODE AND MANUFACTURER'S RECOMMENDED CLEARANCES. KEEP HVAC PIPING, DUCTWORK, ETC. OUT OF CLEARANCE AREAS.
- ALL PLUMBING PIPING WORK SHALL BE LOCATED ABOVE CEILINGS, IN A PIPE CHASE, OR OTHER CONCEALED LOCATIONS, UNLESS OTHERWISE NOTED. LOCATE AND ARRANGE VALVES, DRAIN FITTINGS, ETC. TO BE ACCESSIBLE THROUGH LAY-IN CEILINGS, ACCESS PANELS OR ACCESS DOORS. PROVIDE ACCESS PANEL OR ACCESS DOOR FOR ALL VALVES, DRAIN FITTINGS, ETC. AT NON-ACCESSIBLE LOCATIONS.
- INSTALL SECTIONAL VALVES ON EACH BRANCH AND/OR RISER SERVING TWO OR MORE PLUMBING FIXTURES OR EQUIPMENT CONNECTIONS. INSTALL VALVES ADJACENT TO MAIN.
- INSTALL SHUTOFF VALVES ON INLET AND OUTLET OF PLUMBING EQUIPMENT.
- INSTALL STOPS AT EACH PLUMBING FIXTURE EXCEPT AT FLUSHMETER LOCATIONS.
- SEAL ALL PLUMBING PIPING PENETRATIONS. SEAL PENETRATIONS THROUGH RATED WALLS, FLOORS OR CEILINGS WITH MATERIALS APPROPRIATE FOR RATING.
- PIPING IN EXTERIOR WALLS SHALL BE LOCATED ON THE INTERIOR SIDE OF BUILDING INSULATION AND VAPOR BARRIER.
- COORDINATE INSTALLATION OF BUILDING INSULATION TO RUN CONTINUOUS BETWEEN PIPING AND EXTERIOR WALL SURFACE.
- COORDINATE EXACT LOCATION OF FLOOR DRAINS AND FLOOR SINKS. TOP OF GRATE SHALL BE 1/8" BELOW FINISHED FLOOR ELEVATION.
- COMPLY WITH LOCAL UTILITY COMPANY RULES AND REGULATIONS FOR ALL GAS METER INSTALLATIONS. COORDINATE EXACT LOCATION OF GAS CONNECTIONS WITH EQUIPMENT SUPPLIER.
- COPPER PIPING LOCATED ABOVE GRADE SHALL BE TYPE "L". COPPER PIPING LOCATED BELOW GRADE SHALL BE TYPE "K" AND RUN CONTINUOUS WITHOUT JOINTS BELOW GRADE. TYPE "M" COPPER SHALL NOT BE USED ON PRESSURIZED PIPING SYSTEMS.
- DRAINAGE PIPING 3 INCHES AND SMALLER SHALL SLOPE NO LESS THAN 1/4" INCH PER FOOT. DRAINAGE PIPING 4 INCHES AND LARGER SHALL SLOPE NO LESS THAN 1/8" INCH PER FOOT.
- INSTALL WALL CLEAN OUTS (WCO) WHEN LOCATED BEHIND A WATER CLOSET AT 30" A.F.F. OR AT 42" A.F.F. ABOVE CABINETRY ON ALL SANITARY & STORM STACKS.
- COORDINATE EXACT STORM PIPE CONNECTIONS WITH STORM DRAIN LOCATIONS SHOWN ON ARCHITECTURAL ROOF PLAN.
- INSTALL VENT-THRU-ROOF (VTR) A MINIMUM OF 10'-0" AWAY FROM ANY OUTSIDE AIR INTAKE.
- REMOVE, REPAIR AND REPLACE WALLS, FLOORS, ROOFS AND CEILINGS TO MATCH EXISTING, WHERE NECESSARY FOR PIPING AND FIXTURE REMOVAL & INSTALLATION.
- KITCHEN EQUIPMENT FURNISHED BY KITCHEN EQUIPMENT CONTRACTOR - PLUMBING CONTRACTOR SHALL MAKE FINAL CONNECTIONS TO UTILITIES REQUIRED AND PROVIDE PIPING, STOPS, WATER HAMMER ARRESTERS, TRAPS AND FITTINGS FOR EQUIPMENT TO BE IN OPERATIONAL ORDER. COORDINATE WITH KITCHEN EQUIPMENT SUPPLIER FOR CONNECTIONS AND LOCATIONS. SEE KITCHEN EQUIPMENT CONNECTION SCHEDULE FOR RESPONSIBILITY OF WHO FURNISHES VACUUM BREAKERS AND PRESSURE REDUCING VALVES.
- PVC PIPING SHALL NOT BE INSTALLED IN ANY RETURN AIR PLENUM UNLESS THE PIPING IS INSTALLED IN A PRE-APPROVED RATED ASSEMBLY.
- PROVIDE ACCESSIBLE SHUTOFF VALVE INSIDE THE BUILDING FOR EACH WALL HYDRANT.
- CONTRACTOR SHALL COORDINATE ALL CONNECTIONS OF PLUMBING SYSTEMS WITH EXTERIOR SITE UTILITIES AND SERVICES PRIOR TO INSTALLING ANY PIPING ON THE INTERIOR. CONTRACTOR SHALL CONFIRM THAT ALL INTERIOR PIPE INVERTS AND PIPE INVERTS AT THE 5' LINE MATCH EXTERIOR PIPE INVERTS, PRIOR TO INSTALLING ANY INTERIOR PIPING BELOW FLOOR.

NOTICE:  
DO NOT SCALE DRAWINGS. VERIFY ALL DIMENSIONS AND CLEARANCES FROM ARCHITECTURAL, STRUCTURAL, SHOP AND OTHER APPROPRIATE DRAWINGS OR AT SITE. LAY OUT AND COORDINATE ALL WORK PRIOR TO INSTALLATION TO PROVIDE CLEARANCES REQUIRED FOR OPERATION, MAINTENANCE, AND CODES. VERIFY NON-INTERFERENCE WITH OTHER WORK. DO NOT FABRICATE PRIOR TO VERIFICATION OF CLEARANCES FOR ALL TRADES. THIS NOTICE APPLIES TO ALL MECHANICAL / PLUMBING PLANS.

MECHANICAL	
Sheet Number	Sheet Name
MECHANICAL	
M0.0	MECHANICAL SYMBOLS
M0.1	MECHANICAL SPECS
M0.2	MECHANICAL COM CHECK
M1.1A	BUILDING A PLUMBING
M1.1B	BUILDING B PLUMBING
M6.1	PLUMBING DETAILS
M7.1	PLUMBING SCHEDULES
Grand total: 7	

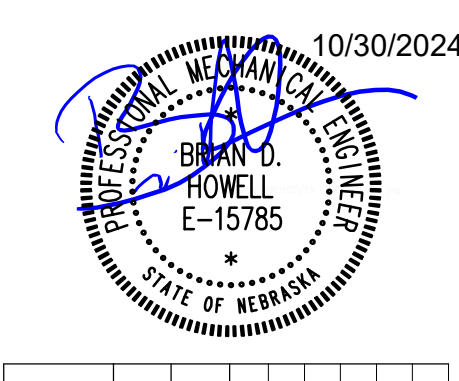

MECHANICAL SYMBOLS		REVISIONS	
No.	Description	Date	

# Contractor Storage Bays

McGregor Interests  
PIN 1729720452, Bennington, NE 68007



**Paul J. Kelly**  
Architect  
440 North 61st Street  
Omaha, Nebraska 68132  
(402) 320 - 4131  
pkjarchitecture.com

# M0.0

Project No







COMcheck Software Version COMcheckWeb  
**Interior Lighting Compliance Certificate**

**Project Information**

Energy Code: 2018 IECC  
 Project Title: CONTRACTOR BAYS  
 Project Type: New Construction

Construction Site: \_\_\_\_\_ Owner/Agent: \_\_\_\_\_ Designer/Contractor: \_\_\_\_\_

**Additional Efficiency Package(s)**

Credits: 1.0 Required 0.0 Proposed

**Allowed Interior Lighting Power**

A Area Category	B Floor Area (ft2)	C Allowed Watts / ft2	D Allowed Watts
1-Warehouse Storage:Smaller, Hand-Carried Items	30000	0.69	20700
Allowance: Decorative Appearance (not lobbies) / Fix. ID: L1	28000 (a)	0.75	21000 (b)
Total Allowed Watts =			41700

(a) Area claimed must not exceed the illuminated area permitted for this allowance type.  
 (b) Allowance is (B x C) or the actual wattage of the fixtures given in Section 2, whichever is less.

**Proposed Interior Lighting Power**

A Fixture ID : Description / Lamp / Wattage Per Lamp / Ballast	B Lamps/ Fixture	C # of Fixture	D Watt. (C X D)	E
1-Warehouse Storage:Smaller, Hand-Carried Items				
LED: L1: LED HEXAGON LIGHT: LED Other Fixture Unit 125W:	1	24	1700	40800
LED: D1: 6" LED DOWNLIGHT: LED PAR 15W:	1	48	13	624
Total Proposed Watts =				41424

Interior Lighting PASSES: Design 1% better than code

**Interior Lighting Compliance Statement**

Compliance Statement: The proposed interior lighting design represented in this document is consistent with the building plans, specifications, and other calculations submitted with this permit application. The proposed interior lighting systems have been designed to meet the 2018 IECC requirements in COMcheck-Version COMcheckWeb and to comply with any applicable mandatory requirements listed in the Inspection Checklist.

Brian Howell, PE - Project Engineer  10/15/2024  
 Name - Title Signature Date

Project Title: CONTRACTOR BAYS Report date: 10/15/24  
 Data filename: \_\_\_\_\_ Page 1 of 12

COMcheck Software Version COMcheckWeb  
**Exterior Lighting Compliance Certificate**

**Project Information**

Energy Code: 2018 IECC  
 Project Title: CONTRACTOR BAYS  
 Project Type: New Construction  
 Exterior Lighting Zone: 2 (Light industrial area with limited nighttime use (LZ2))

Construction Site: \_\_\_\_\_ Owner/Agent: \_\_\_\_\_ Designer/Contractor: \_\_\_\_\_

**Allowed Exterior Lighting Power**

A Area/Surface Category	B Quantity	C Allowed Watts /	D Tradable Wattage	E Allowed Watts (B X C)
Parking area	48543 ft2	0.04	Yes	1942
Entry canopy	216 ft2	0.25	Yes	54
Total Tradable Watts (a) =				1996
Total Allowed Watts =				1996
Total Allowed Supplemental Watts (b) =				400

(a) Wattage tradeoffs are only allowed between tradable areas/surfaces.  
 (b) A supplemental allowance equal to 400 watts may be applied toward compliance of both non-tradable and tradable areas/surfaces.

**Proposed Exterior Lighting Power**

A Fixture ID : Description / Lamp / Wattage Per Lamp / Ballast	B Lamps/ Fixture	C # of Fixture	D Watt. (C X D)	E
Parking area (48543 ft2): Tradable Wattage				
LED: WP1: LED WALL PACK: LED Roadway-Parking Unit 42W:	1	36	50	1800
Entry canopy (216 ft2): Tradable Wattage				
LED: WP2: LED EGRESS LIGHT: LED Other Fixture Unit 25W:	1	26	21	546
Total Tradable Proposed Watts =				2346

Exterior Lighting PASSES: Design 2% better than code

**Exterior Lighting Compliance Statement**

Compliance Statement: The proposed exterior lighting design represented in this document is consistent with the building plans, specifications, and other calculations submitted with this permit application. The proposed exterior lighting systems have been designed to meet the 2018 IECC requirements in COMcheck-Version COMcheckWeb and to comply with any applicable mandatory requirements listed in the Inspection Checklist.

Brian Howell, PE - Project Engineer  10/15/2024  
 Name - Title Signature Date

Project Title: CONTRACTOR BAYS Report date: 10/15/24  
 Data filename: \_\_\_\_\_ Page 2 of 12

COMcheck Software Version COMcheckWeb  
**Mechanical Compliance Certificate**

**Project Information**

Energy Code: 2018 IECC  
 Project Title: CONTRACTOR BAYS  
 Location: Bennington, Nebraska  
 Climate Zone: 5a  
 Project Type: New Construction

Construction Site: \_\_\_\_\_ Owner/Agent: \_\_\_\_\_ Designer/Contractor: \_\_\_\_\_

**Additional Efficiency Package(s)**

Credits: 1.0 Required 0.0 Proposed

**Mechanical Systems List**

**Quantity System Type & Description**

- 24 HVAC System (Unknown w/ Perimeter System):  
 Heating: 1 each - Unit Heater, Electric, Capacity = 34 kBtu/h  
 No minimum efficiency requirement applies  
 Fan System: FAN SYSTEM UH -- Compliance (Motor nameplate HP and fan efficiency method) : Passes
- Fans:  
 FAN 3 Supply, Constant Volume, 650 CFM, 0.2 motor nameplate hp, 76.0 fan efficiency grade, 78.0 total fan efficiency, 74.0 design fan efficiency
- 24 Water Heater:  
 Electric Instantaneous Water Heater, Capacity: 1 gallons  
 No minimum efficiency requirement applies

**Mechanical Compliance Statement**

Compliance Statement: The proposed mechanical design represented in this document is consistent with the building plans, specifications, and other calculations submitted with this permit application. The proposed mechanical systems have been designed to meet the 2018 IECC requirements in COMcheck-Version COMcheckWeb and to comply with any applicable mandatory requirements listed in the Inspection Checklist.

Brian Howell, PE - Project Engineer  10/15/2024  
 Name - Title Signature Date

Project Title: CONTRACTOR BAYS Report date: 10/15/24  
 Data filename: \_\_\_\_\_ Page 3 of 12

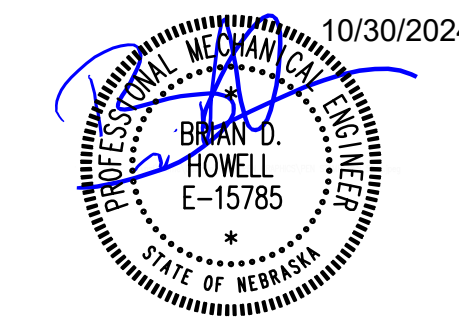

MECHANICAL COM CHECK		REVISIONS	
No.	Description	Date	

**Contractor Storage Bays**  
 McGregor Interests  
 PIN 1729720452, Bennington, NE 68007

  
**Paul J. Kelly**  
 Architecture  
 440 North 61st Street  
 Omaha, Nebraska 68132  
 (402) 320 - 4131  
 pjkararchitecture.com



COPYRIGHT BDH#: 24030  
 This document and the information contained may not be reproduced or excerpted from without the express written permission of BDH Engineering, LLC. Unauthorized copying, disclosure or construction use are prohibited by the copyright law.

**M0.2**  
 Project No. 24-021-01  
 Date 7 October 2024



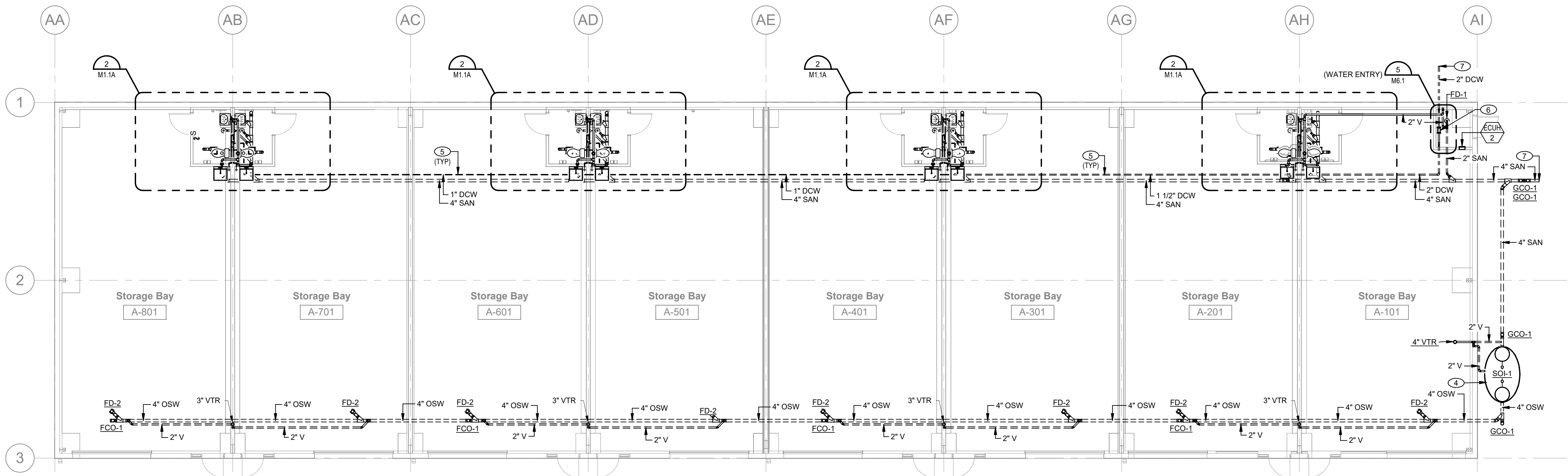

1 BUILDING A PLUMBING PLAN  
 1/8" = 1'-0"

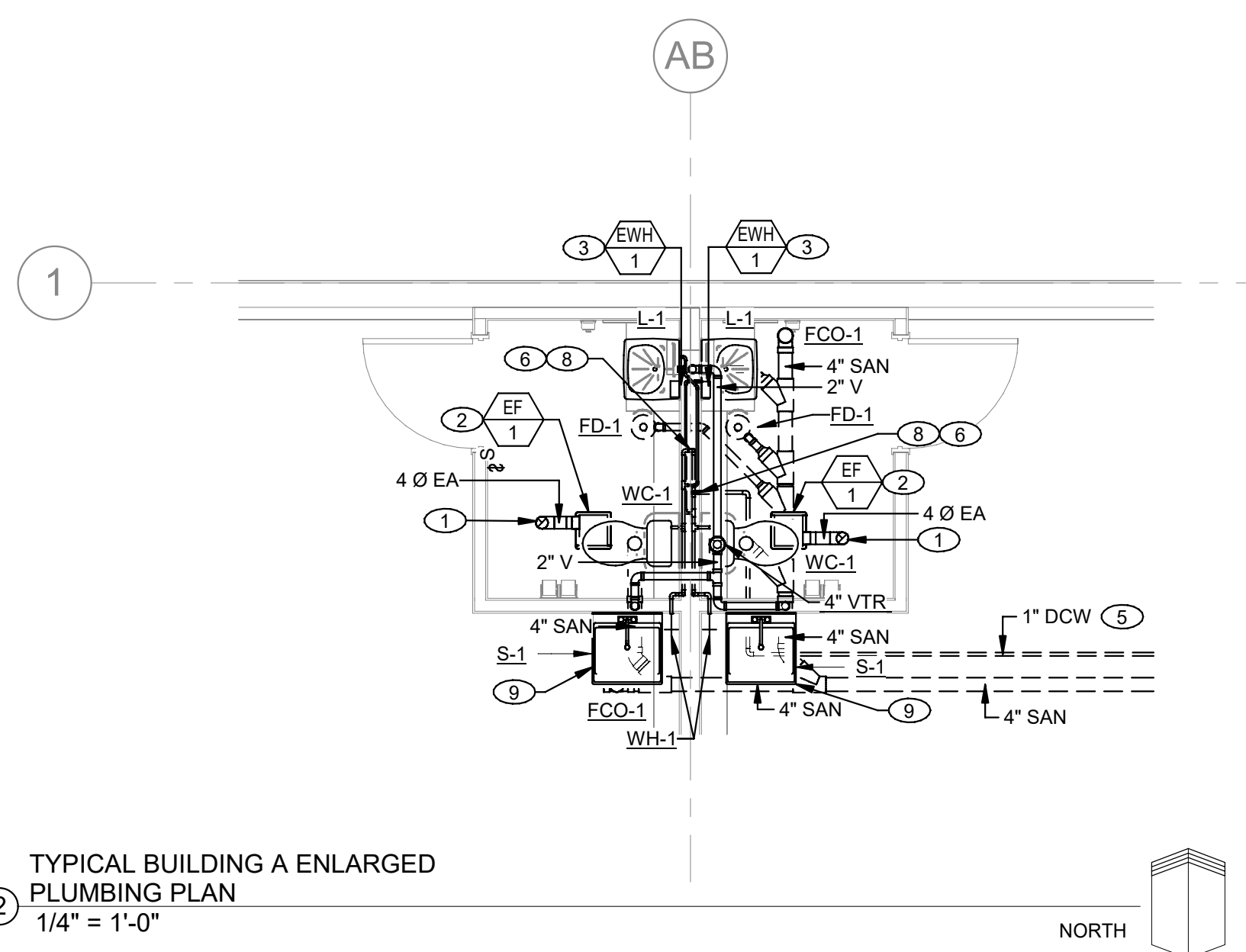
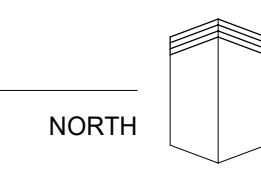

2 TYPICAL BUILDING A ENLARGED PLUMBING PLAN  
 1/4" = 1'-0"

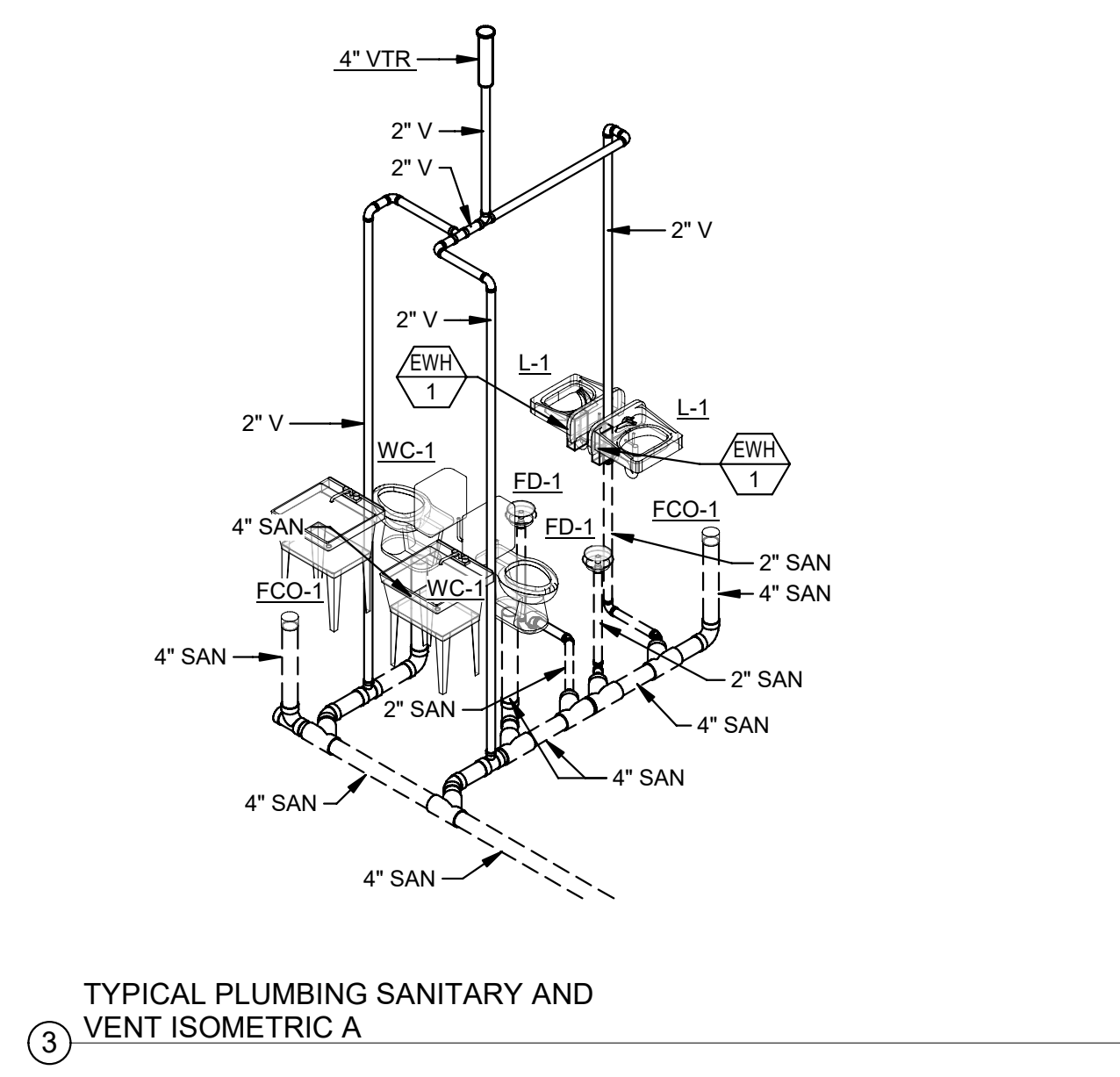

3 TYPICAL PLUMBING SANITARY AND VENT ISOMETRIC A

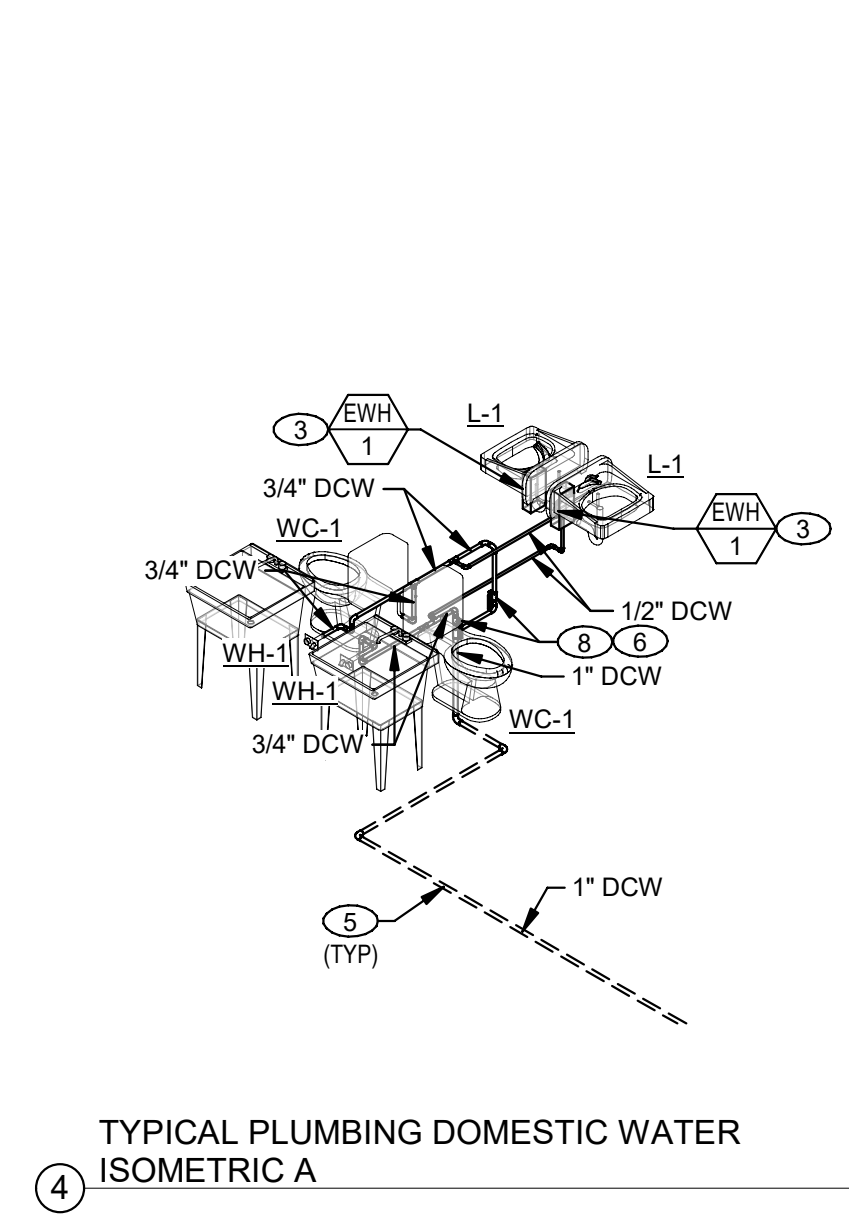

4 TYPICAL PLUMBING DOMESTIC WATER ISOMETRIC A

**PLUMBING NOTES:**

- A. SEE SHEET M0.0 FOR MECHANICAL SYMBOLS LEGEND AND GENERAL PLUMBING NOTES.
- B. SEE PLUMBING FIXTURE SCHEDULE ON M7.1 FOR BRANCH PIPE SIZES FROM MAIN TO FIXTURES UNLESS OTHERWISE NOTED.
- C. SEE SANITARY AND VENT ISOMETRIC ON SHEET M5.1 FOR ADDITIONAL PIPE SIZES.
- D. SEE DOMESTIC WATER ISOMETRIC ON SHEET M5.2 FOR ADDITIONAL PIPE SIZES.
- E. SUPPORT PIPING FROM STRUCTURE AS REQUIRED. SEE PIPE SUPPORT DETAIL FOR ADDITIONAL INFORMATION.

**KEYNOTES**

No.	Description
1	ROUTE 4" FAN EXHAUST UP THROUGH ROOF. TERMINATE WITH ROOF VENT HOOD SUITABLE FOR METAL ROOF APPLICATION.
2	INSTALL 75 CFM EXHAUST FAN IN CEILING FAN TO BE CONTROLLED THROUGH BATHROOM LIGHT SWITCH. REFER TO ELECTRICAL FOR MORE INFORMATION.
3	INSTALL ELECTRIC INSTANTANEOUS WATER HEATER UNDER SINK. COORDINATE WITH ELECTRICAL.
4	INSTALL SAND OIL INTERCEPTOR PER MANUFACTURERS RECOMMENDATIONS. EXTEND MANHOLE OPENINGS TO GRADE LEVEL.
5	DOMESTIC WATER LINES TO BE ROUTED UNDER SLAB. PROVIDE FOAM SLEEVE FOR ALL PENETRATIONS THROUGH THE SLAB TO PREVENT PIPE DAMAGE.
6	PROVIDE BID BREAKOUT PRICE FOR PLUMBER TO INSTALL SUB METER ON WATER LINE FOR EACH CONTRACTOR BAY. METER TO BE DAE AS200U-75P WATER METER WITH PULSE OUTPUT. 3/4" NPT COUPLINGS, MEASURING IN GALLONS.
7	SEE CIVIL FOR CONTINUATION.
8	ROUTE DCW UP FROM FLOOR AND PROVIDE 3/4" BALL VALVE FOR ISOLATION OF RESTROOM GROUP. BALL VALVE TO BE ACCESSIBLE WITHIN WALL. PROVIDE LOCKABLE ACCESS DOOR FOR ACCESS TO VALVE. ROUTE 3/4" DCW TO RESTROOM GROUP.
9	PROVIDE ALTERNATE PRICE TO INSTALL UTILITY SINK IN EACH BAY IN PLACE OF THE WALL HYDRANT. INSTALL ALL PIPING ON THE WARM SIDE OF WALL INSULATION.

**BUILDING A PLUMBING REVISIONS**

No.	Description	Date

**Contractor Storage Bays**  
 McGregor Interests  
 PIN 1729720452, Bennington, NE 68007



**Paul J. Kelly  
 Architecture**  
 440 North 61st Street  
 Omaha, Nebraska 68132  
 (402) 320-4131  
 pjarchitecture.com



**BDH  
 ENGINEERING**  
 BDH Engineering  
 440 Regency Parkway,  
 Suite 135  
 Omaha, NE 68114  
 bdhengineer.com  
 CA-4258

COPYRIGHT BDH# 24030

This document and the information contained may not be reproduced or excerpted from without the express written permission of BDH Engineering, LLC. Unauthorized copying, disclosure or construction use are prohibited by the copyright law.

**M.I.A**

Project No. 24-021-01  
 Date 7 October 2024



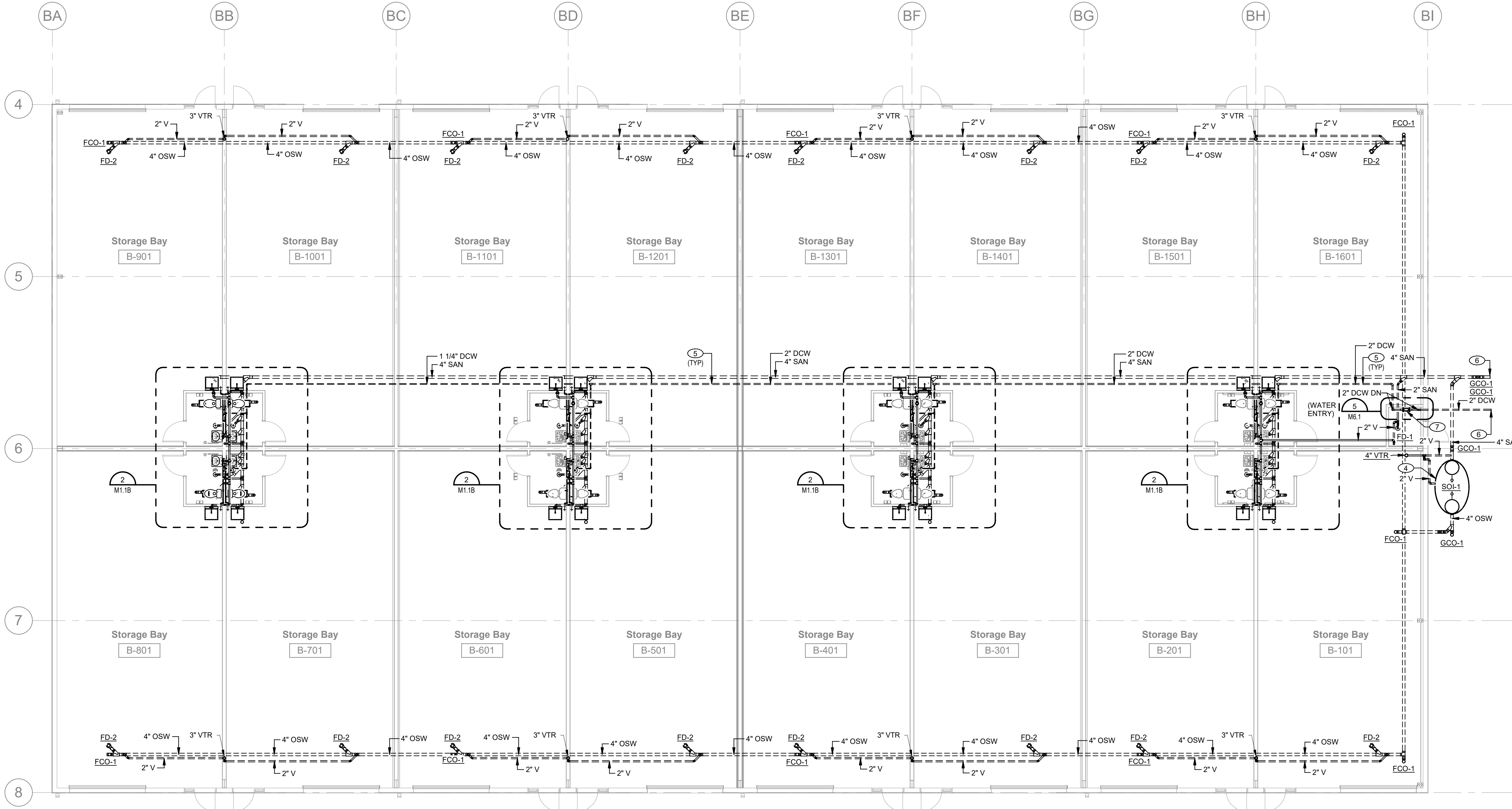

1 BUILDING B PLUMBING PLAN  
1/8" = 1'-0"

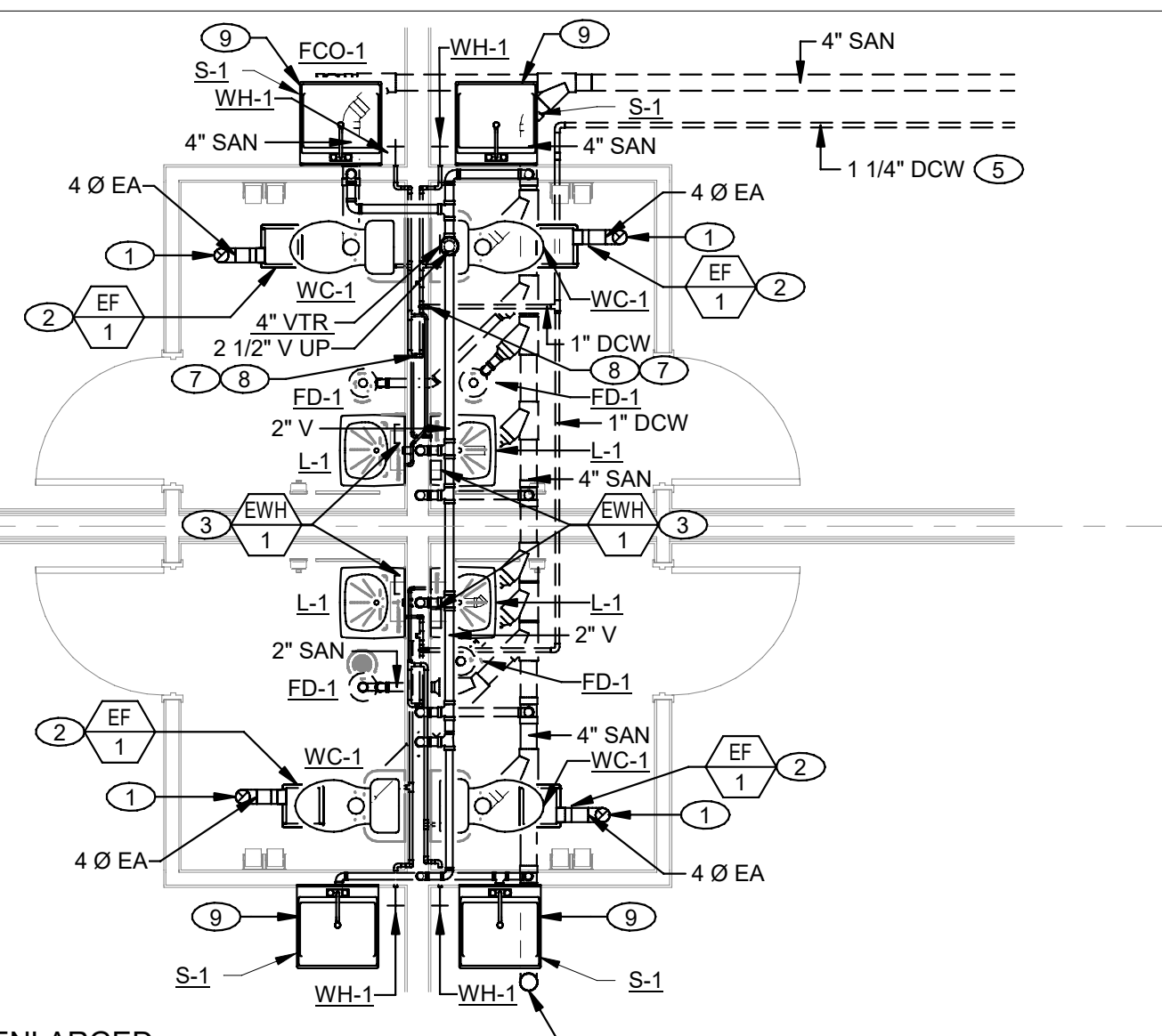

2 TYPICAL BUILDING B ENLARGED PLUMBING PLAN  
1/4" = 1'-0"

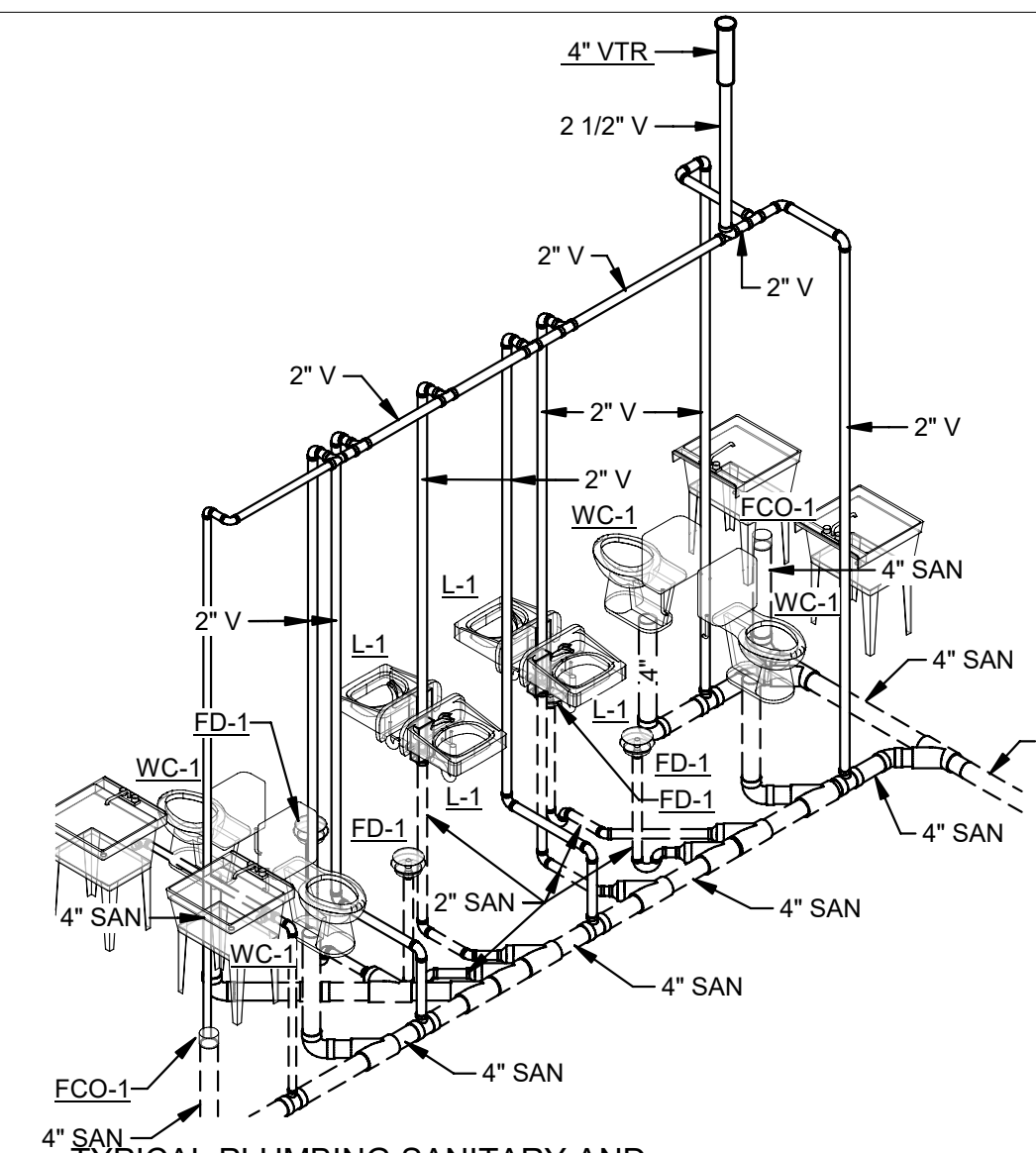

3 TYPICAL PLUMBING SANITARY AND VENT ISOMETRIC B

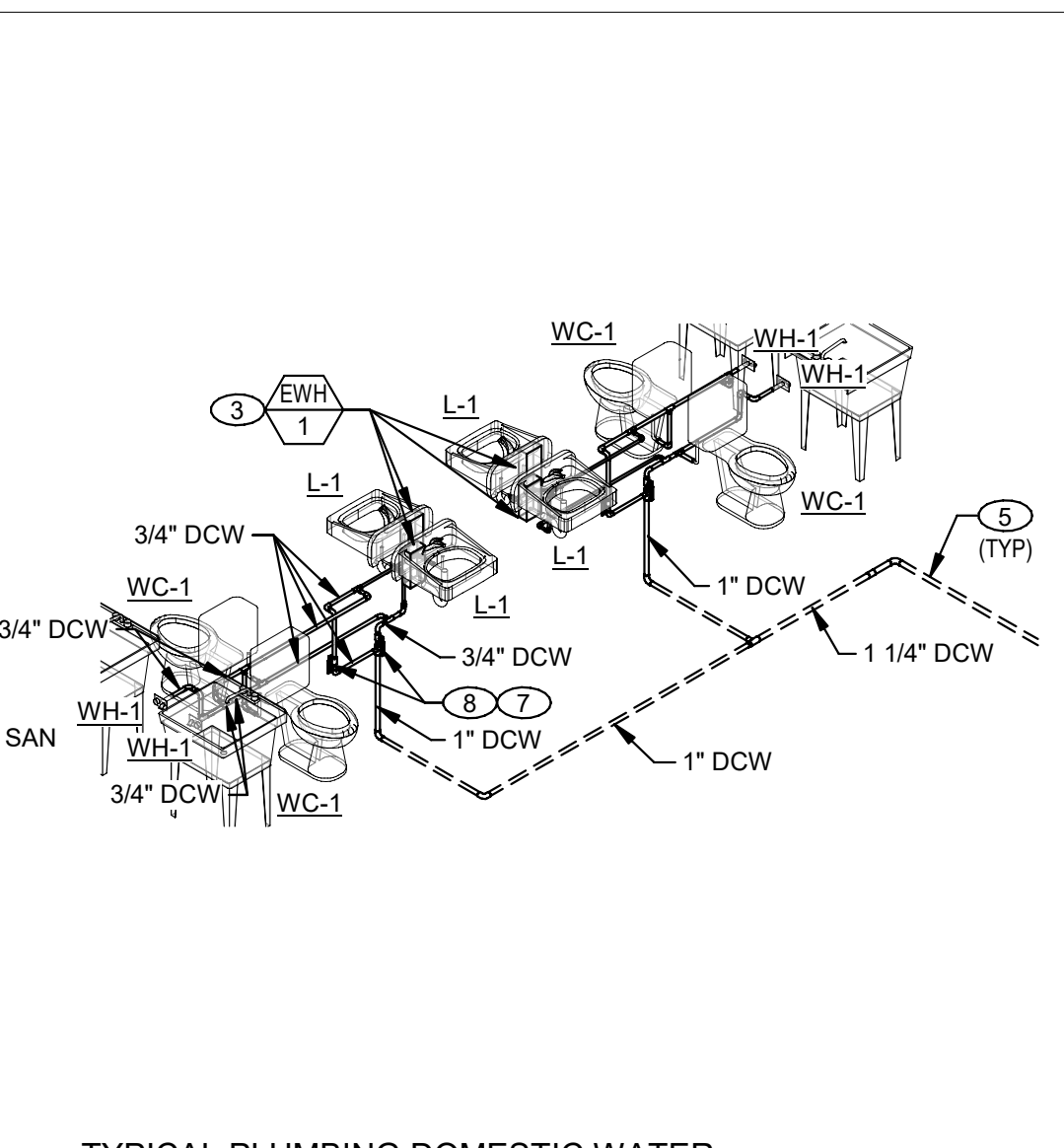

4 TYPICAL PLUMBING DOMESTIC WATER ISOMETRIC B

KEYNOTES	
1	ROUTE 4" FAN EXHAUST UP THROUGH ROOF. TERMINATE WITH ROOF VENT HOOD SUITABLE FOR METAL ROOF APPLICATION.
2	INSTALL 75 CFM EXHAUST FAN IN CEILING FAN TO BE CONTROLLED THROUGH BATHROOM LIGHT SWITCH. REFER TO ELECTRICAL FOR MORE INFORMATION.
3	INSTALL ELECTRIC INSTANTANEOUS WATER HEATER UNDER SINK. COORDINATE WITH ELECTRICAL.
4	INSTALL SAND OIL INTERCEPTOR PER MANUFACTURER'S RECOMMENDATIONS. EXTEND MANHOLE OPENINGS TO GRADE LEVEL.
5	DOMESTIC WATER LINES TO BE ROUTED UNDER SLAB. PROVIDE FOAM SLEEVE FOR ALL PENETRATIONS THROUGH THE SLAB TO PREVENT PIPE DAMAGE.
6	SEE CIVIL FOR CONTINUATION.
7	PROVIDE BID BREAKOUT PRICE FOR PLUMBER TO INSTALL SUB METER ON WATER LINE FOR EACH CONTRACTOR BAY. METER TO BE DAE AS200U-75P WATER METER WITH PULSE OUTPUT, 3/4" NPT COUPLINGS, MEASURING IN GALLONS.
8	ROUTE DCW UP FROM FLOOR AND PROVIDE 3/4" BALL VALVE FOR ISOLATION OF RESTROOM GROUP. BALL VALVE TO BE ACCESSIBLE WITHIN WALL. PROVIDE LOCKABLE ACCESS DOOR FOR ACCESS TO VALVE. ROUTE 3/4" DCW TO RESTROOM GROUP.
9	PROVIDE ALTERNATE PRICE TO INSTALL UTILITY SINK IN EACH BAY IN PLACE OF THE WALL HYDRANT. INSTALL ALL PIPING ON THE WARM SIDE OF WALL INSULATION.

- PLUMBING NOTES:**
- A. SEE SHEET M0.0 FOR MECHANICAL SYMBOLS LEGEND AND GENERAL PLUMBING NOTES.
  - B. SEE PLUMBING FIXTURE SCHEDULE ON M7.1 FOR BRANCH PIPE SIZES FROM MAIN TO FIXTURES UNLESS OTHERWISE NOTED.
  - C. SEE SANITARY AND VENT ISOMETRIC ON SHEET M5.1 FOR ADDITIONAL PIPE SIZES.
  - D. SEE DOMESTIC WATER ISOMETRIC ON SHEET M5.2 FOR ADDITIONAL PIPE SIZES.
  - E. SUPPORT PIPING FROM STRUCTURE AS REQUIRED. SEE PIPE SUPPORT DETAIL FOR ADDITIONAL INFORMATION.

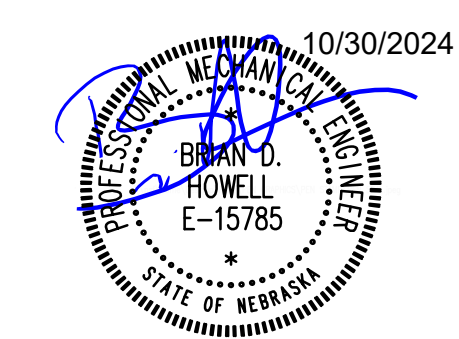

BUILDING B PLUMBING REVISIONS		Date
No.	Description	

**Contractor Storage Bays**  
 McGregor Interests  
 PIN 1729720452, Bennington, NE 68007

**Paul J. Kelly**  
 Architecture  
 440 North 61st Street  
 Omaha, Nebraska 68132  
 (402) 320-4131  
 pjkarhitecture.com

**MI.IB**  
 Project No. 24-021-01  
 Date 7 October 2024

**BDH ENGINEERING**  
 BDH Engineering  
 440 Regency Parkway,  
 Suite 135  
 Omaha, NE 68114  
 bdhengineer.com  
 CA-4258  
 COPYRIGHT BDH# 24030  
 This document and the information contained may not be reproduced or excerpted from without the express written permission of BDH Engineering, LLC. Unauthorized copying, disclosure or construction use are prohibited by the copyright law.



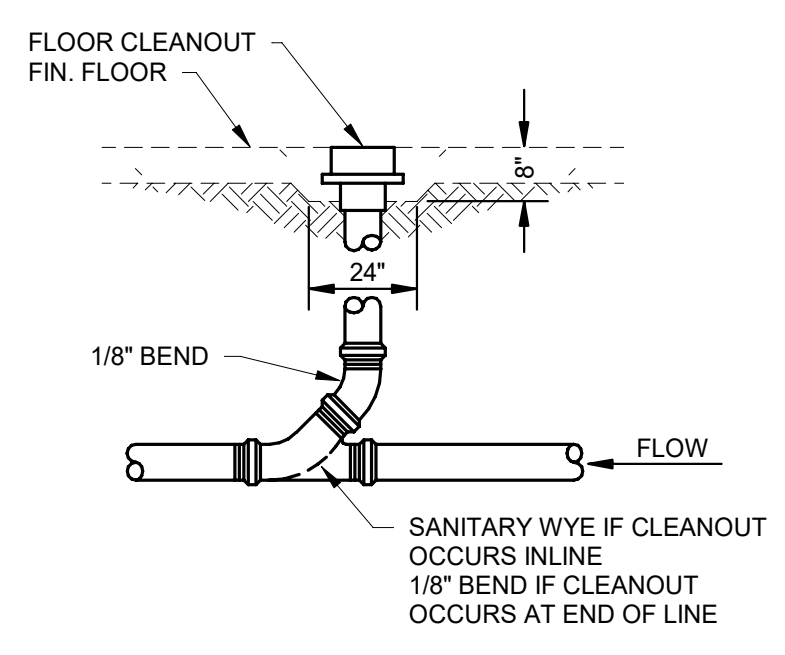

**1 FLOOR CLEANOUT DETAIL**  
 M6.1 NOT TO SCALE

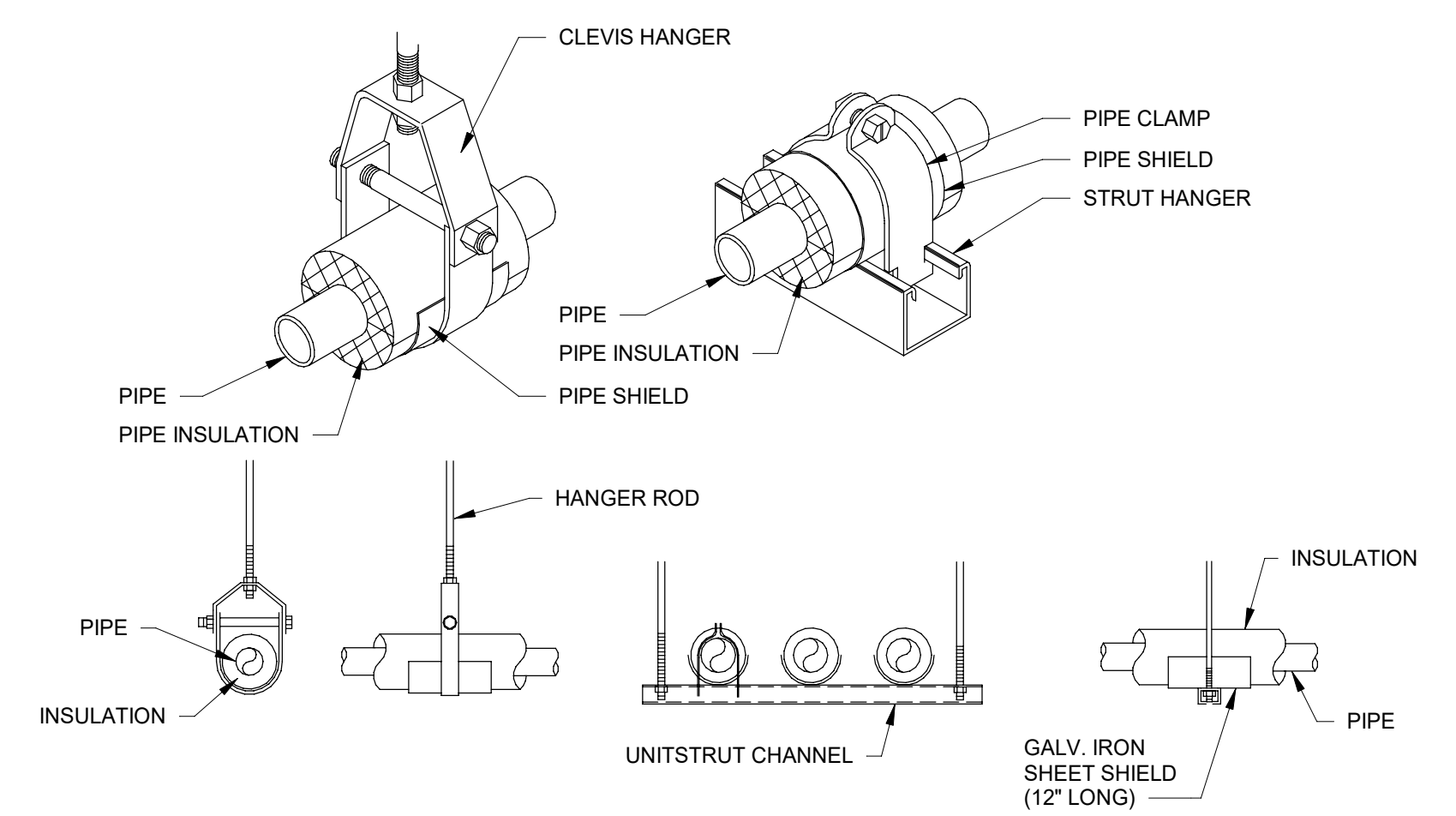

- NOTES:**
1. ATTACH SUPPORTS FOR ALL PIPING SUSPENDED FROM THE STEEL STRUCTURE TO THE TOP CORD OF JOISTS OF BEAMS. PROVIDE COPPER OR PLASTIC COATED HANGERS FOR NON-INSULATED COPPER PIPE.
  2. PROVIDE AND INSTALL B-LINE OR ACCEPTABLE INSULATED GALVANIZED STEEL JACKET AND HANGER, STRUT MOUNTED CLAMP AND PIPE SUPPORT LOCATIONS.

**3 PIPE SUPPORT DETAIL**  
 M6.1 NOT TO SCALE

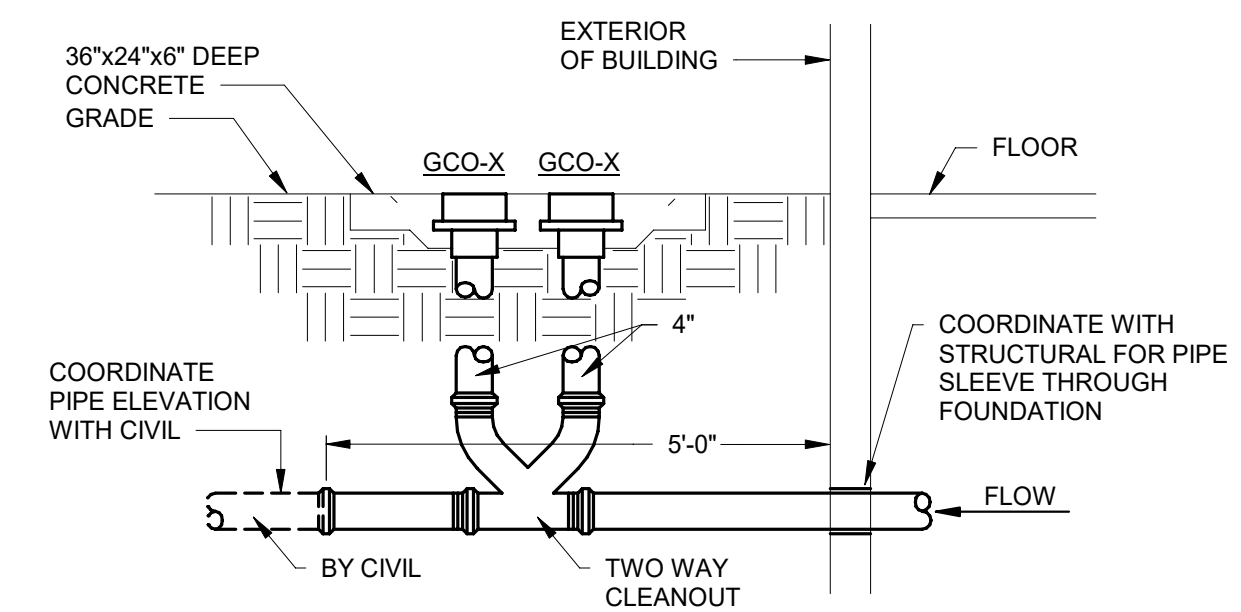

**2 DOUBLE GRADE CLEANOUT**  
 M6.1 NOT TO SCALE

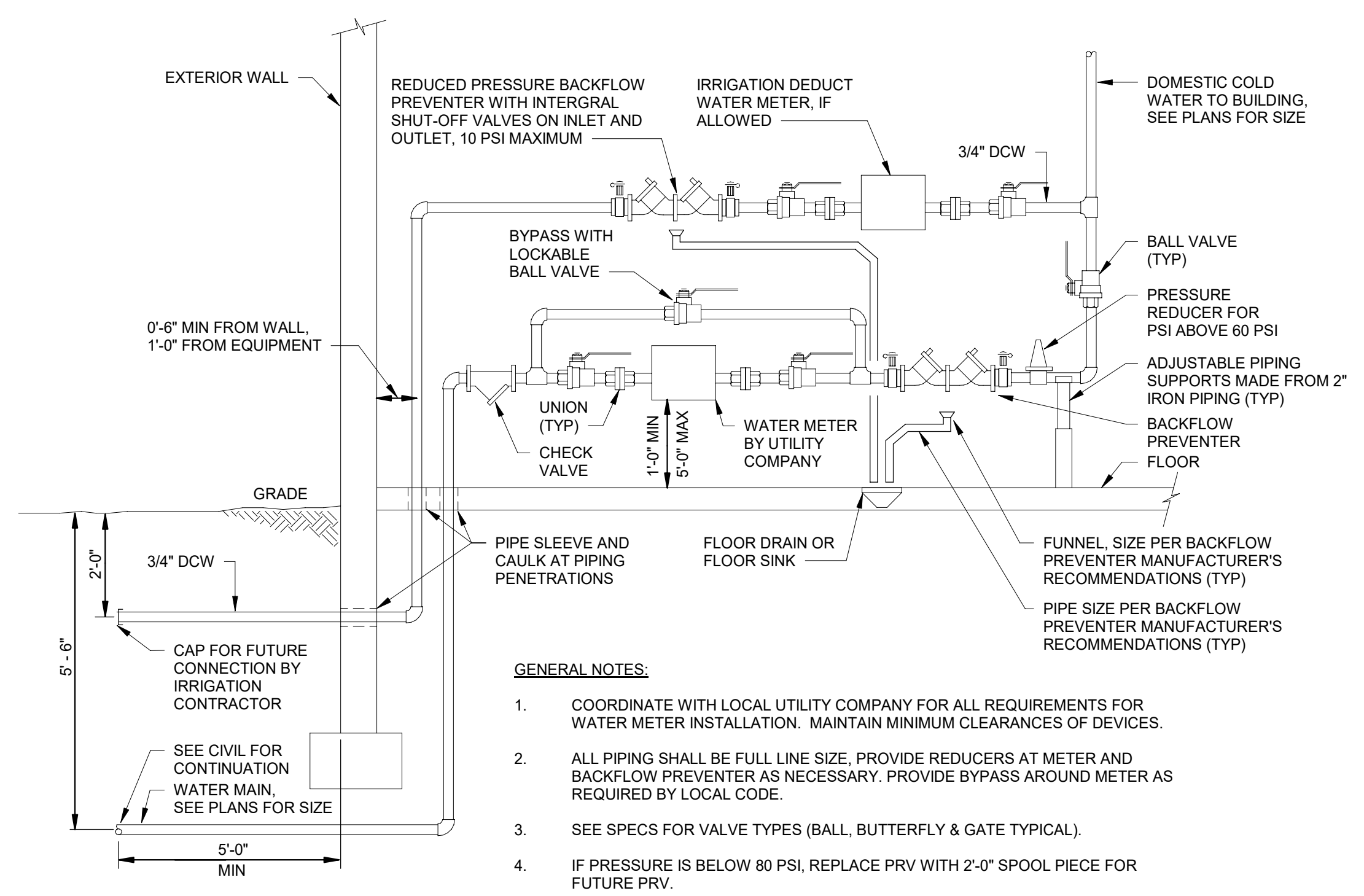

- GENERAL NOTES:**
1. COORDINATE WITH LOCAL UTILITY COMPANY FOR ALL REQUIREMENTS FOR WATER METER INSTALLATION. MAINTAIN MINIMUM CLEARANCES OF DEVICES.
  2. ALL PIPING SHALL BE FULL LINE SIZE, PROVIDE REDUCERS AT METER AND BACKFLOW PREVENTER AS NECESSARY. PROVIDE BYPASS AROUND METER AS REQUIRED BY LOCAL CODE.
  3. SEE SPECS FOR VALVE TYPES (BALL, BUTTERFLY & GATE TYPICAL).
  4. IF PRESSURE IS BELOW 80 PSI, REPLACE PRV WITH 2'-0" SPOOL PIECE FOR FUTURE PRV.

**5 WATER SERVICE ENTRY DETAIL WITH IRRIGATION**  
 M6.1 NOT TO SCALE

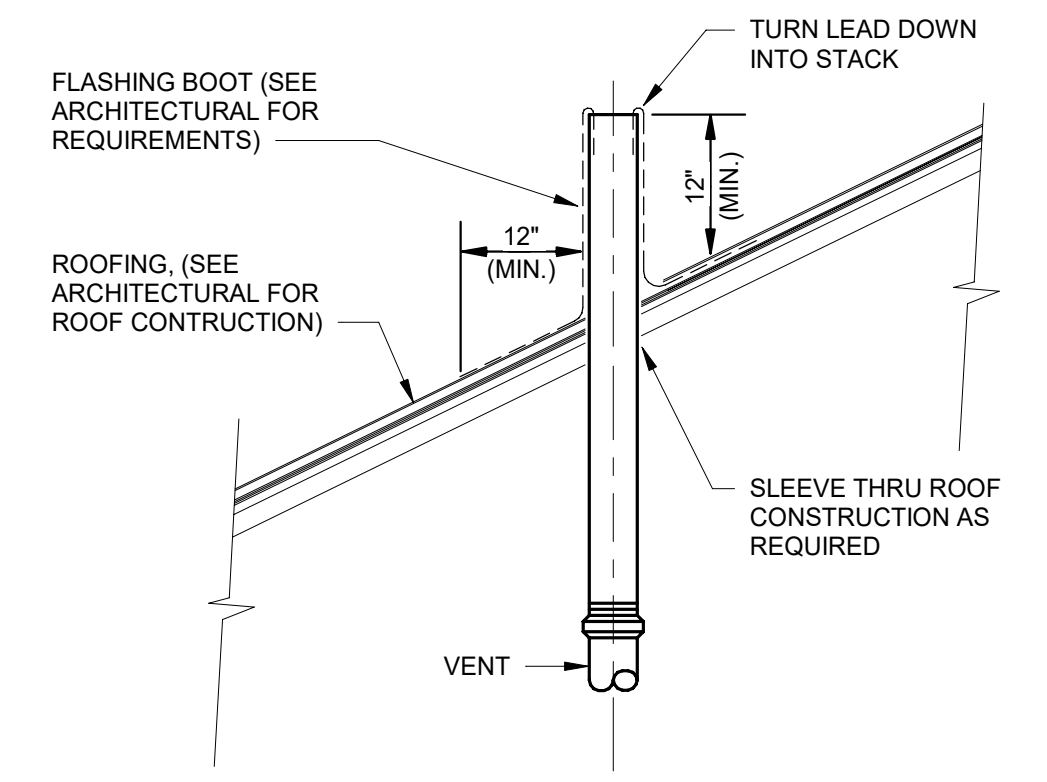

**4 VENT THRU SLOPED ROOF DETAIL**  
 M6.1 NOT TO SCALE

DETAILS SHALL BE USED  
 IN ALL APPLICABLE  
 SITUATIONS WHETHER  
 SPECIFICALLY CALLED  
 OUT OR NOT

**BDH** ENGINEERING  
 BDH Engineering  
 440 Regency Parkway,  
 Suite 135  
 Omaha, NE 68114  
 bdhengineer.com  
 CA-4258  
 COPYRIGHT BDH# 24030  
 This document and the information contained may not be reproduced or excerpted from without the express written permission of BDH Engineering, LLC. Unauthorized copying, disclosure or construction use are prohibited by the copyright law.

**PLUMBING DETAILS**

REVISIONS		Date
No.	Description	

**Contractor Storage Bays**  
 McGregor Interests  
 PIN 1729720452, Bennington, NE 68007

**PK**  
 Paul J. Kelly  
 Architecture  
 440 North 61st Street  
 Omaha, Nebraska 68132  
 (402) 320-4131  
 pjkararchitecture.com

**M6.1**  
 Project No. 24-021-01  
 Date 7 October 2024  
 Print on 22" x 34" format for proper scale



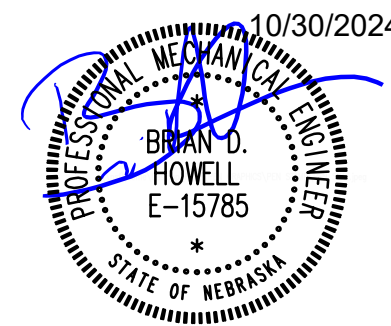

10/15/2024 11:35:56 PM

DOMESTIC WATER HEATER SCHEDULE (ELECTRIC)						
MARK	CAPACITY (GAL)	FLOW RATE (GPM)	TEMP. RISE (°F)	ELEC INPUT (KW)	MANUFACTURER & MODEL NO.	REMARKS
EWH-1	-	0.5	56	4.1	EEMAX SPEX4208T	1

REMARKS:  
1. PROVIDE WITH UNIT MOUNTED DISCONNECT AND DIGITAL TEMPERATURE SETTING

PLUMBING FIXTURE CONNECTION SCHEDULE											
LABEL MARK	FIXTURE	MANUFACTURER	MODEL	DESCRIPTION	ACCESSORIES	URL	MINIMUM CONNECTION SIZE				REMARKS
							WASTE	VENT	HOT WATER	COLD WATER	
FCO-1	FLOOR CLEANOUT	J.R. SMITH	4020 SERIES	FINISHED FLOOR CLEANOUT WITH ROUND NICKEL BRONZE TOP. DUCO CAST IRON CLEANOUT WITH ROUND ADJUSTABLE SCORIATED SECURED NICKEL BRONZE TOP. INTERNAL TAPER THREAD AND BRONZE PLUG. VERIFY FLOOR FINISH PRIOR TO ORDERING.	--	<a href="https://www.jrsmith.com/finished-floor-cleanouts-4020-4034">https://www.jrsmith.com/finished-floor-cleanouts-4020-4034</a>	4"	--	--	--	1
FD-1	FLOOR DRAIN (ROUND)	J.R. SMITH	2050-A-NB (ROUND STRAINER)	ROUND FLOOR OR SHOWER DRAIN WITH ADJUSTABLE STRAINER HEAD. DUCO CAST IRON BODY WITH FLASHING COLLAR AND ADJUSTABLE FLASHING TYPE NICKEL BRONZE STRAINER. LIGHT DUTY LOAD RATING.	--	<a href="https://www.jrsmith.com/floor-drain-2050">https://www.jrsmith.com/floor-drain-2050</a>	2"	2"	--	--	--
FD-2	FLOOR DRAIN (ROUND)	J.R. SMITH	2110-M	ROUND FLOOR DRAIN WITH ADJUSTABLE STRAINER HEAD. DUCO CAST IRON BODY WITH FLASHING COLLAR AND CAST IRON SLOTTED GRATE. MEDIUM DUTY LOAD RATING.	--	<a href="https://www.jrsmith.com/floor-drain-2110">https://www.jrsmith.com/floor-drain-2110</a>	4"	2"	--	--	--
GCO-1	GRADE CLEANOUT	J.R. SMITH	4880-U	DUCO CAST IRON DOUBLE FLANGED BODY WITH HEAVY DUTY SECURED SCORIATED CAST IRON COVER WITH LIFTING DEVICE. PROVIDE VANDAL PROOF SCREWS.	--	<a href="https://www.jrsmith.com/flanged-housing-4880">https://www.jrsmith.com/flanged-housing-4880</a>	4"	--	--	--	2
L-1	LAVATORY (WALL MOUNT)	AMERICAN STANDARD	LUCERNE	ADA WALL HUNG SINK WITH WALL HANGER. 18" X 21" X 8 5/8" VITREOUS CHINA D-SHAPED BOWL WITH ANTI-SPLASH RIM AND FRONT OVERFLOW. FAUCET HOLES ON 4" CENTERS.	ADA 4-INCH CENTERSET SINGLE-HANDLE BATHROOM POLISHED CHROME FAUCET. 1.2 GMP WITH LEVER HANDLE. AMERICAN STANDARD 7385.003 RELIANT 3 SINGLE CONTROL CENTERSET WITH INDEXED METAL LEVER HANDLE. GRID DRAIN. LESS POP-UP HOLE. PROVIDE TRUBRO P-TRAP PIPE COVERS.	<a href="https://www.americanstandard-us.com/commercial-wall-hung-sinks/lucerne%2%84%a2-wall-hung-sink-wit-h-4-inch-centerset/white-0355012020">https://www.americanstandard-us.com/commercial-wall-hung-sinks/lucerne%2%84%a2-wall-hung-sink-wit-h-4-inch-centerset/white-0355012020</a>	1 1/2"	1 1/4"	1/2"	1/2"	4, 5, 6
S-1	SERVICE SINK			UTILITYSERVICE SINK WITH 4 LEGS. PROVIDE AS BID ALTERNATE.	LONG REACH FAUCET WITH VACUUM BREAKER AND HOSE CONNECTION.		2"	1 1/2"	1/2"	1/2"	5
SOI-1	GREASE INTERCEPTOR	MIFAB BIG-O	BIG-75-O	HDPE ROTATIONAL MOLDED OIL INTERCEPTOR WITH FLOW RATING OF 75 GPM AND LIQUID HOLDING CAPACITY OF 140 GALLONS. UNIT SHALL INCLUDE: 3/8" UNIFORM WALL THICKNESS. DEEP SEAL TRAP COVERED BY LID. ADJUSTABLE LID SYSTEM. STAINLESS STEEL CALIBRATED ORIFICE PLATE (INTERNAL FLOW CONTROL). INTERNAL AIR RELIEF BY-PASS. ADJUSTABLE OIL DRAW-OFF ASSEMBLY (1 1/2") ON EACH SIDE. DOUBLE VENT CONNECTIONS (3") ON EACH SIDE. SAMPLE PORT ACCESS AND 4" NO HUB INLET AND OUTLET CONNECTIONS. COMPOSITE LIDS PROVIDES A WATER / GAS TIGHT SEAL AND HAS A MINIMUM OF 20,000 LBS. LOAD CAPACITY. THE LID IS DESIGNED IN ACCORDANCE WITH THE LOADING REQUIREMENTS OF AASHTO H20.	LID EXTENSION AS NEEDED TO BE FLUSH WITH GRADE.	<a href="https://mifab.com/products/big-o/#Technical_Documents_tab">https://mifab.com/products/big-o/#Technical_Documents_tab</a>	4"	2"	--	--	--
WC-1	WATER CLOSET (TANK - ADA)	AMERICAN STANDARD KOHLER	CADET PRO RIGHT HEIGHT HIGHLINE K-3611	ADA COMPLIANT, ELONGATED FLOOR MOUNT VITREOUS CHINA SIPHON JET WATER CLOSET. LOW CONSUMPTION (6.0 LPP/1.6 GPF) FULLY GLAZED 2" BALLPASS TRAPWAY. 11" x 9" WATER SURFACE. CLOSE COUPLED TANK. COLOR MATCHED TRIP LEVER.	COMMERCIAL WEIGHT SOLID PLASTIC OPEN FRONT LESS COVER FOR ELONGATED BOWL. LARGE INTEGRAL BUMPER SHALL BE COLOR-MATCHED MOLDED PLASTIC. HINGES TO FEATURE EXTERNAL CHECK AND INTERNAL SELF-SUSTAINING MECHANISMS IN BOTH HINGES. COLOR TO BE WHITE. CHURCH MODEL #285SSC.	<a href="https://lixil.cdn.celum.cloud/172117_as_us_bath_spec__215A%20(7102)_original.pdf">https://lixil.cdn.celum.cloud/172117_as_us_bath_spec__215A%20(7102)_original.pdf</a>	4"	2"	--	3/4"	5,6
WH-1	WALL HYDRANT	WOODFORD	19	3/4" FREEZELESS WALL HYDRANT WITH INTEGRAL ANTI-SIPHON VACUUM BREAKER-BACKFLOW PREVENTOR. 3/4" HOSE THREAD OUTLET. CHROME FINISH. VERIFY WALL THICKNESS PRIOR TO ORDERING WALL HYDRANT(S). WOODFORD #19 OR APPROVED EQUAL. <a href="https://www.woodfordmfg.com/WoodfordWall_Faucet_Pages/Model-19.html">https://www.woodfordmfg.com/WoodfordWall_Faucet_Pages/Model-19.html</a>	--		--	--	--	3/4"	--

- GENERAL NOTES:  
 A. PLUMBING FIXTURES SHALL BE OF ONE OF THE MANUFACTURER'S INDICATED AND IN ACCORDANCE WITH THE INFORMATION AND MANUFACTURER'S CATALOG NUMBERS INDICATED. WHERE MANUFACTURER'S CATALOG NUMBERS HAVE BEEN UPDATED OR DELETED, FIXTURES SHALL BE OF SIMILAR CONFIGURATION AND OF SIMILAR OR BETTER QUALITY THAN THAT INDICATED.  
 B. VERIFY ALL MOUNTING HEIGHTS OF PLUMBING FIXTURES PRIOR TO ORDERING EQUIPMENT. MOUNTING HEIGHTS SHALL BE AS INDICATED ON ARCHITECTURAL DRAWINGS AND COMPLY WITH ADA REQUIREMENTS.  
 C. VERIFY FIXTURE COLORS WITH ARCHITECT PRIOR TO ORDERING EQUIPMENT.  
 D. FOR ALL COUNTERTOP SINKS, CONTRACTOR SHALL COORDINATE WITH CABINET WORK TO INSURE THAT THE SINK WILL FIT IN CABINET PRIOR TO ORDERING FIXTURE.  
 E. FIXTURE DRAWINGS DEPICTED MAY NOT NECESSARILY BE AN ACCURATE DEPICTION OF ACTUAL MODELS DUE TO RECENT PRODUCT UPDATES.  
 F. ALL FIXTURE STOPS SHALL BE LOOSE KEY.  
 G. SIZE LISTED ON SCHEDULES APPLY TO ALL FIXTURES ON PROJECT UNLESS OTHERWISE NOTED.  
 H. SEE PLANS AND RISERS FOR ADDITIONAL INFORMATION.  
 I. INTALL PER MANUFACTURER'S RECOMMENDATIONS.

- REMARKS:  
 1. SEE FLOOR CLEANOUT DETAIL ON PLUMBING DETAIL SHEET FOR ADDITIONAL INFORMATION.  
 2. SEE DOUBLE GRADE CLEANOUT DETAIL ON PLUMBING DETAIL SHEET FOR ADDITIONAL INFORMATION.  
 3. SEE FLUSH VALVE ELEVATION DETAIL ON PLUMBING DETAIL SHEET FOR ADDITIONAL INFORMATION.  
 4. PROVIDE WALL CARRIER FOR BLOCK OR STUD CONSTRUCTION WITH CONCEALED ARMS, STRUCTURAL UPRIGHTS, BLOCK BASES, AND LEVELING AND SECURING SCREWS WITH ADJUSTABLE WALL PLATE. VERIFY WALL THICKNESS PRIOR TO ORDERING CARRIER(S).  
 5. COMPLETE WITH SOLID BRASS STOPS WITH ALL BRASS STEMS AND CHLORAMINE-CHLORINE RESISTANT WASHERS. CHLORAMINE-CHLORINE RESISTANT BRAIDED STAINLESS STEEL OR POLYMER FLEXIBLE CONNECTORS. CAST BRASS SOLID TOP OPEN GRID P.O. PLUG WITH 6" 17 GAUGE TAILPIECE WITH CAST BRASS LOCKNUT. HEAVY CAST BRASS ADJUSTABLE P-TRAP WITH 17 GA TUBULAR WALL BEND AND BRASS SLIP NUTS. (ALL BRASS MATERIALS SHALL BE CHROME PLATED).  
 6. FIXTURE SHALL COMPLY WITH ADA HANDICAPPED REQUIREMENTS WHEN INSTALLED PER MANUFACTURER'S RECOMMENDATIONS AND PER ADA REQUIREMENTS.

PLUMBING SCHEDULES	REVISIONS		Date
	No.	Description	

**Contractor Storage Bays**  
 McGregor Interests  
 PIN 1729720452, Bennington, NE 68007



**Paul J. Kelly**  
**Architecture**  
 440 North 61st Street  
 Omaha, Nebraska 68132  
 (402) 320 - 4131  
 pjkararchitecture.com

**M7.I**  
 Project No. 24-021-01  
 Date 7 October 2024



BDH Engineering  
 440 Regency Parkway,  
 Suite 135  
 Omaha, NE 68114  
 bdhengineer.com  
 CA-4258  
 COPYRIGHT BDH#: 24030  
 This document and the information contained may not be reproduced or excerpted from without the express written permission of BDH Engineering, LLC. Unauthorized copying, disclosure or construction use are prohibited by the copyright law.

Print on 22" x 34" format for proper scale







ELECTRICAL SPECIFICATIONS

A. GENERAL:

1. THE ELECTRICAL CONTRACTOR SHALL FURNISH ALL LABOR AND MATERIALS FOR THE INSTALLATION OF THE ELECTRICAL WORK.
2. ALL MATERIAL AND EQUIPMENT FURNISHED BY THE CONTRACTOR SHALL BE NEW.
3. THE INSTALLATION SHALL BE IN ACCORDANCE WITH THE REQUIREMENTS OF THE 2020 NATIONAL ELECTRICAL CODE (NEC) AND ALL INSPECTION AUTHORITIES HAVING JURISDICTION.
4. PROCURE AND DELIVER ALL LICENSES AND CERTIFICATES REQUIRED TO THE ARCHITECT. ALL INSPECTION AND POWER COMPANY FEES SHALL BE PAID BY THE CONTRACTOR.
5. COORDINATION:
  - a. COORDINATE WORK WITH THE WORK OF OTHER TRADES.
  - b. REFER TO ARCHITECTURAL FOR ALL PROCEDURAL AND CONTRACTING REQUIREMENTS AS WELL AS GENERAL REQUIREMENTS AND ANY OTHER SPECIFICATION SECTIONS THAT MAY AFFECT WORK INCLUDED IN THESE PLANS.
  - c. THE CONTRACTOR SHALL COORDINATE AND SCHEDULE ALL NECESSARY POWER OUTAGES WITH THE OWNER PRIOR TO PROCEEDING WITH SUCH WORK TO INSURE THAT OPERATIONS IN ADJACENT OCCUPIED PORTIONS OF THE BUILDING ARE NOT INTERRUPTED OR RESTRICTED WITHOUT PRIOR APPROVAL.
6. THE CONTRACTOR, BY THE ACCEPTANCE OF THIS SPECIFICATION AND THE SIGNING OF THE CONTRACT, ACKNOWLEDGES HIS ACQUAINTANCE WITH THE REQUIREMENTS AND GUARANTEES THE WORKMANSHIP, EQUIPMENT AND MATERIALS FOR A PERIOD OF ONE (1) YEAR FROM THE DATE OF FINAL ACCEPTANCE.
7. SHOP DRAWINGS:
  - a. SHOP DRAWINGS, CATALOG SHEETS AND MANUFACTURER'S DATA SHALL BE SUBMITTED ON OR BEFORE THIRTY DAYS AFTER AWARD OF CONTRACT. DATA SHALL BE SUFFICIENTLY COMPLETED TO PERMIT EVALUATION AND COMPARISON WITH SPECIFIED EQUIPMENT AND MATERIAL.
  - b. SUBMIT SHOP DRAWINGS FOR THE FOLLOWING: LUMINAIRES, LAMPS, DRIVERS, WIRING DEVICES, DISTRIBUTION PANELS, PANELBOARDS, SAFETY SWITCHES, LIGHTING CONTROL DEVICES, TELECOMMUNICATIONS, AND FIRE ALARM SYSTEM.
8. EXISTING CONDITIONS:
  - a. INASMUCH AS WORK UNDER THIS CONTRACT INCLUDES ADDING TO IN THE EXISTING BUILDING, IT SHALL BE THE RESPONSIBILITY OF EACH BIDDER TO FULLY INFORM HIMSELF OF ANY AND ALL CONDITIONS WHICH INFLUENCE OR ARE INFLUENCED BY WORK COMPLETED BY THESE SPECIFICATIONS AND ACCOMPANYING DRAWINGS. THE SUBMISSION OF A PROPOSAL BY ANY BIDDER WILL BE CONSTRUED AS AN ADMISSION BY HIM THAT HE HAS EXAMINED AND IS FULLY FAMILIAR WITH THE PREMISES AND ALL CONDITIONS THEREON AND ADJACENT THERETO, AND HAS INCLUDED IN THIS PROPOSAL A PROPER AND ADEQUATE AMOUNT TO COVER REARRANGEMENT OF OLD WORK FOR THE PROPER INSTALLATION AND OPERATION OF THE NEW AND EXISTING EQUIPMENT AS SHOWN ON THE DRAWINGS SPECIFIED HEREIN, OR AS REQUIRED. SUCH WORK SHALL BE NEATLY AND PROPERLY DONE.

B. BASIC METHOD AND MATERIALS:

1. ALL WIRING SHALL BE INSTALLED IN A CONTINUOUS METALLIC RACEWAY. WIRING SHALL BE RUN CONCEALED IN FINISHED ROOMS. IN UNFINISHED ROOMS WIRING MAY BE RUN EXPOSED IN RACEWAY.

C. RACEWAYS AND FITTINGS:

1. ELECTRICAL METALLIC TUBING (EMT); PROVIDE ELECTRICAL METALLIC TUBING CONFORMING TO FS WW-C-563, ANSI C80.3 AND UL 797. FITTINGS SHALL BE STEEL AND OF THE SCREW OR COMPRESSION TYPE EXCEPT THAT IN POURED CONCRETE THE SCREW TYPE IS NOT ACCEPTABLE. INDENTER FITTINGS ARE NOT ACCEPTABLE. ALL EMT CONNECTORS SHALL BE OF THE INSULATED THROAT TYPE.
2. RIGID STEEL CONDUIT: PROVIDE RIGID STEEL, ZINC-COATED, THREADED TYPE CONFORMING TO FS WW-C-581, ANSI C80.1 AND UL 6. PROVIDE ZINC COATING FUSED TO INSIDE AND OUTSIDE WALLS. RIGID METAL CONDUITS SHALL HAVE THREADED COUPLINGS WHEN INSTALLED IN CONCRETE OR DIRECT BURIAL IN THE GROUND. OTHER INSTALLATIONS IN DRY LOCATIONS MAY BE THREADLESS RIGID FITTINGS.
3. RIGID NON-METALLIC CONDUIT: SCHEDULE 40, 90C, UL-RATED, CONSTRUCT OF POLYVINYL CHLORIDE AND CONFORMING TO NEMA TC-2, FOR DIRECT BURIAL, OR NORMAL ABOVE GROUND USE, UL-LISTED AND IN CONFORMITY WITH NEC ARTICLE 457.
4. ALL CONDUIT SHALL BE 3/4" MINIMUM TRADE SIZE.
5. MINIMUM 3/4" STEEL METAL CLAD CABLE IS ALLOWED WHERE PERMITTED BY THE LOCAL AUTHORITY HAVING JURISDICTION. GROUNDING CONDUCTOR MUST BE PROVIDED IN ALL METAL CLAD CABLE. MC CABLE IS NOT TO BE INBEDDED IN CONCRETE.

D. CONDUIT INSTALLATION:

1. ALL CONDUITS SHALL BE CONCEALED UNLESS NOTED OTHERWISE. INSTALL CONCEALED CONDUITS EITHER IN WALLS, SLABS, OR ABOVE HUNG CEILINGS. IN EXISTING WORK WHERE CONDUITS CANNOT BE CONCEALED IN FINISHED AREAS, SURFACE METAL RACEWAYS SHALL BE USED.
2. PROVIDE RIGID CONDUIT WHERE EMBEDDED IN CONCRETE ON OR BELOW GRADE, IN DIRECT CONTACT WITH EARTH OR FILL BELOW SLAB, WET LOCATIONS, IN SIZES LARGER THAN 2 INCHES, OR INSTALLED OUTDOORS. FOLLOW MINIMUM REQUIREMENTS IN OTHER AREAS AS FOLLOWS:
  - a. USE RIGID STEEL ZINC-COATED CONDUIT IN SPACES WHERE EXPOSED BELOW 4'-0" HEIGHT IN MECHANICAL EQUIPMENT ROOMS, ELECTRICAL EQUIPMENT ROOMS, PENTHOUSES AND IN SERVICE SPLINES.
  - b. USE STEEL ZINC-COATED EMT FOR RACEWAY SYSTEMS EXCEPT AS SPECIFICALLY SPECIFIED PREVIOUSLY, WHERE NOT ALLOWED BY NEC OR NOTED ON DRAWINGS. ADDITIONALLY EMT SHALL NOT BE ACCEPTABLE BELOW GRADE, IN OR UNDER SLABS ON GRADE, IN WET LOCATIONS OR IN SIZES LARGER THAN 2 INCHES.
  - c. RIGID NON-METALLIC CONDUITS MAY BE USED BELOW GRADE OR EMBEDDED IN CONCRETE ON OR BELOW GRADE ONLY.
3. THE ELECTRICAL CONTRACTOR SHALL FIRE CAULK ALL PENETRATIONS THROUGH FIRE RATED WALLS AND CEILINGS.

E. CONDUCTORS:

- a. ALL SERVICE ENTRANCE, FEEDER, AND BRANCH CIRCUIT WIRING SHALL BE COPPER TYPE THHN/THWN.
- b. MINIMUM WIRE SIZE SHALL BE #12 UNLESS OTHERWISE NOTED.
- c. ALUMINUM CONDUCTORS THHN/THWN MAY BE USED IN LIEU OF COPPER CONDUCTORS ON SERVICE ENTRANCE AND FEEDER WIRING.
  - a. ALUMINUM CABLING MUST BE SECURED TO TERMINALS USING AL/CU CRIMP CONNECTIONS.

F. WIRING DEVICES:

1. COLOR SHALL BE GREY WITH STAINLESS STEEL COVERS WHITE. VERIFY COLOR WITH OWNER PRIOR TO INSTALLATION.
2. LOCATE WIRING DEVICES TO COMPLY WITH APPLICABLE BUILDING CODES AND ADA.

G. SWITCHES AND PANELBOARDS:

1. DISCONNECT SWITCHES: PROVIDE SURFACE-MOUNTED, SHEET-STEEL ENCLOSED SWITCHES, OF TYPES, SIZES, AND ELECTRICAL CHARACTERISTICS INDICATED; WITH REQUIRED NUMBER OF POLES. EQUIP WITH OPERATING HANDLE WHICH IS INTEGRAL PART OF ENCLOSURE BASE AND IS CAPABLE OF BEING PADLOCKED IN OFF POSITION.
2. ALL EQUIPMENT SHALL BE OF ONE MANUFACTURER AND SHALL HAVE NEMA RATED ENCLOSURES AS REQUIRED BY THE NEC AND TO SUIT THE ATMOSPHERIC CONDITIONS OF THE EQUIPMENT SURROUNDINGS.

H. GROUNDING:

1. ALL CONDUITS SHALL CONTAIN A MINIMUM OF ONE SEPARATE EQUIPMENT GROUNDING CONDUCTOR IDENTIFIED AND SIZED ACCORDING TO NEC.

I. LUMINAIRES:

1. LUMINAIRES SHALL BE AS PER THE LUMINAIRES SCHEDULE.
2. FURNISH AND INSTALL NEW LAMPS IN ALL LUMINAIRES.
3. CLEAN ALL LUMINAIRES AND LAMPS UPON THE CONCLUSION OF THE WORK. LUMINAIRES THAT ARE CRACKED, BROKEN, RUSTED OR OTHERWISE DAMAGED SHALL BE REPLACED BY THE CONTRACTOR. ALL LUMINAIRES SHALL BE INSTALLED FREE OF GAPS, UNEVEN ROW EXTENSIONS, OR LIGHT LEAKS AROUND RECESSED FIXTURE TRIM.

J. OCCUPANCY SENSORS:

1. OCCUPANCY SENSORS SHALL BE PROVIDED AND INSTALLED PER MANUFACTURER'S RECOMMENDATIONS. PROVIDE POWER PACKS, ADDITIONAL SENSORS, ETC. AS REQUIRED FOR A COMPLETE OCCUPANCY SENSOR BASED LIGHTING CONTROL SYSTEM WHERE INDICATED ON THE DRAWINGS. IT SHALL BE THE CONTRACTOR'S RESPONSIBILITY TO MAKE ALL PROPER ADJUSTMENTS TO ENSURE OWNER SATISFACTION WITH THE OCCUPANCY SENSOR SYSTEM.
2. WALL MOUNTED OCCUPANCY SENSOR SWITCHES SHALL BE PROVIDED WITH MANUAL ON/OFF CONTROL. PROVIDE GRAY COLOR SWITCHES AND STAINLESS STEEL COVERPLATES. WALL MOUNTED OCCUPANCY SENSORS SHALL BE OCCUPANCY CONTROLLED, MOTION ON / AUTOMATIC OFF.

K. SPECIAL ELECTRICAL SYSTEMS:

1. SPECIAL SYSTEMS SHALL INCLUDE SECURITY, COMPUTER, ETC. AS INDICATED ON THE DRAWINGS.
2. UNLESS NOTED OTHERWISE ON THE DRAWINGS EACH SYSTEM SHALL INCLUDE OUTLET BOXES WITH STAINLESS STEEL BLANK COVER AND 1 INCH CONDUIT TO ACCESSIBLE CEILING SPACE. WHERE ACCESSIBLE CEILING SPACE IS NOT AVAILABLE, THE CONDUIT RUNS SHALL EXTEND BACK TO A COMMON LOCATION AS INDICATED ON THE DRAWINGS.
3. CEILING MOUNTED DEVICES SHALL INCLUDE MINIMUM 15' COIL OF CABLING SECURED ABOVE CEILING NEATLY TO STRUCTURE ABOVE.
4. PROVIDE CAT 6 CABLE AND JACKS AT ALL LOW COMPUTER LOCATIONS INDICATED AND CAT 6E CABLE AND JACKS AT ALL HIGH TV DATA LOCATIONS.

M. IDENTIFICATION

1. EQUIPMENT IDENTIFICATION LABELS: ON EACH UNIT OF EQUIPMENT, INSTALL UNIQUE DESIGNATION LABEL THAT IS CONSISTENT WITH WIRING DIAGRAMS, SCHEDULES, AND THE OPERATION AND MAINTENANCE MANUAL. APPLY LABELS TO DISCONNECT SWITCHES AND PROTECTION EQUIPMENT, CENTRAL OR MASTER UNITS, CONTROL PANELS, CONTROL STATIONS, TERMINAL CABINETS, AND RACKS OF EACH SYSTEM. SYSTEMS INCLUDE POWER, LIGHTING, CONTROL, COMMUNICATION, SIGNAL, MONITORING, AND ALARM SYSTEMS UNLESS EQUIPMENT IS PROVIDED WITH ITS OWN IDENTIFICATION.
2. EQUIPMENT TO BE LABELED:
  - a. PANELBOARDS: TYPEWRITTEN DIRECTORY OF CIRCUITS IN THE LOCATION PROVIDED BY PANELBOARD MANUFACTURER. PANELBOARD IDENTIFICATION SHALL BE SELF-ADHESIVE, ENGRAVED LAMINATED ACRYLIC OR MELAMINE LABEL AND SHALL ALSO INDICATE DEVICE OR EQUIPMENT WHERE THE POWER ORIGINATES.
  - b. ENCLOSURES AND ELECTRICAL CABINETS.
  - c. ACCESS DOORS AND PANELS FOR CONCEALED ELECTRICAL ITEMS.
  - d. SWITCHBOARDS.
  - e. TRANSFORMERS: LABEL THAT INCLUDES TAG DESIGNATION SHOWN ON DRAWINGS FOR THE TRANSFORMER AND LOCATION OF TRANSFORMER DISCONNECT MEANS.
  - f. EMERGENCY SYSTEM (LIFE SAFETY SYSTEM) BOXES AND ENCLOSURES.
  - g. ENCLOSED SWITCHES.
  - h. ENCLOSED CIRCUIT BREAKERS.
  - i. ENCLOSED CONTROLLERS.
  - j. VARIABLE-SPEED CONTROLLERS.
  - k. POWER TRANSFER EQUIPMENT.
  - l. BATTERY-INVERTER UNITS.
3. FAULT CURRENT DATA CALCULATED PER SHORT-CIRCUIT STUDY SPECIFICATION SECTION SHALL BE APPLIED VIA ADHESIVE LABEL TO ELECTRICAL EQUIPMENT PER NFPA 70, NATIONAL ELECTRICAL CODE (NEC) OR AS NOTED BELOW. ARC FLASH LABELS WITH DATA AS CALCULATED IN ACCORDANCE WITH ARC-FLASH STUDY SPECIFICATION SECTION SHALL BE APPLIED PER SAID SECTION. PROVIDE ENGRAVED NAMEPLATES FOR EQUIPMENT STATING THE NAME OF EQUIPMENT, VOLTAGE, AND POWER SOURCE. THE EQUIPMENT TO BE LABELED WITH FAULT CURRENT DATA, ARC FLASH DATA, AND NAMEPLATE IDENTIFICATION DATA SHALL INCLUDE BUT NOT BE LIMITED TO:
  - a. SERVICE EQUIPMENT. SERVICE EQUIPMENT RATED 1200 AMPS OR HIGHER SHALL ALSO INCLUDE THE CLEARING TIME OF OVERCURRENT PROTECTIVE DEVICES BASED ON THE AVAILABLE FAULT CURRENT AT THE SERVICE EQUIPMENT AND THE DATE THE LABEL WAS APPLIED.
  - b. SWITCHBOARDS
  - c. TRANSFER SWITCHES
  - d. PANELBOARDS
  - e. DISCONNECT SWITCHES AND ENCLOSED CIRCUIT BREAKERS
  - f. MOTOR CONTROLLERS
  - g. CONTROL PANELS OF MULTI-MOTOR AND COMBINATION LOAD EQUIPMENT OF AIR CONDITIONING AND REFRIGERATION EQUIPMENT.
  - h. ELEVATOR CONTROL PANEL
  - i. INDUSTRIAL CONTROL PANELS
4. THE FOLLOWING EQUIPMENT SHALL BE PERMANENTLY LABELED BY THE MANUFACTURER ON THE EXTERIOR OF THE CONTROL PANEL WITH THE EQUIPMENT'S SHORT CIRCUIT CURRENT RATING (SCCR):
  - a. HERMETIC REFRIGERANT MOTOR COMPRESSORS AND EQUIPMENT. NEC ARTICLE 440.4(B).
  - b. INDUSTRIAL CONTROL PANELS. NEC ARTICLE 409.110(4).
  - c. MOTOR CONTROLLERS. NEC ARTICLE 430.8.
  - d. ELEVATOR CONTROL PANEL. NEC ARTICLE 620.16(A).

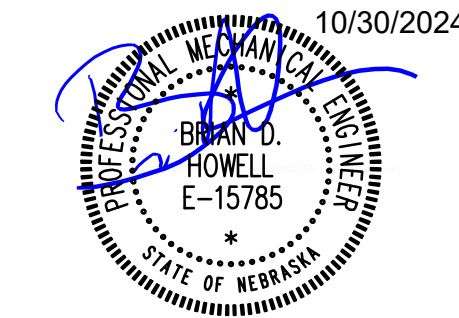

ELECTRICAL SPECS		Date
REVISIONS	Description	
	No.	

**Contractor Storage Bays**  
 McGregor Interests  
 PIN 1729720452, Bennington, NE 68007

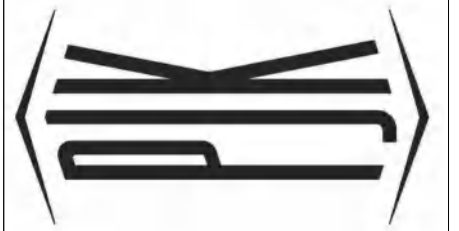

**Paul J. Kelly**  
**Architecture**  
 440 North 61st Street  
 Omaha, Nebraska 68132  
 (402) 320 - 4131  
 pjarchitecture.com

E0.1

Project No. 24-021-01  
 Date 7 October 2024



BDH Engineering  
 440 Regency Parkway,  
 Suite 135  
 Omaha, NE 68114  
 bdhengineer.com  
 CA-4258

COPYRIGHT BDH#: 24030

This document and the information contained may not be reproduced or excerpted from without the express written permission of BDH Engineering, LLC. Unauthorized copying, disclosure or construction use are prohibited by the copyright law.



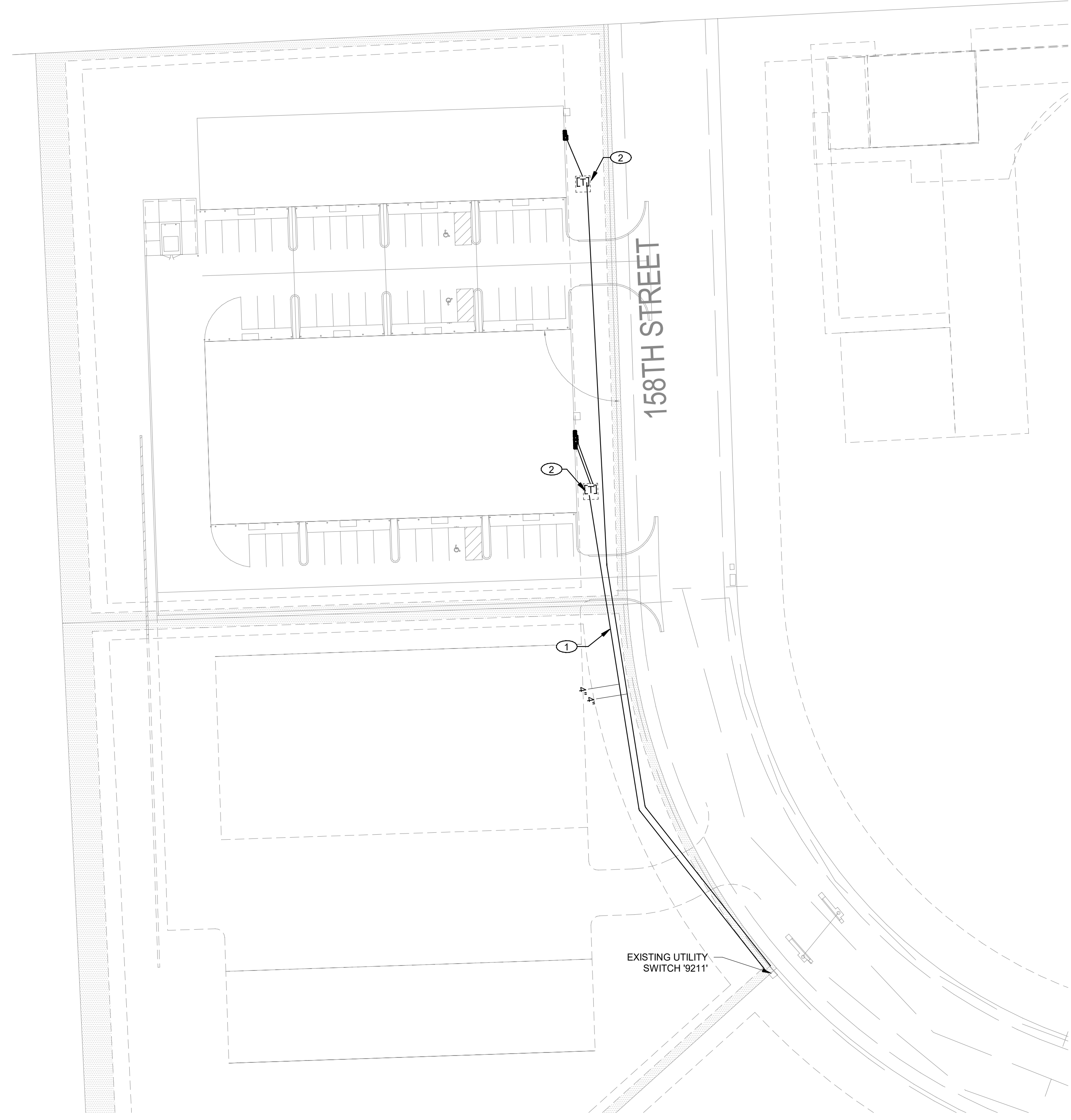

① SITE ELECTRICAL  
1" = 40'-0"

KEYNOTES	
1	COORDINATE ROUTING OF PRIMARY CONDUIT WITH EXISTING UNDERGROUND UTILITIES IN THE AREA. REFER TO CIVIL UTILITY PLAN FOR LOCATIONS.
2	COORDINATE TRANSFORMER LOCATION WITH UTILITY.

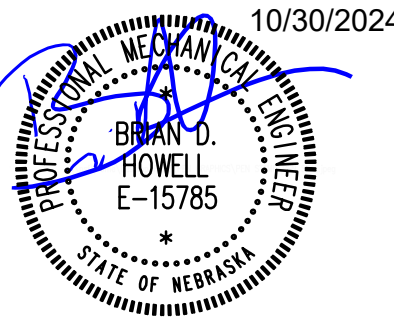

ELECTRICAL SITE PLAN		
REVISIONS		
No.	Description	Date

**Contractor Storage Bays**  
 McGregor Interests  
 PIN 1729720452, Bennington, NE 68007

**PJK**  
 Paul J. Kelly  
 Architecture  
 440 North 61st Street  
 Omaha, Nebraska 68132  
 (402) 320-4131  
 pjkararchitecture.com

**BDH**  
 ENGINEERING  
 BDH Engineering  
 440 Regency Parkway,  
 Suite 135  
 Omaha, NE 68114  
 bdhengineer.com  
 CA-4258

COPYRIGHT BDH#: 24030  
 This document and the information contained may not be reproduced or excerpted from without the express written permission of BDH Engineering, LLC. Unauthorized copying, disclosure or construction use are prohibited by the copyright law.

**E0.2**

Project No. 24-021-01  
 Date 7 October 2024

Print on 22" x 34" format for proper scale

10/15/2024 1:13:57 PM







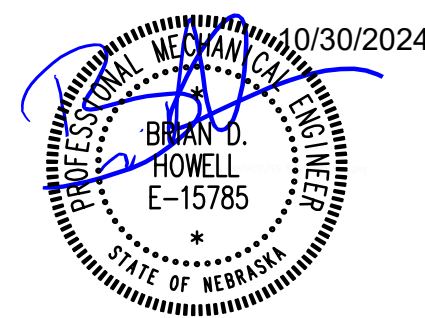

10/15/2024 11:40:00 PM

**ELECTRICAL POWER NOTES:**

- A. SEE SHEET E0.0 FOR ELECTRICAL SYMBOLS LEGEND AND GENERAL ELECTRICAL NOTES.
- B. SEE MECHANICAL AND ELECTRICAL SCHEDULE ON M7.1 FOR ADDITIONAL INFORMATION ON MECHANICAL EQUIPMENT REQUIRING POWER.

**ELECTRICAL LIGHTING NOTES:**

- A. SEE SHEET E0.0 FOR ELECTRICAL SYMBOLS LEGEND AND GENERAL ELECTRICAL NOTES.
- B. SEE LIGHT FIXTURE SCHEDULE ON E7.1 FOR ADDITIONAL INFORMATION.

KEYNOTES	
1	OWNER TO PROVIDE ELECTRIC DOOR STRIKE AND CARD READER FOR FRONT DOORS. PROVIDE POWER TO DOOR ACCESS CONTROL POWER MODULE. COORDINATE WITH CARD READER VENDOR FOR POWER CONNECTION LOCATION.
2	PROVIDE HEXAGON GARAGE GRID LIGHT IN EACH BAY. EACH GRID SIZE TO BE 16" X 38". GRID TO BE DIMMABLE 100/60/30% AND INSTALLED AS HIGH AS POSSIBLE WITHIN THE SPACE. BUDGET PRICE FOR FIXTURE IS \$2,000. CONSULT WITH OWNER ON EXACT MODEL NUMBER AND SPECIFICATIONS. COORDINATE WITH SUPPLIER ON LIGHTING INSTALLATION DETAILS. REFER TO BAY B-601 FOR APPROXIMATE LIGHTING LAYOUT.
3	INSTALL EMERGENCY EGRESS WALL PACK ABOVE EXTERIOR MAIN DOOR. MOUNT BATTERY BACK ON INSIDE FACE OF EXTERIOR WALL.
4	INSTALL WALL PACK ABOVE GARAGE DOOR AT 15'-0" A.F.F.
5	CONNECT RESTROOM EXHAUST FAN TO LIGHTING CIRCUIT. CONTROL WITH LIGHT SWITCH IN ROOM.
6	INSTALL JUNCTION BOX AND CONDUIT ABOVE DOOR FOR SIGNAGE.

BUILDING B ELECTRICAL REVISIONS	
No.	Description

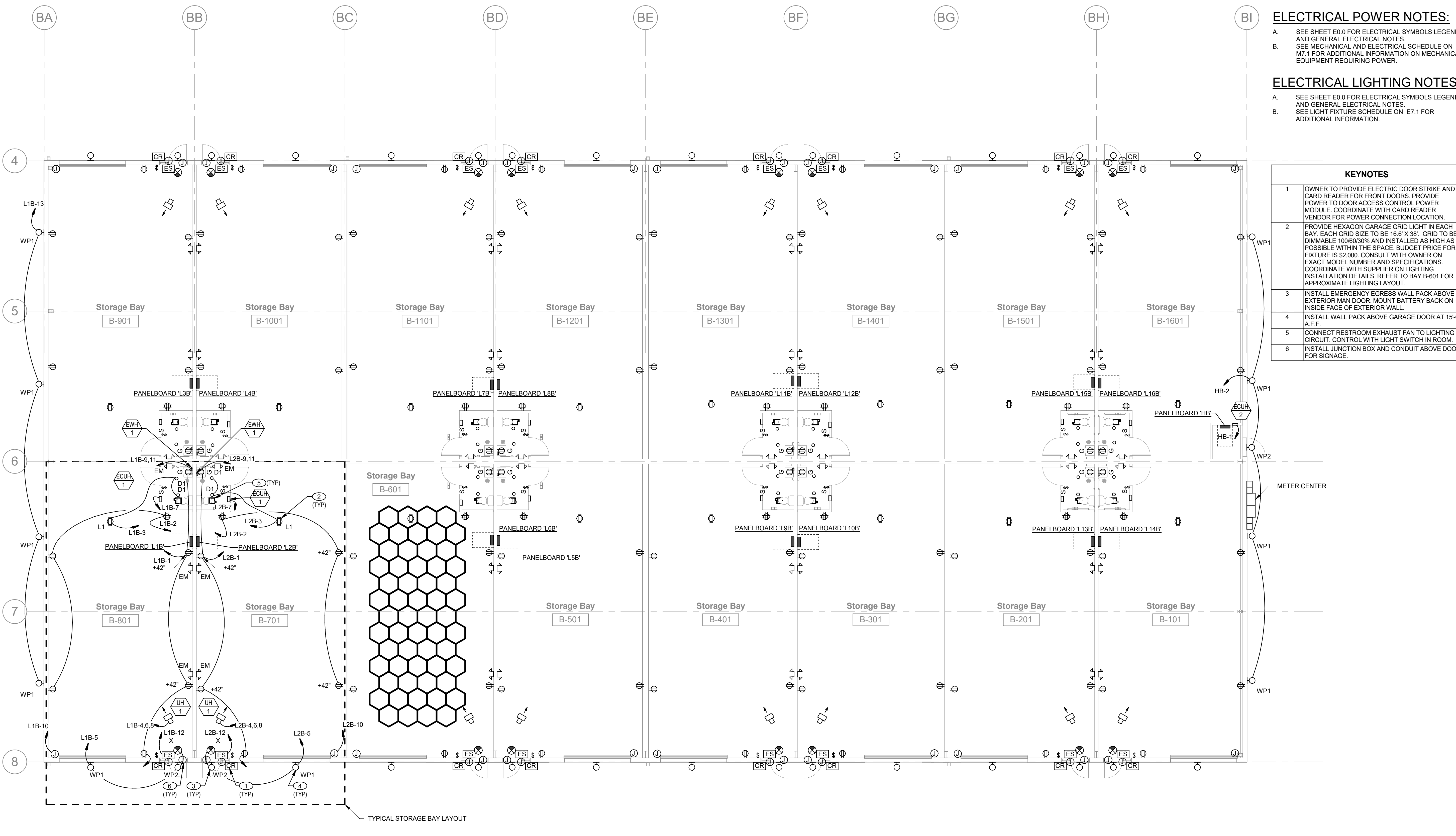

1 BUILDING B ELECTRICAL PLAN  
1/8" = 1'-0"

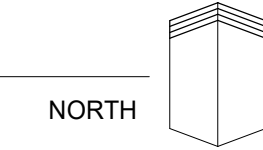

**Contractor Storage Bays**  
 McGregor Interests  
 PIN 1729720452, Bennington, NE 68007



**Paul J. Kelly  
 Architecture**  
 440 North 61st Street  
 Omaha, Nebraska 68132  
 (402) 320 - 4131  
 pjkaarchitecture.com



**BDH  
 ENGINEERING**  
 BDH Engineering  
 440 Regency Parkway,  
 Suite 135  
 Omaha, NE 68114  
 bdhengineer.com  
 CA-4258

COPYRIGHT BDH# 24030

This document and the information contained may not be reproduced or excerpted from without the express written permission of BDH Engineering, LLC. Unauthorized copying, disclosure or construction use are prohibited by the copyright law.

**EI.IB**  
 Project No. 24-021-01  
 Date 7 October 2024

Print on 22" x 34" format for proper scale



**ELECTRICAL NOTES:**

A. SEE SHEET E0.0 FOR ELECTRICAL SYMBOLS LEGEND AND GENERAL ELECTRICAL NOTES.

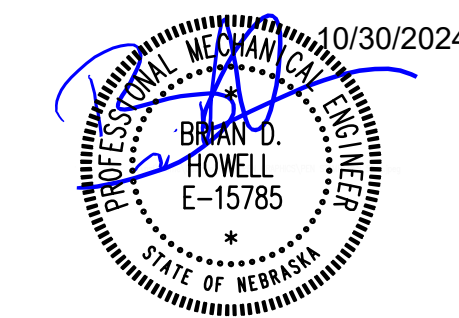

10/15/2024 1:14:00 PM

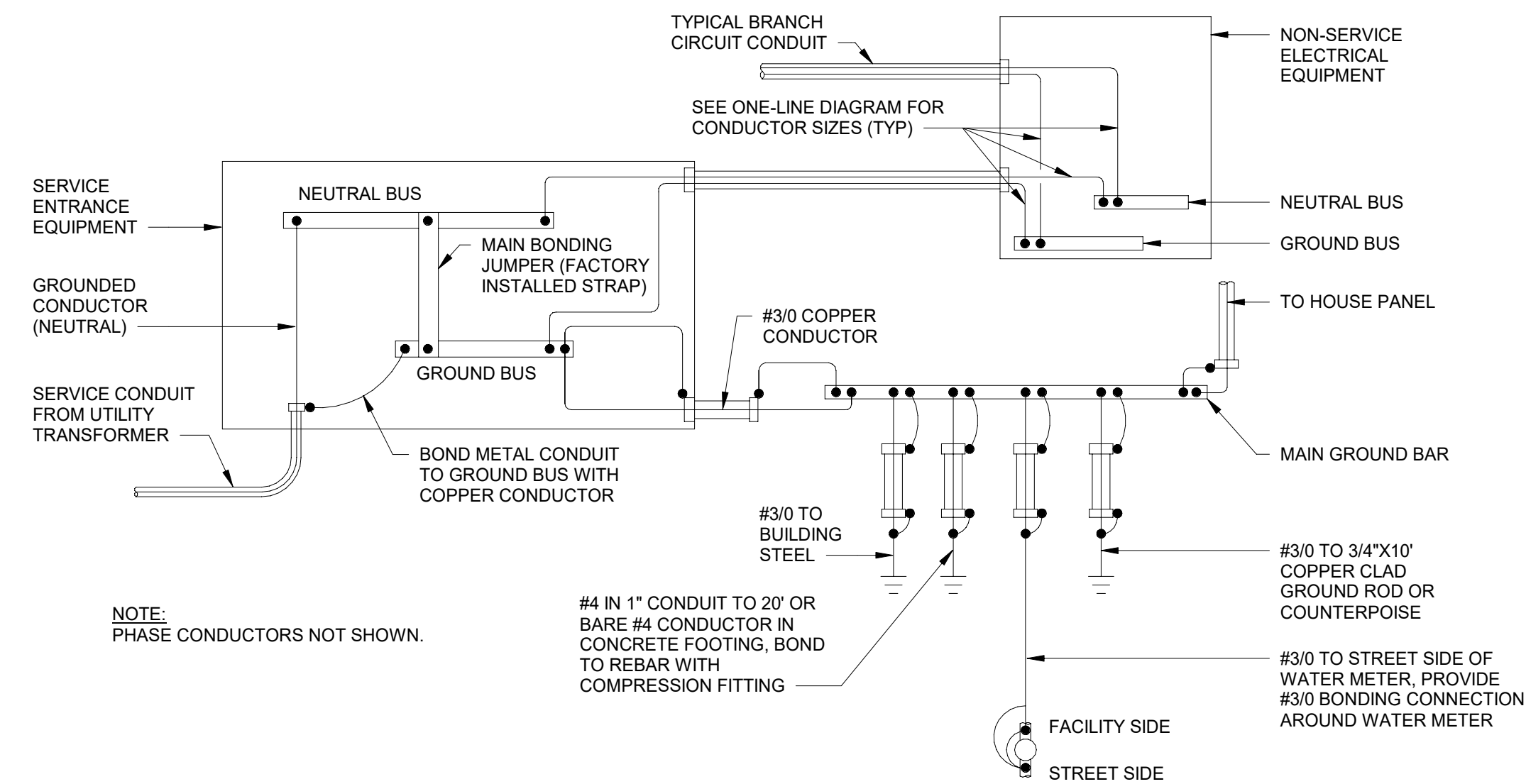

**3 SERVICE ENTRANCE GROUNDING DIAGRAM**  
E6.1 NOT TO SCALE

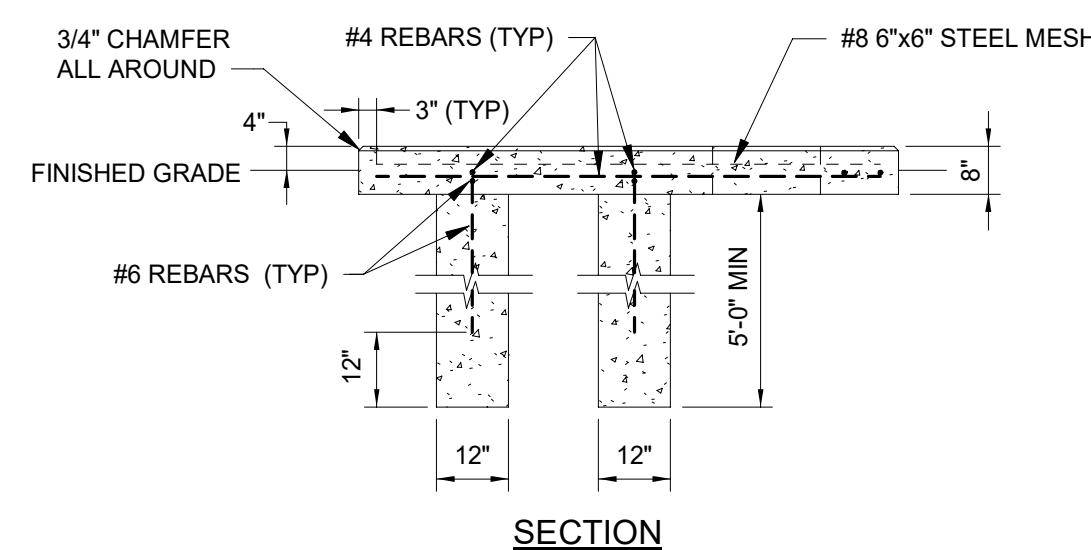
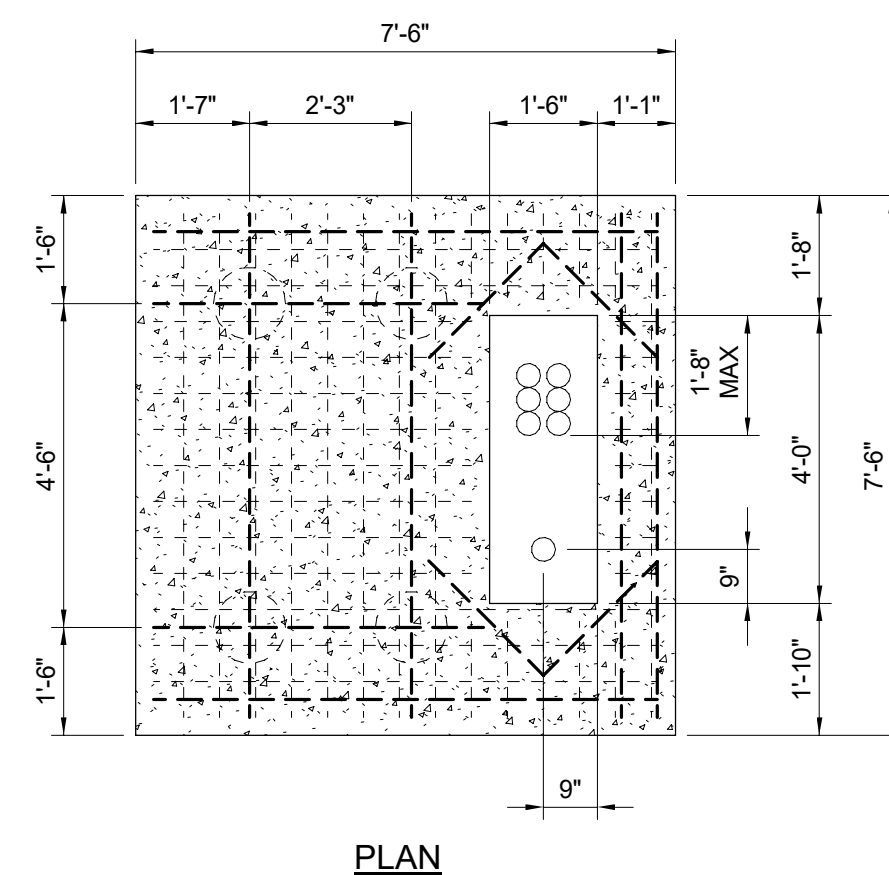

**4 TRANSFORMER SLAB DETAIL**  
E6.1 NOT TO SCALE

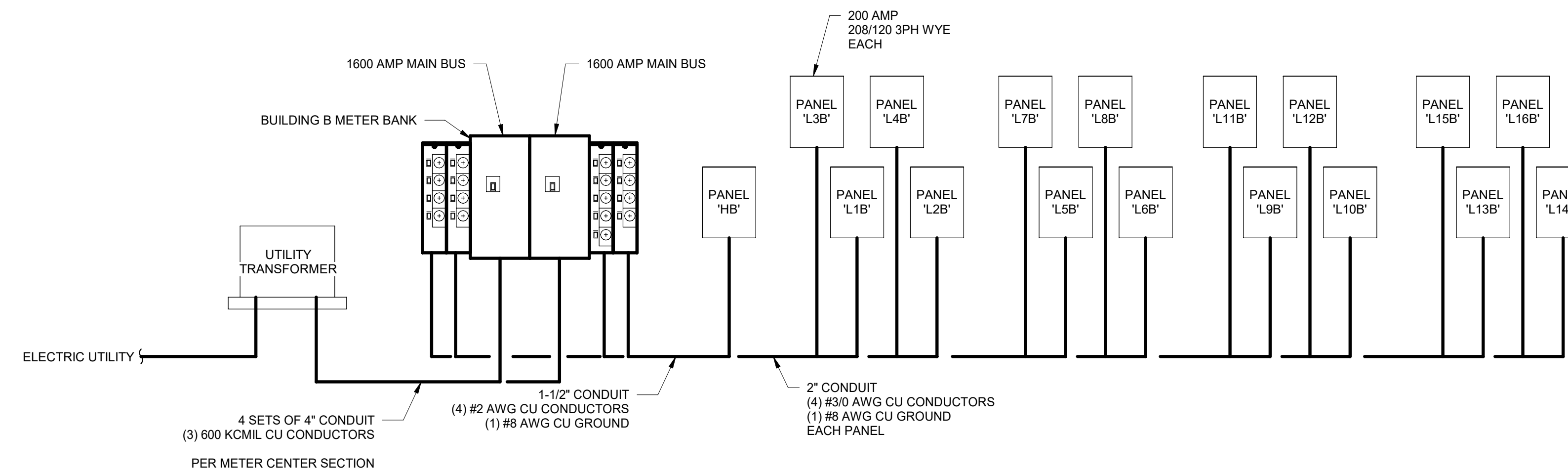

**2 BUILDING B - ONE-LINE POWER RISER DIAGRAM**  
E6.1 NOT TO SCALE

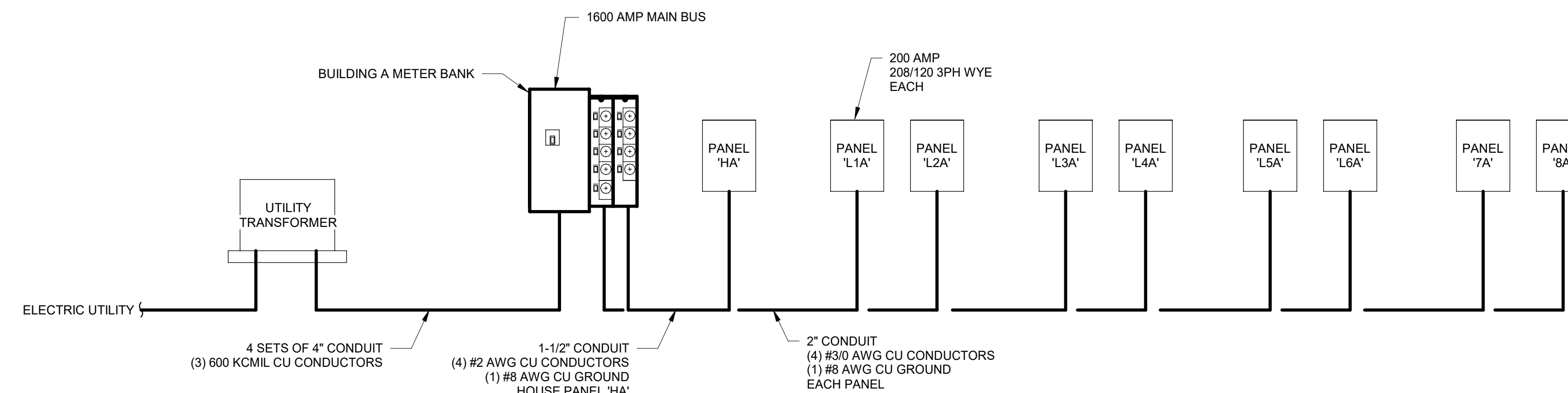

**1 BUILDING A - ONE-LINE POWER RISER DIAGRAM**  
E6.1 NOT TO SCALE

**ELECTRICAL DETAILS AND DIAGRAMS**

No.	Description	Date

**Contractor Storage Bays**  
McGregor Interests  
PIN 1729720452, Bennington, NE 68007



**Paul J. Kelly Architecture**  
440 North 61st Street  
Omaha, Nebraska 68132  
(402) 320-4131  
pjkararchitecture.com



BDH Engineering  
440 Regency Parkway,  
Suite 135  
Omaha, NE 68114  
bdhengineer.com  
CA-4258

COPYRIGHT BDH#: 24030

This document and the information contained may not be reproduced or excerpted from without the express written permission of BDH Engineering, LLC. Unauthorized copying, disclosure or construction use are prohibited by the copyright law.

**E6.1**

Project No. 24-021-01  
Date 7 October 2024

Print on 22" x 34" format for proper scale



LUMINAIRE SCHEDULE										
MARK	DESCRIPTION	MANUFACTURER/SERIES	CATALOG NO.	LIGHT SOURCE		FINISH	MOUNTING	INPUT WATTS	VOLTS	REMARKS
				QTY	TYPE					
D1	6" LED DOWNLIGHT	HALO	HC615D010-HM60525840		LED 4000K 1500LM	WHITE	RECESSED	13 VA	120	
L1	LED HEXAGON LIGHT SYSTEM	HEXAGON GARAGE	16.6" X 38"		LED 4000K 186.050LM	WHITE	SUSPENDED	1700 VA	120	2
EM	EMERGENCY EGRESS LIGHTING	SURE-LITE	SELHP100R3		LED	WHITE	WALL MOUNTED	3 VA	120	1
X	LED EXIT LIGHT	SURE-LITE	APXH7RG		LED RED	WHITE	WALL MOUNTED	3 VA	120	1
WP1	LED WALL PACK	HALO	WXP80LSFSUNVDBZ		LED 5000K 6460LM	BRONZE	WALL MOUNTED	50 VA	120	4,5
WP2	LED EGRESS WALL PACK	LUMARK	AXCS2A-PC1		LED 5000K 2500LM	BRONZE	WALL MOUNTED	21 VA	120	1,3,5

**LUMINAIRE SCHEDULE REQUIREMENTS**

- SUBMIT SHOP DRAWINGS FOR EACH LUMINAIRE, BALLAST/DRIVER, AND LAMP TYPE USED ON PROJECT.
- ACCEPTABLE MANUFACTURERS LISTED ARE CAPABLE OF PROVIDING EQUIVALENT LUMINAIRES. SUBMIT PRODUCT AND ACCESSORIES EQUIVALENT OR SUPERIOR TO THE SPECIFIED LUMINAIRE IN PHOTOMETRIC PERFORMANCE, CONSTRUCTION QUALITY, INCLUDED ACCESSORIES, AND AESTHETICS. ADDITIONAL MANUFACTURERS NOT LISTED MAY ALSO BE SUBMITTED FOR APPROVAL PRIOR TO BID. APPROVAL WILL BE BASED ON AN ASSESSMENT OF THE PRODUCT'S QUALITY, PHOTOMETRIC PERFORMANCE, INCLUDED ACCESSORIES, AND AESTHETICS.
- ALL LUMINAIRES SHALL HAVE A U.L. LABEL. ALL LUMINAIRES USED IN EXTERIOR APPLICATIONS SHALL HAVE A U.L. WET LABEL.
- VERIFY MOUNTING COMPATIBILITY OF LUMINAIRES WITH CEILING SYSTEMS/MATERIALS PRIOR TO ORDERING LUMINAIRES. NOTIFY ENGINEER OF ANY CONFLICTS WITH THE PROPOSED INSTALLATION.
- FOR ALL SUSPENDED LUMINAIRES PROVIDE MOUNTING TYPE INDICATED IN LUMINAIRE SCHEDULE. REFER TO PLANS FOR SUSPENSION LENGTH(S) REQUIRED.

**LUMINAIRE SCHEDULE REMARKS**

- PROVIDE BATTERY BACKUP FOR WALL PACK LIGHT FOR MINIMUM 90 MINUTE RUNTIME.
- SUSPEND LIGHTING AS HIGH AS POSSIBLE FROM STRUCTURE ABOVE.
- MOUNT LIGHT ABOVE EXTERIOR DOOR.
- MOUNT LIGHT AT 12" A.F.F.
- PROVIDE PHOTOMETRIC CONTROL INTEGRAL TO LIGHT.

PANEL HA												
MAINS: 100 A - MCB VOLTAGE: 208/120 Single PHASE: 1 WIRES: 3 MOUNTING: Surface										AIC RATING:		
CCT	AMPS	P	DESCRIPTION	REM	A	B	REM	DESCRIPTION	P	AMPS	CCT	
1	20 A	1	HVAC		1000 VA	121 VA		LIGHTING	1	20 A	2	
3											4	
5											6	
7											8	
9											10	
11											12	
13											14	
15											16	
17											18	
19											20	
21											22	
23											24	
25											26	
27											28	
29											30	
Load Classification				Connected Load	Demand Factor	Estimated Demand	Panel Totals					
Lighting				121 VA	100.00%	121 VA	<b>Total Conn. Load:</b> 1121 VA <b>Total Est. Demand:</b> 1121 VA <b>Total Conn. Current:</b> 5 A <b>Total Est. Demand...</b> 5 A					
HVAC				1000 VA	100.00%	1000 VA						
REMARKS:												

PANEL HB												
MAINS: 100 A - MCB VOLTAGE: 208/120 Single PHASE: 1 WIRES: 3 MOUNTING: Surface										AIC RATING:		
CCT	AMPS	P	DESCRIPTION	REM	A	B	REM	DESCRIPTION	P	AMPS	CCT	
1	20 A	1	ECUH-2		1000 VA	221 VA		LIGHTING	1	20 A	2	
3											4	
5											6	
7											8	
9											10	
11											12	
13											14	
15											16	
17											18	
19											20	
21											22	
23											24	
25											26	
27											28	
29											30	
Load Classification				Connected Load	Demand Factor	Estimated Demand	Panel Totals					
Lighting				221 VA	100.00%	221 VA	<b>Total Conn. Load:</b> 1221 VA <b>Total Est. Demand:</b> 1221 VA <b>Total Conn. Current:</b> 6 A <b>Total Est. Demand...</b> 6 A					
HVAC				1000 VA	100.00%	1000 VA						
REMARKS:												

PANEL L1B												
MAINS: 225 A - MCB VOLTAGE: 208/120 Wye PHASE: 3 WIRES: 4 MOUNTING: Surface										AIC RATING: 10,000		
CCT	AMPS	P	DESCRIPTION	REM	A	B	C	REM	DESCRIPTION	P	AMPS	CCT
1	20 A	1	RECEPTACLE STORAGE...		800 VA	800 VA			RECEPTACLE STORAGE...	1	20 A	2
3	20 A	1	LIGHTING STORAGE BAY...			1726 VA	3333 VA					4
5	20 A	1	LIGHTING				74 VA	3333 VA	UH-1	3	40 A	6
7	20 A	1	ECUH-1		1000 VA	3333 VA						8
9	30 A	2	ECUH-1			2050 VA	200 VA		POWER STORAGE BAY...	1	20 A	10
11	20 A	1	LIGHTING		200 VA		2050 VA	200 VA	POWER	1	20 A	12
13												14
15												16
17												18
19												20
21												22
23												24
25												26
27												28
29												30
31												32
33												34
35												36
37												38
39												40
41												42
Load Classification				Connected Load	Demand Factor	Estimated Demand	Panel Totals					
Lighting				2000 VA	100.00%	2000 VA	<b>Total Conn. Load:</b> 19100 VA <b>Total Est. Demand:</b> 19100 VA <b>Total Conn. Current:</b> 53 A <b>Total Est. Demand...</b> 53 A					
Power				400 VA	100.00%	400 VA						
HVAC				11000 VA	100.00%	11000 VA						
Other				4100 VA	100.00%	4100 VA						
Receptacle				1600 VA	100.00%	1600 VA						
REMARKS:												

ELECTRIC UNIT HEATER SCHEDULE										
MARK	TYPE	ARRANGEMENT	LOCATION	AIRFLOW (CFM)	CAPACITY (KW)	ELECTRICAL DATA		MOUNTING HEIGHT (FT)	MANUFACTURER & MODEL NO.	REMARKS
						V	PH			
ECUH-1	ELECTRIC	RECESSED WALL	RESTROOM	150	1.0	120	1	2'	QMARK	1,2
ECUH-2	ELECTRIC	WATER ROOM	RESTROOM	150	1.0	120	1	2'	QMARK	1,2
UH-1	ELECTRIC	HORIZONTAL SUSPENDED	SHOP	650	10.0	208	3	10'	QMARK MUH-10-8	3,4,5

**REMARKS:**

- PROVIDE RECESSED WALL MOUNTING KIT.
- PROVIDE UNIT WITH INTEGRAL THERMOSTAT AND DISCONNECT.
- PROVIDE CEILING SUSPENSION KIT AND SUSPEND FROM STRUCTURE ABOVE AT 10'-0" A.F.F.
- PROVIDE WITH REMOTE THERMOSTAT AND CONTROL TRANSFORMER
- PROVIDE UNIT WITH INTEGRAL DISCONNECT SWITCH.

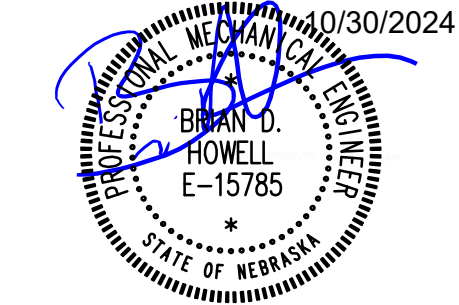

ELECTRICAL SCHEDULES		REVISIONS	
No.	Description	Date	

**Contractor Storage Bays**  
 McGregor Interests  
 PIN 1729720452, Bennington, NE 68007

**Paul J. Kelly**  
 Architecture  
 440 North 61st Street  
 Omaha, Nebraska 68132  
 (402) 320 - 4131  
 pjkararchitecture.com

**E7.1**  
 Project No. 24-021-01  
 Date 7 October 2024

BDH Engineering  
 440 Regency Parkway,  
 Suite 135  
 Omaha, NE 68114  
 bdhengineer.com  
 CA-4258  
 COPYRIGHT BDH# 24030  
 This document and the information contained may not be reproduced or excerpted from without the express written permission of BDH Engineering, LLC. Unauthorized copying, disclosure or construction use are prohibited by the copyright law.